

VANGUARD
VACUUM
LIFTER

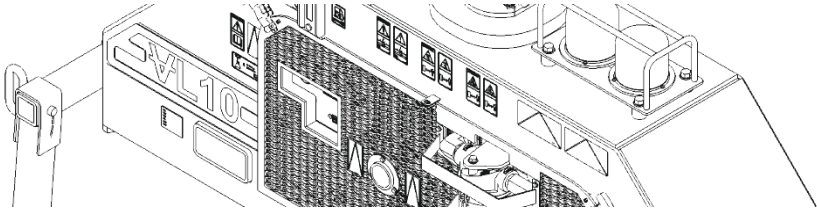

VACUUM LIFTERS
VL10, VL12, VL16

VANGUARD VACUUM LIFTER



VANGUARD VACUUM LIFTERS are self-contained lifting devices powered by a diesel engine and capable of lifting loads up to 16 tonnes (35,275 LB). Easier hook-up to excavators and pads allows you to be ready to work quickly. Large vacuum reservoir combined with efficient pump ensures fast pipe handling. Multiple safety devices will help create an accident-free work environment and protect the load against any damages.



049-05-05-037B

HIGHLIGHTS:

- **ENGINEERED TO LAST** - meets or exceeds ASME B30.20 and ASME BTH-1 specifications
- Pad attachments allow lifting pipes from 4 inch (102 mm) to 48 inch (1219 mm) nominal diameter
- Two-stage filtration system - heavy duty vacuum pre-filter greatly extends life of all vacuum-intake filters and vacuum components, especially in dusty environments
- Neatly organized electrical system with central distribution and dedicated wiring harness for easy troubleshooting and repairs
- Robust Deutsch electrical connectors ensure reliable operation in the most demanding environments
- Wireless remote controller provides safe operation from a distance
- Precise load positioning is achieved by improved hydraulic rotators with high braking capabilities on all Vanguard Vacuum Lifters models
- Visual and audible safety devices quickly warn personnel of insufficient vacuum level
- Dedicated "SAFE TO LIFT" green-beacon signals all personnel when the Vacuum Lifter is ready to lift
- Pads do not damage pipe coating
- Pipes can be stored without the need for spacers
- Possible to lock out Vacuum Lifter against theft or vandalism
- Easy and fast connection between Vacuum Lifter and Pads
- Lifter-mounted Stowing legs and transport tubes aid in handling Vacuum Lifter and Pads, no need for extra frames or worrying about seal damage from the ground
- Larger vacuum-tank provides faster recovery time at high elevations

IMPROVEMENTS AND ADVANTAGES OF VANGUARD LIFTERS:

SAFETY:

- Built to the highest safety standards: meets or exceeds ASME B30.20 and ASME BTH-1 specifications. Designed to Design Category "B" and Service Class "2" with substantially higher number of cycles: between 100,000 and 500,000 for greatly improved safety and reliability over majority of similar units, which are typically Service Class "0" designed for 0 to 20,000 cycles.
- Extensive Vacuum Lifter and Pad Attachment testing, exceeding US required standards ensures safe load holding capability.
- High visibility dual safety beacons, and an audible alarm indicate both safe, and hazardous lifting status.
- Both US and international safety decals designed according to ISO standards identify potential hazards to English and non-English speaking personnel.
- Detailed Operation and Maintenance Manual explaining potential hazards and safe operation. Manual is conveniently stored inside Vacuum Lifter in a sealed tube. Electronic version is also easily downloaded from our website.
- Large, intuitive Operators Panel with complete lockout function for safe storage and prevents unauthorised start-up during maintenance.
- Locking key-start makes it possible to completely lock out Vacuum Lifter against theft or vandalism.
- Integrated foldable pad stand legs and forklift sockets allow for easy storage and moving pad attachments without destroying the seal. Pads are stored seal-down to extend seal life due to minimizing UV exposure. See "Storage" on page 5.

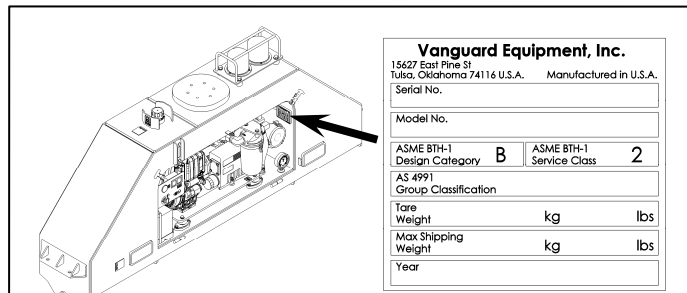

Vanguard Equipment, Inc.		
15627 East Pine St Tulsa, Oklahoma 74116 U.S.A. Manufactured in U.S.A.		
Serial No.		
Model No.		
ASME BTH-1 Design Category	B	ASME BTH-1 Service Class
AS 4991 Group Classification	2	
Tare Weight	kg	lbs
Max Shipping Weight	kg	lbs
Year		



Vacuum lifter and pad attachments extensive testing. 049-55-55-041A



Dual safety beacons, green and amber, enhance safety. 049-55-63-023A



Placement of Seal Insertion Tool and Operation and Maintenance Manual. 049-08-08-002A



Operator control panel with doors closed. Lockout is accessible only with doors open for improved safety. 049-50-63-022B

LOAD HANDLING:

- Larger vacuum-tank than most competitors provides faster recovery time when repetitively handling large loads or when working at high elevation.
- Precise load positioning is achieved by improved, proprietary hydraulic rotator with high braking capabilities on all Vanguard Vacuum Lifters models, addition of precise flow controllers allow fine-tuning rotation speed.



Large tank preserves vacuum level better when working repetitively and at high altitudes. 049-05-05-032B



Proprietary hydraulic rotator with high braking capabilities and clean hydraulic connection. 049-42-60-003A



Positioning is very easy even with long and heavy pipes. 049-05-05-033A

FILTRATION:

- Two-stage air filtration system: heavy duty vacuum pre-filter significantly extends life of all vacuum-intake filters by removing most of the dust-particles, especially in dusty environment. Final intake-filters stop the very small particles to protect all critical vacuum components. This results in longer life of components and much less down-time.
- Oversized diesel fuel-filter, external engine oil filter and heavy duty engine air cleaner help engine run longer without problems.



Large air pre-filter.
049-55-035A

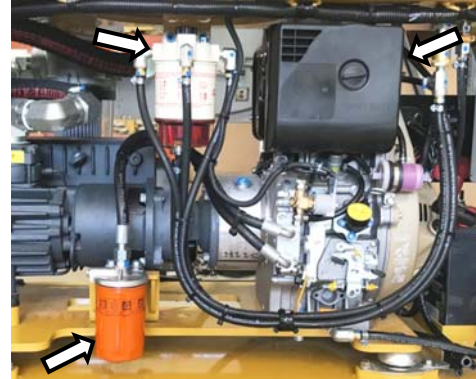

Oversized diesel fuel filter, external oil filter and heavy duty air cleaner. 049-50-50-021A



Dusty conditions are not an issue for Vanguard Vacuum Lifters. 049-05-05-034B

ELECTRICAL:

- Clean and neatly organized electrical system with central distribution and dedicated wiring harness with Deutsch connectors for better resistance to vibration, moisture and dust. Simplified design makes for easy troubleshooting, repairs and improved reliability. All components, together with spare fuses, are locked in a safe polycarbonate enclosure.

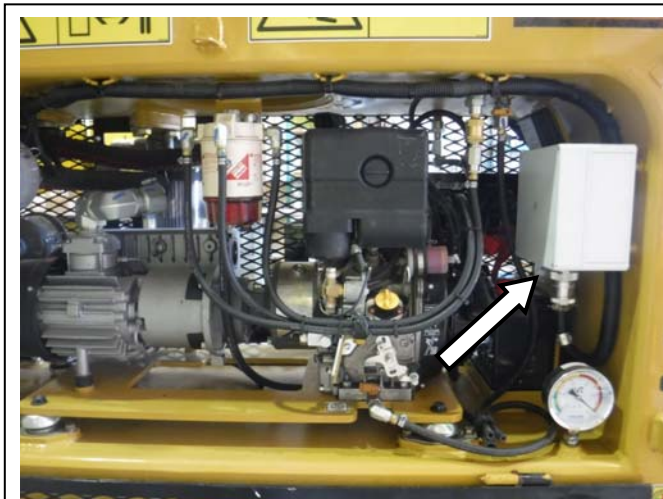

Electrical enclosure is easily accessible for diagnostic and troubleshooting. 049-50-63-003A

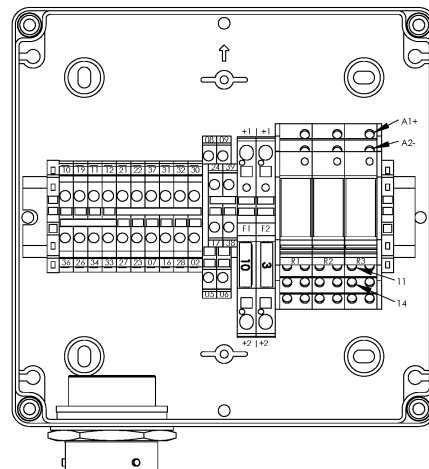

Schematic: inside view of electrical enclosure.
049-40-40-001A

STORAGE:

- Integrated, foldable tank stand legs allow stowing the unit with pads attached, without the need of carrying an additional large and heavy support frame. Simple operation requires pulling out pins and flipping legs up out of the way.
- Integrated foldable pad stand legs and forklift sockets assist with pad storage and manipulation, reducing the risk of damaging the seal.
- Storage for Operation and Maintenance Manual and Seal Insertion Tool is inside safety doors, meaning it is always available on the job site, see page 2.



Tank stand legs in parked position for overnight storage.



Tank stand legs folded up for working. 049-05-05-035B

049-05-05-009B



Pads stored on stand legs with seal in the shadow. 049-05-05-036A

ENVIRONMENTAL:

- Eco oil drain hoses for all components, and diesel fuel tank drain speed up maintenance and keep machine and environment clean.

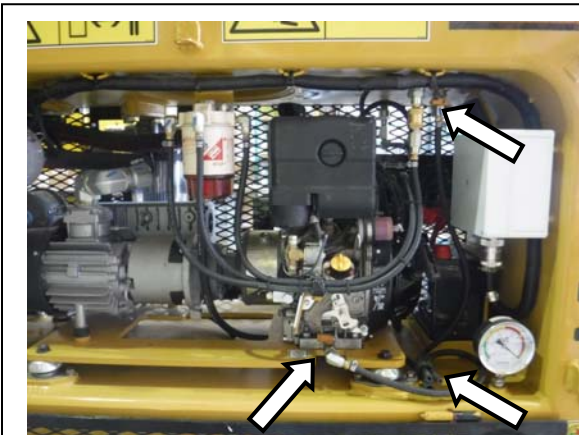

Drain hoses are bundled together. 049-50-50-014A

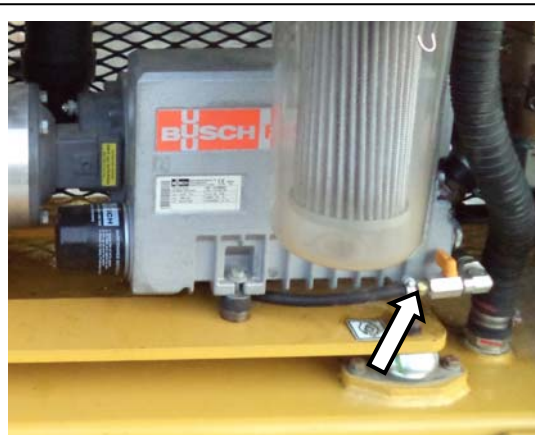

Drain hoses are operated by hand valve. 049-42-55-001B

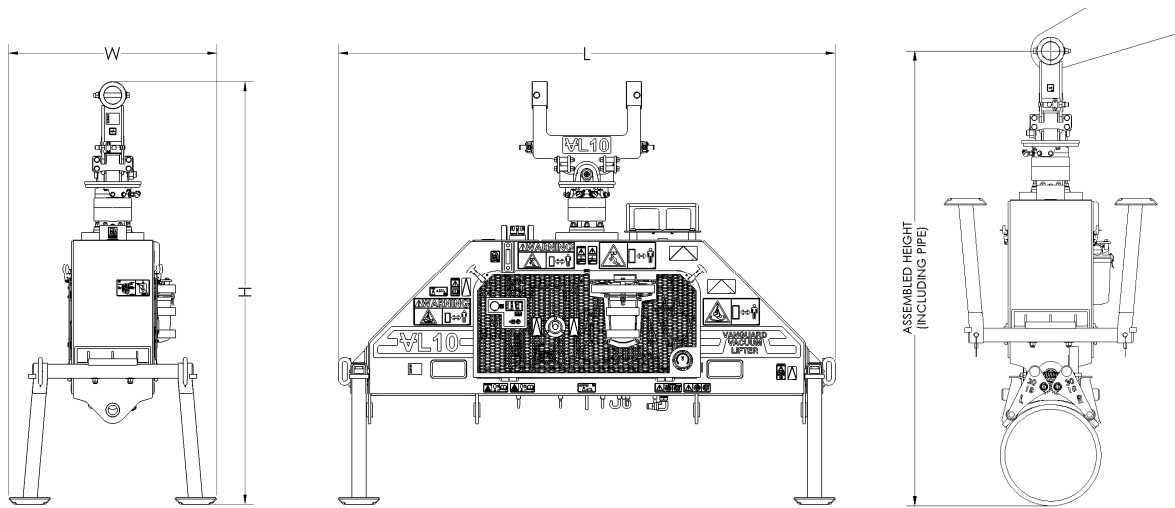

Assembled height dimensions shown on the next page

Model	VL10	VL12	VL16
Lifting capacity	10 tonnes 22,000 LB	12 tonnes 26,500 LB	16 tonnes 35,275 LB
Working dimensions (L/W/H)	112/47/94 inch 2.8/1.1/2.4 m	112/47/91 inch 2.8/1.1/2.3 m	112/47/92 inch 2.8/1.1/2.3 m
Operating weight	1365 kg 3010 LB	1375 kg 3025 LB	1395 kg 3070 LB



049-05-05-040B

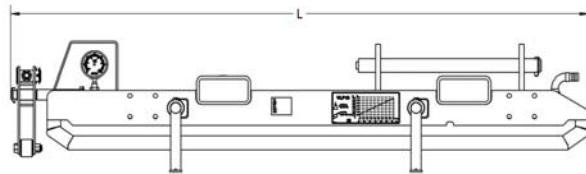
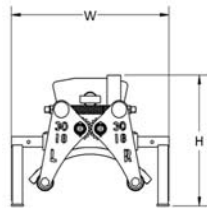

Model	Dimensions (L/W/H) - 2 pads required		Total operating weight for pair		Assembled height (including pipe)	
	inch	meter	LB	kg	inch	meter
VLP4	79.4/16.5/16.4	2.02/0.42/0.42	550	250	85	2.17
VLP6	79.4/16.5/16.4	2.02/0.42/0.42	550	250	87	2.20
VLP8	79.4/16.5/16.4	2.02/0.42/0.42	570	258	89	2.25
VLP10	79.4/16.5/16.4	2.02/0.42/0.42	600	272	91	2.30
VLP12	79.9/18.6/17.3	2.03/0.47/0.44	690	312	92	2.33
VLP14	79.9/18.6/17.3	2.03/0.47/0.44	710	322	93	2.37
VLP16	85.9/18.6/17.2	2.18/0.47/0.44	750	340	95	2.42
VLP18	85.4/23.3/18.7	2.17/0.59/0.47	860	390	97	2.46
VLP20	85.4/23.3/18.6	2.17/0.59/0.47	870	394	99	2.51

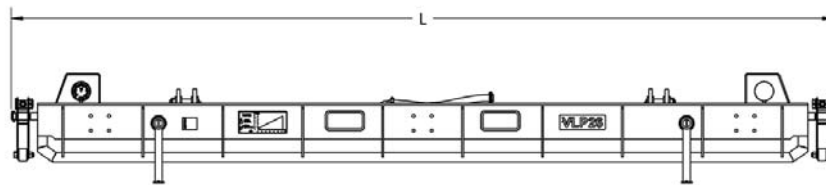
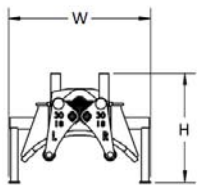

Model	Dimensions (L/W/H) - 1 pad required		Total operating weight		Assembled height (including pipe)	
	inch	meter	LB	kg	inch	meter
VLP22	169.8/29.3/22.5	4.31/0.74/0.57	1085	492	99	2.52
VLP24	169.8/29.3/22.5	4.31/0.74/0.57	1135	525	101	2.58
VLP26	169.8/29.3/22.4	4.31/0.74/0.57	1160	526	103	2.63
VLP28	169.8/35.5/24.8	4.31/0.90/0.63	1215	551	105	2.68
VLP30	169.8/35.5/24.8	4.31/0.90/0.63	1260	572	107	2.73
VLP32	181.5/35.5/24.6	4.61/0.90/0.63	1480	671	109	2.78
VLP34	181.5/35.5/24.5	4.61/0.90/0.62	1490	676	111	2.83
VLP36	181.5/35.5/24.4	4.61/0.90/0.62	1500	680	113	2.88
VLP42	228.5/45.0/25.3	5.80/1.14/0.64	In development		119	3.03
VLP48	228.5/45.0/24.9	5.80/1.14/0.63	in development		125	3.18

PIPE WEIGHT QUICK REFERENCE

Instructions: Refer to Table 1 for pipe weight per foot (lbs/ft) using the pipe size and pipe wall thickness. To calculate pipe weight (W), multiply pipe weight per foot by pipe length in feet (L); $W=(\text{lbs/ft})*(L)$. Check pipe weight against the maximum lifting capacity by vacuum pad size and altitude at working environment in Table 2. Contact Vanguard for special-order Vacuum Pads if the pipe is too heavy for the rated load in Table 2.

Table 1: Pipe Weight per foot by Pipe Size¹

Pipe Size	OD [in]	Wall [in]	Weight [lbs/ft]	Wall [in]	Weight [lbs/ft]	Wall [in]	Weight [lbs/ft]
3	3.5	0.12	4.34	0.216	7.58	0.438	14.34
		0.156	5.58	0.25	8.69	0.6	18.6
		0.172	6.12	0.281	9.67		
		0.188	6.66	0.3	10.26		
3.5	4	0.12	4.98	0.25	10.02	0.318	12.52
		0.226	9.12	0.281	11.17	0.636	22.87
4	4.5	0.12	5.62	0.237	10.8	0.438	19.02
		0.156	7.24	0.25	11.36	0.531	22.53
		0.188	8.67	0.281	12.67	0.674	27.57
		0.203	9.32	0.312	13.97		
		0.219	10.02	0.337	15		
5	5.563	0.188	10.8	0.312	17.51	0.625	32.99
		0.219	12.51	0.344	19.19	0.75	38.59
		0.258	14.63	0.375	20.8		
		0.281	15.87	0.5	27.06		
6	6.625	0.109	7.59	0.28	18.99	0.625	40.09
		0.134	9.3	0.312	21.06	0.719	45.39
		0.156	10.79	0.344	23.1	0.864	53.21
		0.188	12.94	0.375	25.05	1	60.13
		0.203	13.94	0.432	28.6	1.125	66.14
		0.219	15	0.5	32.74		
		0.25	17.04	0.562	36.43		
8	8.625	0.188	16.96	0.322	28.58	0.594	51
		0.203	18.28	0.344	30.45	0.625	53.45
		0.219	19.68	0.375	33.07	0.719	60.77
		0.237	21.25	0.406	35.67	0.812	67.82
		0.25	22.38	0.438	38.33	0.875	72.49
		0.277	24.72	0.5	43.43	0.906	74.76
		0.312	27.73	0.562	48.44		
10	10.75	0.188	21.23	0.344	38.27	0.625	67.65
		0.203	22.89	0.365	40.52	0.719	77.1
		0.219	24.65	0.375	41.59	0.812	86.26
		0.237	26.64	0.438	48.28	0.844	89.38
		0.25	28.06	0.5	54.79	1	104.23
		0.279	31.23	0.562	62.21	1.125	115.75
		0.307	34.27	0.594	64.49		
12	12.75	0.188	25.25	0.33	43.81	0.625	81.01
		0.203	27.23	0.344	45.62	0.688	88.71
		0.219	29.34	0.375	49.61	0.75	96.21
		0.237	31.7	0.406	53.57	0.844	107.42
		0.25	33.41	0.438	57.65	1	125.61
		0.281	37.46	0.5	65.48	1.125	139.81
		0.312	41.48	0.562	73.22	1.312	160.42

¹ Based on selected manufacturers' data for steel pipe, use for quick reference only. These weights do not include coating, etc. Do not use as a substitute for actual pipe weights, verify actual weights with specific pipe used on the job.

Pipe Size	OD [in]	Wall [in]	Weight [lbs/ft]	Wall [in]	Weight [lbs/ft]	Wall [in]	Weight [lbs/ft]
14	14	0.25	36.75	0.459	66.44	0.812	114.48
		0.281	41.21	0.5	72.16	0.938	130.98
		0.312	45.65	0.562	80.73	1.094	150.93
		0.344	50.22	0.594	85.13	1.25	170.37
		0.375	54.62	0.625	89.36	1.406	189.29
		0.406	59	0.688	97.91		
		0.438	63.5	0.75	106.23		
16	16	0.188	31.78	0.375	62.64	0.688	112.62
		0.203	34.28	0.406	67.68	0.75	122.27
		0.219	36.95	0.438	72.86	0.812	131.84
		0.237	39.94	0.469	77.87	1.031	164.98
		0.25	42.09	0.5	82.85	1.219	192.61
		0.281	47.22	0.562	92.75	1.438	223.85
		0.312	52.32	0.625	102.72	1.594	245.48
		0.344	57.57	0.656	107.6		
18	18	0.219	41.63	0.406	76.36	0.75	138.3
		0.237	45	0.438	82.23	0.812	149.2
		0.25	47.44	0.469	87.89	0.938	171.08
		0.281	53.23	0.5	93.54	1.156	208.15
		0.312	58.99	0.562	104.76	1.275	227.96
		0.344	64.93	0.625	116.09	1.562	274.48
		0.375	70.65	0.688	127.32	1.781	308.79
20	20	0.219	46.31	0.438	91.59	0.812	166.56
		0.239	50.49	0.469	97.92	1.031	209.06
		0.25	52.78	0.5	104.23	1.281	256.34
		0.281	59.23	0.562	116.78	1.5	296.65
		0.312	65.66	0.594	123.23	1.752	341.41
		0.344	72.28	0.625	129.45	1.968	379.36
		0.375	78.67	0.688	142.03		
		0.406	85.04	0.75	154.34		
22	22	0.25	58.13	0.469	107.95	0.875	197.62
		0.281	65.24	0.5	114.92	1.125	251.05
		0.312	72.34	0.562	128.79	1.252	277.27
		0.344	79.64	0.625	142.81	1.625	353.94
		0.375	86.69	0.688	156.74	1.875	403.38
		0.406	93.72	0.75	170.37	2.125	451.49
		0.438	100.96	0.812	183.92		
24	24	0.25	63.47	0.5	125.61	0.969	238.57
		0.281	71.25	0.562	140.81	1.219	296.86
		0.312	79.01	0.625	156.17	1.531	367.74
		0.344	86.99	0.688	171.45	1.812	429.79
		0.375	94.71	0.75	186.41	2.062	483.57
		0.406	102.4	0.812	201.28	2.343	542.44
		0.438	110.32	0.875	216.31		
		0.469	117.98	0.938	231.25		
26	26	0.25	68.82	0.406	111.08	0.625	169.54
		0.281	77.26	0.438	119.69	0.656	177.73
		0.312	85.68	0.469	128	0.688	186.16
		0.344	94.35	0.5	136.3	0.75	202.14
		0.375	102.72	0.562	152.83	0.938	251.3
28	28	0.25	74.16	0.438	129.05	0.625	182.9
		0.281	83.26	0.469	138.03	0.656	191.75
		0.312	92.35	0.5	146.99	0.688	200.87
		0.344	101.7	0.531	155.92	0.719	209.68
		0.375	110.71	0.562	164.84	0.75	218.48
		0.406	119.76	0.594	174.02		

Pipe Size	OD [in]	Wall [in]	Weight [lbs/ft]	Wall [in]	Weight [lbs/ft]	Wall [in]	Weight [lbs/ft]
30	30	0.25	79.51	0.438	138.42	0.688	215.58
		0.281	89.27	0.469	148.06	0.75	234.51
		0.312	99.02	0.5	157.68	0.875	272.43
		0.344	109.06	0.562	176.86	1	310.01
		0.375	118.76	0.625	196.26		
		0.406	128.44	0.656	205.78		
32	32	0.25	84.85	0.438	147.78	0.688	230.29
		0.281	95.28	0.469	158.08	0.75	250.55
		0.312	105.69	0.5	168.37	0.875	291.14
		0.344	116.41	0.562	188.87	1	331.39
		0.375	126.78	0.625	209.62		
		0.406	137.12	0.656	219.8		
34	34	0.25	90.2	0.438	157.14	0.656	233.83
		0.312	112.36	0.469	168.11	0.688	245
		0.344	123.77	0.5	179.06	0.75	266.58
		0.375	134.79	0.562	200.89	0.875	309.84
		0.406	145.8	0.625	222.99	1	352.77
36	36	0.25	95.54	0.438	166.51	0.688	259.71
		0.281	107.3	0.469	178.14	0.75	282.62
		0.312	119.03	0.5	189.75	0.875	328.55
		0.344	131.12	0.562	212.9	1	374.15
		0.375	142.81	0.625	236.35		
		0.406	154.48	0.656	247.85		
38	38	0.312	125.7	0.469	188.17	0.75	298.65
		0.344	138.47	0.5	200.44	0.875	347.26
		0.375	150.83	0.562	224.92	1	395.53
		0.406	163.16	0.625	249.71		
		0.438	175.87	0.688	274.42		
40	40	0.312	132.37	0.469	198.19	0.75	314.69
		0.344	145.83	0.5	211.13	0.875	365.97
		0.375	158.85	0.562	236.93	1	416.91
		0.406	171.81	0.625	263.07		
		0.438	185.21	0.688	289.13		
42	42	0.25	111.58	0.438	194.6	0.688	303.84
		0.312	139.04	0.469	208.22	0.75	330.72
		0.344	153.18	0.5	221.82	0.875	384.67
		0.375	166.86	0.562	248.95	1	438.29
		0.406	180.52	0.625	276.44		
48	48	0.25	127.61	0.406	206.56	0.625	316.52
		0.281	143.34	0.438	222.7	0.688	347.97
		0.312	159.05	0.469	238.3	0.75	378.83
		0.344	175.25	0.5	253.89	0.875	440.8
		0.375	190.92	0.562	285	1	502.43

Table 2: Maximum Lifting Capacity in pounds by Vacuum Pad Size and Altitude at Working Environment

Atmospheric conditions can vary, use for quick reference only. Refer to the Operator and Maintenance manual for procedures to determine actual Load Capacity/WLL based on achievable vacuum level.

Pad size	0 - 5,000 [ft]	6,000 [ft]	7,000 [ft]	8,000 [ft]	9,000 [ft]	10,000 [ft]	11,000 [ft]	12,000 [ft]	13,000 [ft]	14,000 [ft]	15,000 [ft]	16,000 [ft]	17,000 [ft]
4	1,055	1,023	984	947	911	876	842	809	778	747	717	688	660
6	2,147	2,072	1,985	1,901	1,819	1,739	1,663	1,588	1,516	1,446	1,378	1,313	1,250
8	3,063	2,961	2,842	2,727	2,615	2,507	2,403	2,301	2,203	2,107	2,015	1,926	1,840
10	4,466	4,303	4,112	3,928	3,748	3,574	3,407	3,242	3,086	2,932	2,784	2,640	2,503
12	4,990	4,810	4,601	4,399	4,201	4,010	3,827	3,646	3,474	3,305	3,142	2,985	2,834
14	5,770	5,581	5,361	5,149	4,941	4,740	4,548	4,357	4,177	3,998	3,828	3,662	3,504
16	6,764	6,547	6,295	6,051	5,813	5,583	5,362	5,144	4,937	4,733	4,537	4,347	4,165
18	9,135	8,837	8,490	8,154	7,826	7,509	7,205	6,904	6,619	6,338	6,068	5,807	5,557
20	10,163	9,848	9,479	9,123	8,775	8,439	8,116	7,797	7,494	7,196	6,910	6,633	6,368
22	13,629	13,204	12,708	12,229	11,761	11,309	10,875	10,446	10,039	9,638	9,253	8,880	8,523
24	15,528	15,046	14,482	13,938	13,406	12,894	12,400	11,913	11,451	10,995	10,558	10,134	9,729
26	16,260	15,755	15,165	14,595	14,039	13,502	12,985	12,475	11,991	11,514	11,057	10,613	10,189
28	17,563	17,017	16,379	15,762	15,160	14,580	14,020	13,468	12,945	12,429	11,934	11,454	10,995
30	19,524	18,916	18,206	17,520	16,850	16,204	15,581	14,967	14,385	13,810	13,260	12,725	12,214
32	22,327	21,636	20,828	20,048	19,285	18,550	17,843	17,144	16,481	15,828	15,202	14,594	14,013
34	23,196	22,476	21,634	20,820	20,026	19,260	18,522	17,794	17,104	16,423	15,770	15,137	14,531
36	24,150	23,395	22,513	21,662	20,830	20,028	19,255	18,492	17,770	17,056	16,373	15,710	15,076
42	In development												
48	In development												



049-05-05-039A

FREIGHT BREAKDOWN (for air freight)

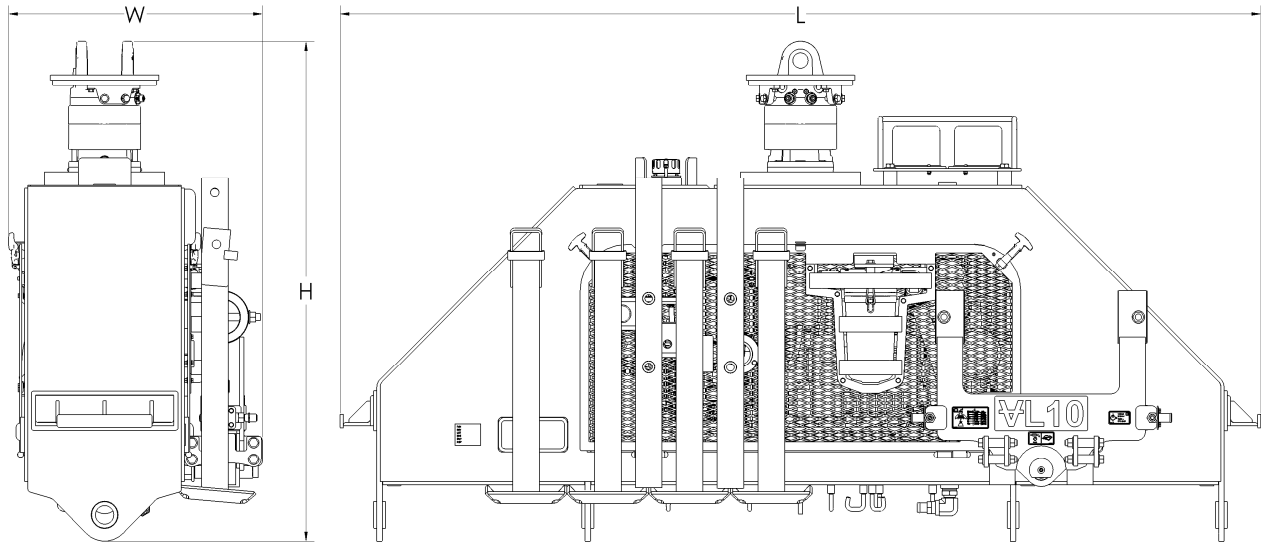

Model	VL10	VL12	VL16
Lifting capacity	10 tonnes 22,000 LB	12 tonnes 26,500 LB	16 tonnes 35,275 LB
Shipping dimensions (L/W/H)	107/29/58 inch 2.7/0.75/1.47 m	107/29/55 inch 2.7/0.75/1.40 m	107/29/56 inch 2.7/0.75/1.42 m
Total shipping weight	1350 kg 2976 LB	1360 kg 3000 LB	1380 kg 3042 LB

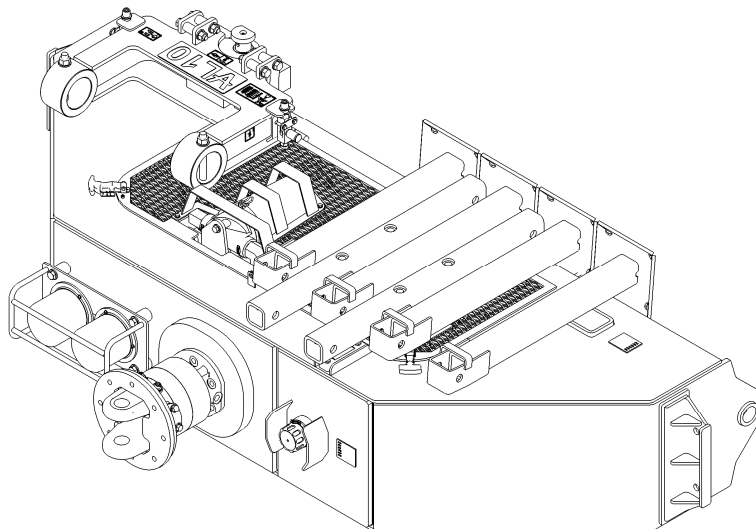

MANUFACTURING: 15627 EAST PINE, TULSA, OK, 74116, USA
 ☎: 918.437.1796 📠: 918.437.1794 🌐: vanguardequip.com

ADMINISTRATION: 107 - 197 FORESTER STREET, NORTH VANCOUVER, BC, V7H 0A6, CANADA
 ☎: 604.985.8751 📠: 604.985.4722