

# Operation and Maintenance Manual

---

**VP 72Gs2 Pipelayer attachment Kit for D7G SERIES II**

---

S/N 041050010021 – UP (Sideboom)

**TO BE USED WITH CATERPILLAR  
D7G SERIES II TRACTOR OPERATION AND MAINTENANCE MANUALS**

---

**VANGUARD EQUIPMENT, INC.  
15627 EAST PINE ST  
TULSA, OKLAHOMA  
74116, USA**

 : 918.437.1796

 : 918.437.1794

# Table of Contents

<b>FOREWORD .....</b>	<b>1</b>
LITERATURE INFORMATION.....	1
MACHINE DESCRIPTION .....	1
SAFETY.....	1
OPERATION .....	1
MAINTENANCE.....	1
MAINTENANCE INTERVALS .....	1
<b>SAFETY SECTION .....</b>	<b>2</b>
SAFETY MESSAGES – VP 72Gs2 PIPELAYER KIT .....	2
<i>Do Not Operate (1)</i> .....	4
<i>Electrical Power Lines (2)</i> .....	4
<i>Tipover Hazard (3)</i> .....	5
<i>Free Fall Active (4)</i> .....	5
<i>Hydraulic Accumulator (5, 6)</i> .....	6
<i>Transportation Hazard (7)</i> .....	7
<i>Counterweight Crushing Hazard (8)</i> .....	7
<i>Boom Stop Operation and Adjustment (9)</i> .....	8
BEFORE OPERATION .....	8
VISIBILITY INFORMATION.....	8
OPERATION .....	9
<i>Machine Operating Temperature Range</i> .....	9
<i>Machine Operation</i> .....	9
<i>Lifting Capacities</i> .....	10
<i>Limitations on Lifting Loads That Exceed the Working Range</i> .....	10
<i>Electrical Power Lines</i> .....	11
<i>Parking</i> .....	11
<i>Slope Operation</i> .....	12
<i>Guards</i> .....	13
<b>PRODUCT INFORMATION SECTION.....</b>	<b>13</b>
GENERAL INFORMATION .....	13
<i>Components</i> .....	13
<i>Specifications</i> .....	14
<i>Intended Use</i> .....	14
<i>Restrictions to Application and Configuration</i> .....	14
LIFTING CAPACITIES .....	15
<b>OPERATION SECTION.....</b>	<b>16</b>
BEFORE OPERATION .....	16
<i>Mounting and Dismounting</i> .....	16
<i>Daily Inspection</i> .....	17
<i>Daily Checks</i> .....	18
TRACTOR OPERATION .....	18
<i>Hydraulic Oil Temperature</i> .....	18
PIPELAYER OPERATION .....	19
<i>Speed/Lockout Control Lever (1)</i> .....	19
<i>Speed/Lockout Control Lock (2)</i> .....	20
<i>Hook Control (3)</i> .....	20
<i>Accumulator - Relieving Charge</i> .....	20
<i>Boom Control (4)</i> .....	21
<i>Boom Stop Valve</i> .....	21
<i>Counterweight Control (5)</i> .....	22
<i>Horn location moved (6)</i> .....	22
<b>TRANSPORTATION INFORMATION.....</b>	<b>23</b>
SHIPPING THE MACHINE .....	23
REMOVAL OF THE BOOM .....	24
COUNTERWEIGHT STOWING MECHANISM .....	27

<i>Transportation Hazard</i> .....	27
<b>MAINTENANCE AND LUBRICATION SECTION</b> .....	<b>28</b>
LUBRICANT VISCOSITIES .....	28
GENERAL.....	28
SELECTING THE VISCOSITY .....	28
<i>Lubricant Viscosities for Ambient Temperatures</i> .....	28
CAPACITIES (REFILL) .....	28
S-O-S INFORMATION.....	28
MAINTENANCE INTERVAL SCHEDULE (MIS).....	29
SERVICE INTERVALS.....	29
WHEN REQUIRED .....	29
<i>Every 10 Service Hours or Daily</i> .....	29
<i>Every 50 Service Hours or Weekly</i> .....	29
<i>200 Hours Service Interval or Monthly</i> .....	30
<i>Every 500 Service Hours</i> .....	30
<i>Every 500 Service Hours or 3 Months</i> .....	30
<i>Every 2000 Service Hours or 1 Year</i> .....	30
ACCUMULATOR CHARGING .....	31
BOOM STOP VALVE OPERATION AND ADJUSTMENT.....	32
BOOM LINE – INSTALL .....	32
BOOM PIVOT PINS – LUBRICATE .....	36
COUNTERWEIGHT CYLINDER BEARINGS – LUBRICATE .....	36
COUNTERWEIGHT HINGE PINS - LUBRICATE .....	37
FAIRLEAD SHEAVE – LUBRICATE .....	38
HOOK AND WIRE CABLE – INSPECT .....	38
<i>Inspect the Hook</i> .....	38
<i>Inspect Wire Cable - Boom and Hook lines</i> .....	38
HOOK LOAD LINE – INSTALL.....	39
HYDRAULIC SYSTEM OIL - CHANGE.....	42
HYDRAULIC SYSTEM OIL FILTER - REPLACE.....	43
HYDRAULIC SYSTEM OIL LEVEL – CHECK .....	44
HYDRAULIC SYSTEM OIL SAMPLING.....	44
OIL FILTER INSPECTION.....	44
SHEAVE BLOCK BEARING – LUBRICATE.....	45
TRACTOR MAINTENANCE.....	45

# Foreword

## Literature Information

This manual should be stored in the operator's compartment in the literature holder or seat back literature storage area.

This manual contains safety information, operation instructions, transportation information, lubrication information and maintenance information.

Some photographs or illustrations in this publication show details or attachments that can be different from your machine. Guards and covers might have been removed for illustrative purposes.

Continuing improvement and advancement of product design might have caused changes to your machine which are not included in this publication. The latest version of this publication is available for download from the internet at [vanguardequip.com](http://vanguardequip.com). Read, study and keep this manual with the machine.

Whenever a question arises regarding your machine, or this publication, please consult Vanguard Equipment for the latest available information.

## Machine Description

The sideboom equipment is attached to a Caterpillar D7G Series II tractor. The primary use of this machine is for petroleum-product pipeline-construction in the 20" to 30" (510 to 765 mm) pipeline range.

The operator should read, understand, and follow both the tractor and the pipelayer operating and maintenance instructions. The operator must comply with all pipelayer procedures, regulations, and safety precautions.

This equipment is to be operated by qualified personnel only.

The daily service/inspection procedure should be performed before start-up.

Operate all pipelayer controls with no load, until familiar with machine operation.

**Note:** Refer to the Caterpillar operation manual for detailed information on the specific operation of the tractor unit.

## Safety

The safety section lists basic safety precautions. In addition, this section identifies the text and locations of warning signs and labels used on the machine.

Read and understand the basic precautions listed in the safety section before operating or performing lubrication, maintenance and repair on this machine.

## Operation

The operation section is a reference for the new operator and a refresher for the experienced operator. This section includes a discussion of gauges, switches, machine controls, attachment controls, transportation and towing information.

Photographs and illustrations guide the operator through correct procedures of checking, starting, operating and stopping the machine.

Operating techniques outlined in this publication are basic. Skill and techniques develop as the operator gains knowledge of the machine and its capabilities.

## Maintenance

The maintenance section is a guide to equipment care. The Maintenance Interval Schedule (MIS) lists the items to be maintained at a specific service interval. Items without specific intervals are listed under the "When Required" service interval. The Maintenance Interval Schedule lists the page number for the step-by-step instructions required to accomplish the scheduled maintenance. Use the Maintenance Interval Schedule as an index or "one safe source" for all maintenance procedures.

## Maintenance Intervals

Use the service hour meter to determine servicing intervals. Calendar intervals shown (daily, weekly, monthly, etc.) can be used instead of service hour meter intervals if they provide more convenient servicing schedules and approximate the indicated service hour meter reading. Recommended service should always be performed at the interval that occurs first. Under extremely severe, dusty or wet operating conditions, more frequent lubrication than is specified in the maintenance intervals chart might be

necessary. Perform service on items at multiples of the original requirement. For example, at every 500 service hours or 3 months, also service those items listed under every 250 service hours or monthly and every 10 service hours or daily.

## Safety Section

Certain conditions and precautions are peculiar to pipelaying operations. The following represents the minimum considerations for safe operations.

### Safety Messages – VP 72Gs2 Pipelayer Kit

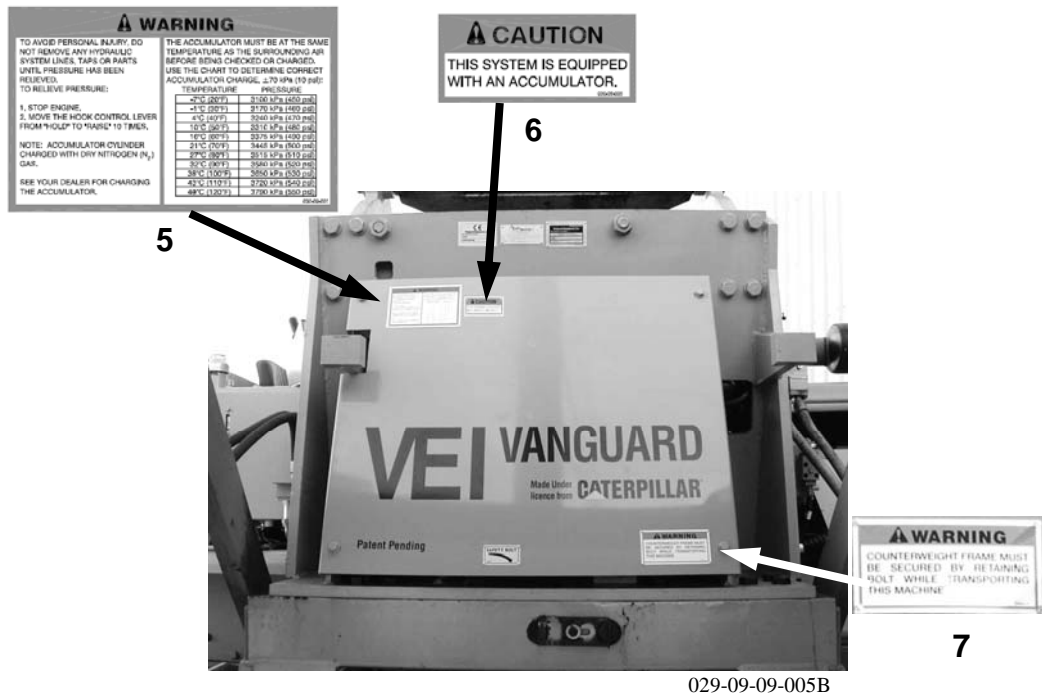
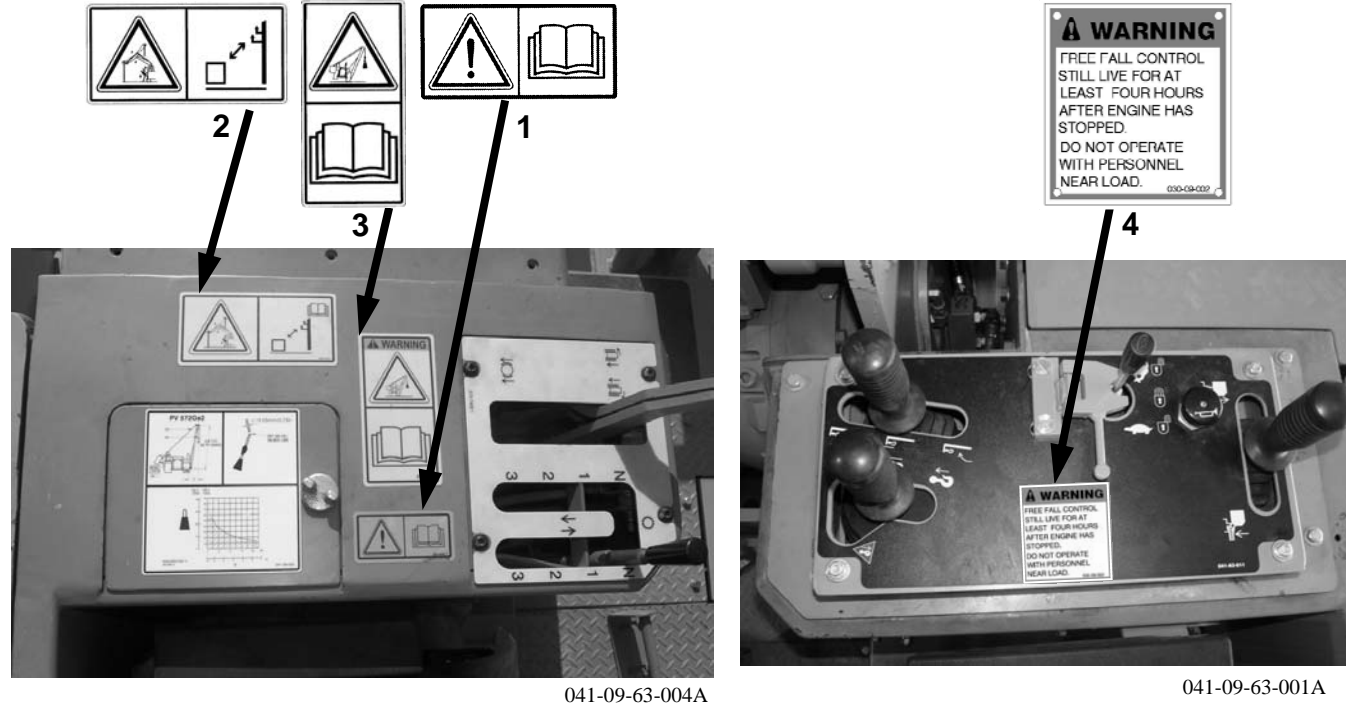

Figure 1: Safety Messages VP 72Gs2

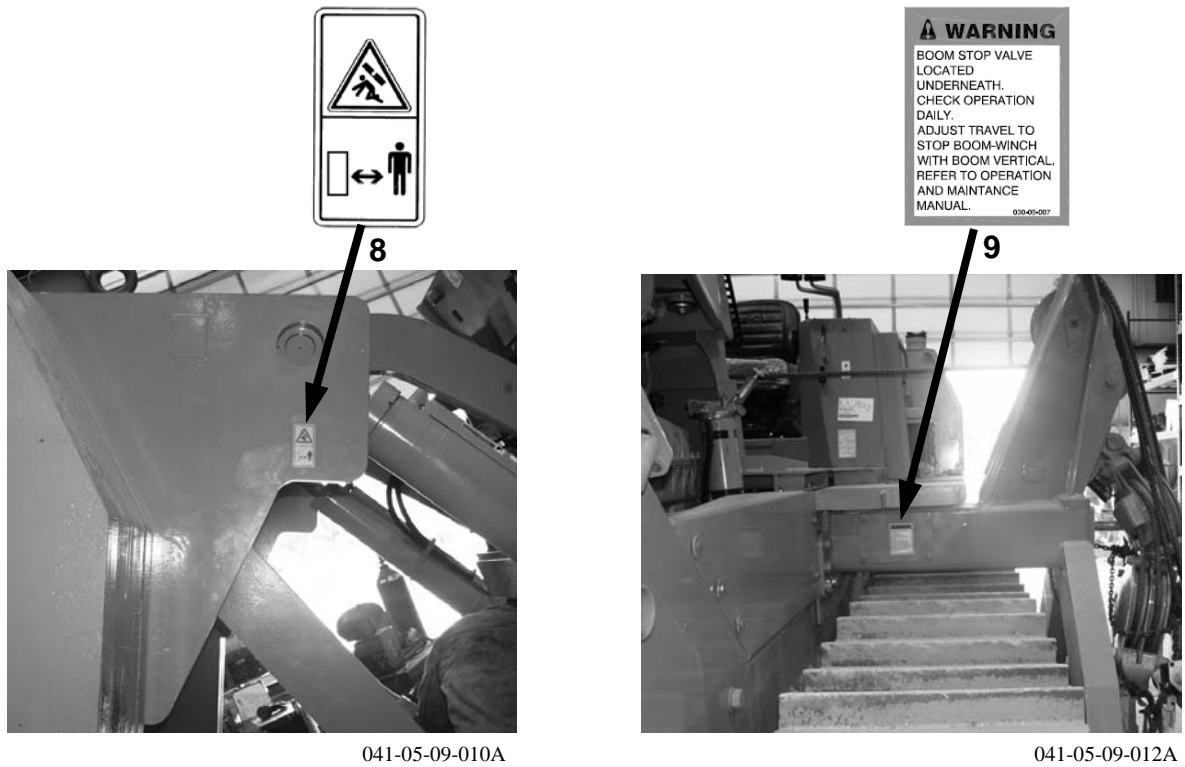

Figure 2: Safety Messages VP 72Gs2

There are several specific safety messages on this machine. The exact location of the hazards and the description of the hazards are reviewed in this section. Please become familiarized with all safety messages.

Make sure that all of the safety messages are legible. Clean the safety messages or replace the safety messages if you cannot read the words. Replace the illustrations if the illustrations are not visible. When you clean the safety messages, use a cloth, water, and soap. Do not use solvent, gasoline, or other harsh chemicals to clean the safety messages. Solvents, gasoline, or harsh chemicals could loosen the adhesive that secures the safety messages. Loose adhesive will allow the safety message to fall. Do not use pressure washers to clean the warning signs.

Replace any safety message that is damaged or missing. If a safety message is attached to a part of the machine that is replaced, install a safety message on the replacement part.

## Do Not Operate (1)



*Do not operate or work on this machine unless you have read and understand the instructions and warnings in the Operation and Maintenance Manuals. Failure to follow the instructions or heed the warnings could result in injury or death. Contact your dealer for replacement manuals. Proper care is your responsibility.*

Safety message (1) is located inside of the left hand operator console.

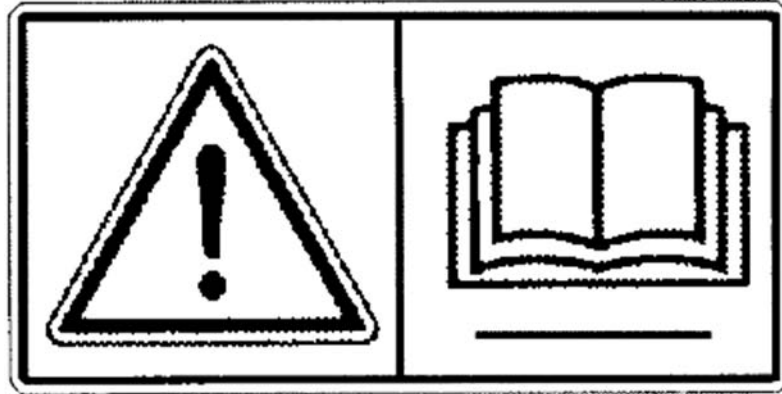

Figure 3: Do not operate (1)

## Electrical Power Lines (2)



*Electrocution Hazard! Keep the machine and attachments a safe distance from electrical power. Stay clear 3 M (10 ft) plus twice the line insulator length. Read and understand the instructions and warnings in the Operation and Maintenance Manual. Failure to follow the instructions and warnings will cause serious injury or death.*

Safety message (2) is located on the outside of the left hand operator console.

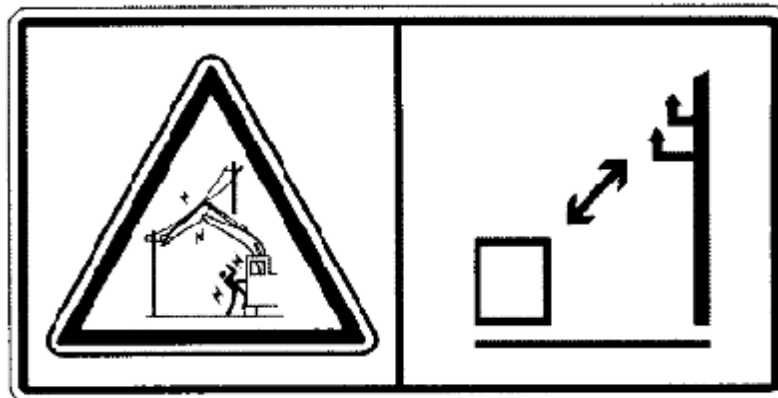

Figure 4: Electrical power lines (2)



### Tipover Hazard (3)



*The machine may tip and personal injury may occur if the maximum load capacities are exceeded. Load capacities assume that the machine is stationary on a level concrete surface with the counterweight extended. Lift capacities will decrease on slopes or soft ground. See Operation and Maintenance Manual "Lifting Capacities".*

Safety message (3) is located on the left hand console.

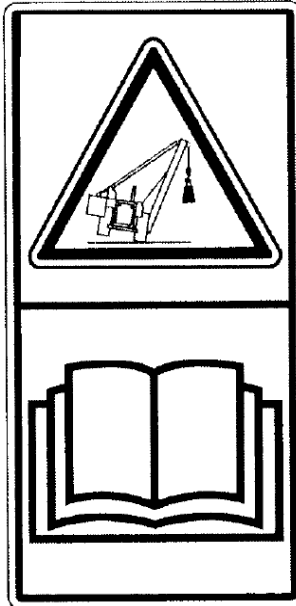

Figure 5: Tipover Warning (3)

### Free Fall Active (4)



*Dropping load hazard! The free fall control remains live for several hours after the engine has been stopped. Operation of the free fall control could cause a sudden uncontrolled drop of any supported load. Do not operate the free fall control when personnel are near a suspended load, even with the engine stopped*

Safety message (4) is located in the middle of the winch drawworks control panel.



Figure 6: Free Fall active warning (4)

## Hydraulic Accumulator (5, 6)

# **WARNING**

**High Pressure Cylinder: Rapid discharging from disconnecting or disassembly or failure to follow the instructions and warnings could cause an explosion, resulting in possible injury or death. Do not expose to fire. Do not weld. Do not drill. Do not remove any hydraulic system lines, taps or parts until pressure has been relieved. Relieve pressure before discharging. See Operation and Maintenance Manual "Accumulator" for charging and discharging. See your Dealer for tools and detailed information. Precharge only with dry nitrogen gas.**

Safety message (5) is attached to the outside guard of the winch drawworks between the winch drawworks and the counterweight group.

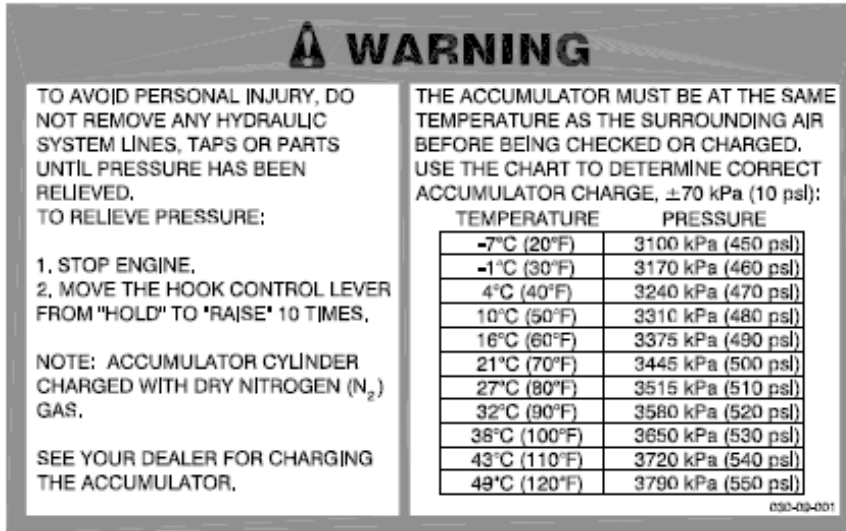

**WARNING**

TO AVOID PERSONAL INJURY, DO NOT REMOVE ANY HYDRAULIC SYSTEM LINES, TAPS OR PARTS UNTIL PRESSURE HAS BEEN RELIEVED.

TO RELIEVE PRESSURE:

1. STOP ENGINE.
2. MOVE THE HOOK CONTROL LEVER FROM "HOLD" TO "RAISE" 10 TIMES.

NOTE: ACCUMULATOR CYLINDER CHARGED WITH DRY NITROGEN (N<sub>2</sub>) GAS.

SEE YOUR DEALER FOR CHARGING THE ACCUMULATOR.

THE ACCUMULATOR MUST BE AT THE SAME TEMPERATURE AS THE SURROUNDING AIR BEFORE BEING CHECKED OR CHARGED. USE THE CHART TO DETERMINE CORRECT ACCUMULATOR CHARGE, ±70 kPa (10 psf):

TEMPERATURE	PRESSURE
-7°C (20°F)	3100 kPa (450 psf)
-1°C (30°F)	3170 kPa (460 psf)
4°C (40°F)	3240 kPa (470 psf)
10°C (50°F)	3310 kPa (480 psf)
16°C (60°F)	3375 kPa (490 psf)
21°C (70°F)	3445 kPa (500 psf)
27°C (80°F)	3515 kPa (510 psf)
32°C (90°F)	3580 kPa (520 psf)
38°C (100°F)	3650 kPa (530 psf)
43°C (110°F)	3720 kPa (540 psf)
49°C (120°F)	3790 kPa (550 psf)

030-09-001

Figure 7: Hydraulic

accumulator (5)

Safety message (6) is located on the outside of the winch drawworks guard, between the winch drawworks and the counterweight group of the console.

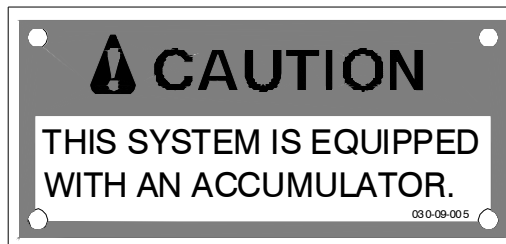

**CAUTION**

THIS SYSTEM IS EQUIPPED WITH AN ACCUMULATOR.

030-09-005

Figure 8: System equipped with an accumulator (6)

## Transportation Hazard (7)



***Secure Counterweight Frame for Transport! The counterweight may swing outward under its own weight during transporting this machine, resulting in possible injury or death. The counterweight frame must be secured by the Safety Retaining Bolt while transporting this machine. Refer to the Operation and Maintenance Manual, "Counterweight Stowing Mechanism".***

Safety message (7) is located on the outside of the winch drawworks guard, between the winch drawworks and the counterweight group of the console.



041-09-68-001

Figure 9: Transportation Warning (7)

## Counterweight Crushing Hazard (8)



***Crushing Hazard! Be sure no one is under or near the counterweight before lowering the counterweight. When the counterweight is in the fully extended position for servicing the machine, secure the extended counterweight with the counterweight lock lever. Use the counterweight lock lever to avoid possible personnel injury or death from crushing. Keep all personnel away from the counterweight when lowering the counterweight to avoid possible personnel injury or death.***

Safety message (8) is located on the front and rear sides of the upper counterweight frame, and on the front and rear counterweight swing links.



Figure 10: Counterweight crushing hazard and pinch point (8)

## Boom Stop Operation and Adjustment (9)



*The Boom Stop system stops the boom winch from hauling-in when the boom is vertical, preventing overloading of key machine components. Incorrectly adjusting, or defeating the boom stop valve could result in serious equipment damage, personal injury, or even death. Its operation must be check and verified daily.*

Safety message (9) is located inside of the left hand pipelayer frame at the front side, on the boom stop valve access panel.

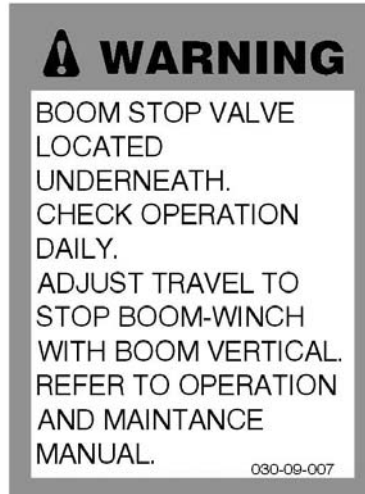

Figure 11: Boom stop valve (9)

### **Before Operation**

Clear all personnel from the machine and from the area.

Remove all obstacles from the path of the machine. Beware of hazards such as wires, ditches, etc.

Make sure that the machine horn, the backup alarm (if equipped) and all other warning devices are working properly.

**Reference:** Refer to Operation and Maintenance Manual, "Daily Inspection" in this manual and in the Tractor's manual.

Fasten the seat belt securely.

### **Visibility Information**

Before you start the machine, the operator shall perform a walk-around inspection in order to ensure that there are no hazards around the machine.

While the machine is in operation, the operator should constantly survey the area around the machine. The operator needs to identify potential hazards as a hazard becomes visible around the machine.

Your machine may be equipped with mirrors or other visual aids. An example of a visual aid is Closed Circuit Television (CCTV). The operator should ensure that the visual aids are in proper working condition and that the visual aids are clean. Adjust the visual aids for the best visibility of all areas around the machine.

It may not be possible to provide direct visibility on large machines to all areas around the machine. Appropriate job site organization is required in order to minimize hazards that are caused by restricted visibility. Job site organization is a collection of rules and procedures that coordinates machines and people that work together in the same area.

The operator is required to survey his/her field of vision when operating the machine.

The operator shall take notice of the areas of the reduced visibility characteristics of the machine.

Examples of job site organization include the following:

- Safety instructions
- Controlled patterns of machine movement
- Controlled patterns of vehicle movement
- Restricted areas
- Operator training
- Warning symbols or warning signs on machines or on vehicles
- A system of communication
- Communication between workers and operators prior to approaching the machine

## **Operation**

### **Machine Operating Temperature Range**

The standard pipelayer component configuration is intended for use within an ambient temperature range of -40 °C (-40 °F) to 50 °C (122 °F). Special configurations for different ambient temperatures may be available. Consult your dealer for additional information. Refer to the specific tractor Operation and Maintenance manual for standard tractor capabilities.

### **Machine Operation**

Only operate the machine while you are in a seat. The seat belt must be fastened while you operate the machine. Only operate the controls while the engine is running.

Before you move the machine, make sure that no one will be endangered.

Check for proper operation of all controls and protective devices while you operate the machine slowly in an open area. Do not allow riders on the machine unless the machine has the following equipment:

- additional seat
- additional seat belt

Report any needed repairs that were noted during operation.

Do not go close to the edge of a cliff, an excavation, or an overhang.

If the machine begins to sideslip, turn the machine downhill.

Be careful to avoid any condition which could cause the machine to tip. The machine can tip when you work on hills, banks and slopes. Also, the machine can tip when you cross ditches, ridges or other obstacles.

Whenever it is possible, operate the machine up the slopes and down the slopes. Avoid operating the machine across the slope, when possible.

Keep the machine under control. Do not overload the machine beyond capacity.

Be sure that the towing eyes and towing devices are adequate.

Towing eyes and towing devices should only be used to recover the machine.

Connect trailing equipment to a drawbar or to a hitch only.

When you maneuver the machine to connect equipment, be sure that there are no personnel between the machine and the trailing equipment. Block the hitch of the trailing equipment in order to align the equipment with the drawbar.

Never straddle a wire cable or allow other personnel to straddle a wire cable.

Know the maximum dimensions of your machine.

## **Lifting Capacities**

Maintain control of the machine. Do not overload the machine beyond the machine capacity. Ensure that the correct load chart is referenced. Loads must be within the capabilities of the machine. Lifting capacity decreases as the load is moved further from the machine.

Use lifting slings that are approved and use lifting slings that are load tested. Also, all wire ropes or chains must be properly maintained. The wire ropes and chains must meet local regulations. You must know the load carrying capacity of these devices and you must know the correct use of these devices.

Wire rope limitations, soil conditions, and slope of terrain reduce actual capacity. All lifts must be made with the load line vertical, and the boom centerline directed toward the load.

To prevent cable from slipping off the drum, a minimum of five full-wraps of cable must remain on the winch drum at maximum working extension of the hook or boom.

### **Limitations on Lifting Loads That Exceed the Working Range**

Do not load the boom beyond the maximum load capacity. See Operation and Maintenance Manual, "Lifting Capacities" for the load capacity of the boom.

When the load capacity is exceeded, refer to "American National Standards ANSI/ASME B30.14".

Also, follow the procedures that are listed below:

- Inspect the wire cable for defects prior to the lift operation
- Inspect the wire cable for defects after the lift operation
- Do not exceed the load capacity of the boom
- The load must be handled safely in order to minimize tipping effects
- The lift operation and the inspections must be made under controlled conditions by a competent, authorized person

## Electrical Power Lines



*Serious injury or death by electrocution can result if the machine or attachments are not kept the proper distance from electrical power lines.*

Use the following chart, and refer to ANSI/ASME B30.14-3.4.2 in order to determine the safe distance from high voltage wires during these conditions:

- machine operation
- machine transportation

<b>When Operating Near High Voltage Power Lines</b>	
<b>Normal Voltage (Phase to Phase)</b>	<b>Minimum Clearance Required</b>
0 Volts to 50 kVolts	3.05 Meters (10 Feet)
Over 50 kVolts to 200 kVolts	4.60 Meters (15 Feet)
Over 200 kVolts to 350 kVolts	6.10 Meters (20 Feet)
Over 350 kVolts to 500 kVolts	7.62 Meters (25 Feet)
Over 500 kVolts to 750 kVolts	10.67 Meters (35 Feet)
Over 750 kVolts to 1000 kVolts	13.72 Meters (45 Feet)
<b>While in Transit Near High Voltage Power Lines</b>	
<b>Normal Voltage (Phase to Phase)</b>	<b>Minimum Clearance Required</b>
0 Volts to 0.75 kVolts	1.22 Meters (4 Feet)
Over 0.75 kVolts to 50 kVolts	1.83 Meters (6 Feet)
Over 50 kVolts to 345 kVolts	3.05 Meters (10 Feet)
Over 345 kVolts to 750 kVolts	6.10 Meters (20 Feet)
Over 750 kVolts to 1000 kVolts	7.62 Meters (25 Feet)

Table 1: Power lines, minimum clearance

### **Parking**

Park on a level surface. If you must park on a grade, use blocks to prevent the machine from rolling.

Apply the service brake in order to stop the machine. Move the transmission control lever to NEUTRAL position and move the engine speed switch to the LOW IDLE position. Engage the parking brake.

Lower any load to the ground and fully retract the counterweight.

Refer to the tractor's operation and maintenance manual for the specific procedures regarding engine shut down and/or other implement attachments.

## Slope Operation

Machines that are operating safely in various applications depend on these criteria: the machine model, configuration, machine maintenance, operating speed of the machine, conditions of the terrain, fluid levels. The most important criteria are the skill and judgment of the operator.

A well trained operator that follows the instructions in the Operation and Maintenance Manual has the greatest impact on stability. Operator training provides a person with the following abilities: observation of working and environmental conditions, feel for the machine, identification of potential hazards, and operating the machine safely by making appropriate decisions.

When you work on side hills and when you work on slopes, consider the following important points:

**Speed of travel** - At higher speeds, forces of inertia tend to make the machine less stable.

**Roughness of terrain or surface** - The machine may be less stable with uneven terrain.

**Direction of travel** - Avoid operating the machine across the slope. When possible, operate the machine up the slopes and operate the machine down the slopes. Place the heaviest end of the machine uphill when you are working on an incline.

**Mounted equipment** - Balance of the machine may be impeded by the following components: equipment that is mounted on the machine, machine configuration, weights, and counterweights.

**Nature of surface** - Ground that has been newly filled with earth may collapse from the weight of the machine.

**Surface material** - Rocks and moisture of the surface material may drastically affect the machine's traction and machine's stability. Rocky surfaces may promote side slipping of the machine.

**Slippage due to excessive loads** - This may cause downhill tracks or downhill tires to dig into the ground, which will increase the angle of the machine.

**Width of tracks** - Narrower tracks further increase the digging into the ground which causes the machine to be less stable.

**Implements attached to the drawbar** - This may decrease the weight on the uphill tracks. The decreased weight will cause the machine to be less stable.

**Height of the working load of the machine** - When the working loads are in higher positions, the stability of the machine is reduced.

**Operated equipment** - Be aware of performance features of the equipment in operation and the effects on machine stability.

**Operating techniques** - Keep all attachments or pulled loads low to the ground for optimum stability.

**Machine systems have limitations on slopes** - Slopes can affect the proper function and operation of the various machine systems. These machine systems are needed for machine control on slopes.

**Note:** Safe operation on steep slopes may require special machine maintenance. Excellent skill of the operator and proper equipment for specific applications are also required. Consult the Operation and Maintenance Manual sections for the proper fluid level requirements and intended machine use.

**Note:** Refer to the tractor's operation and maintenance manual for further specific requirements for safe operation on steep slopes.



## Guards

There are different types of guards that are used to protect the operator.

A daily inspection of the guards is required in order to check for structures that are bent, cracked or loose. Never operate a machine with a damaged structure.

The operator becomes exposed to a hazardous situation if the machine is used improperly or if poor operating techniques are used. This situation can occur even though a machine is equipped with an appropriate protective guard. Follow the established operating procedures that are recommended for your machine.

## Product Information Section

### General Information

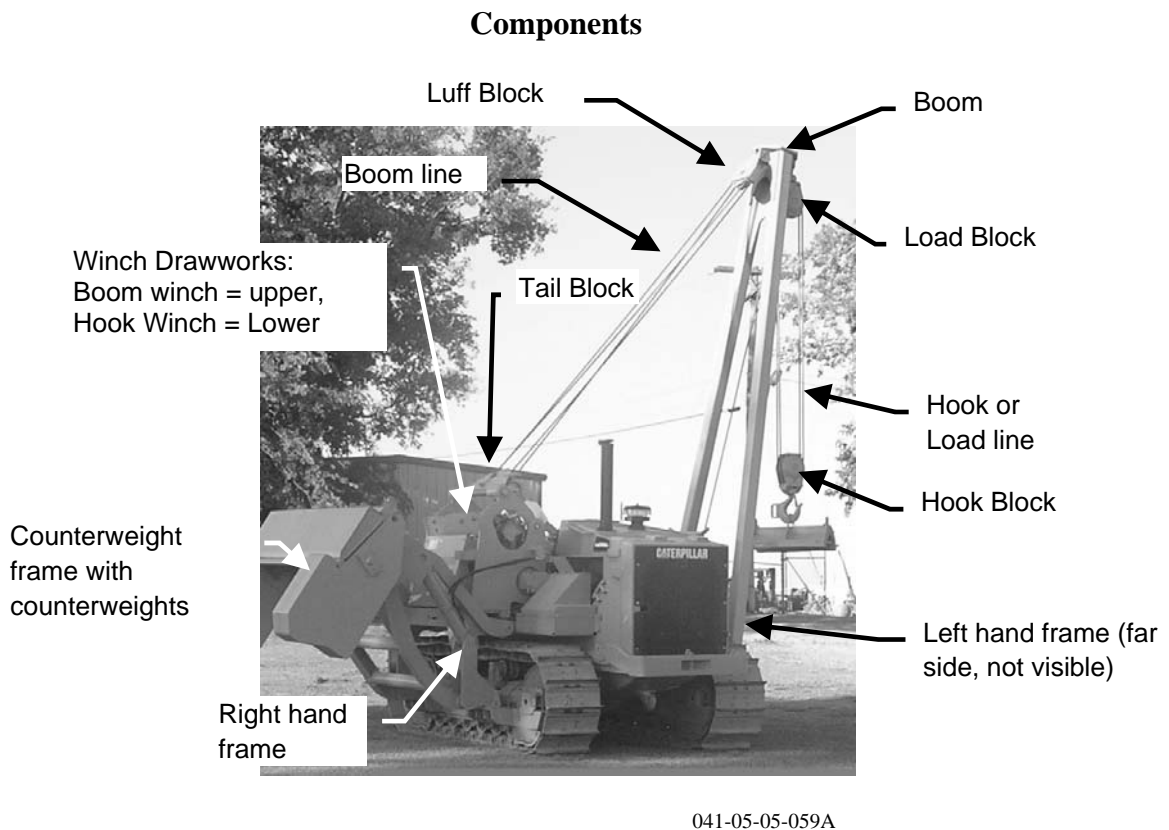

Figure 12: Component identification

## Specifications

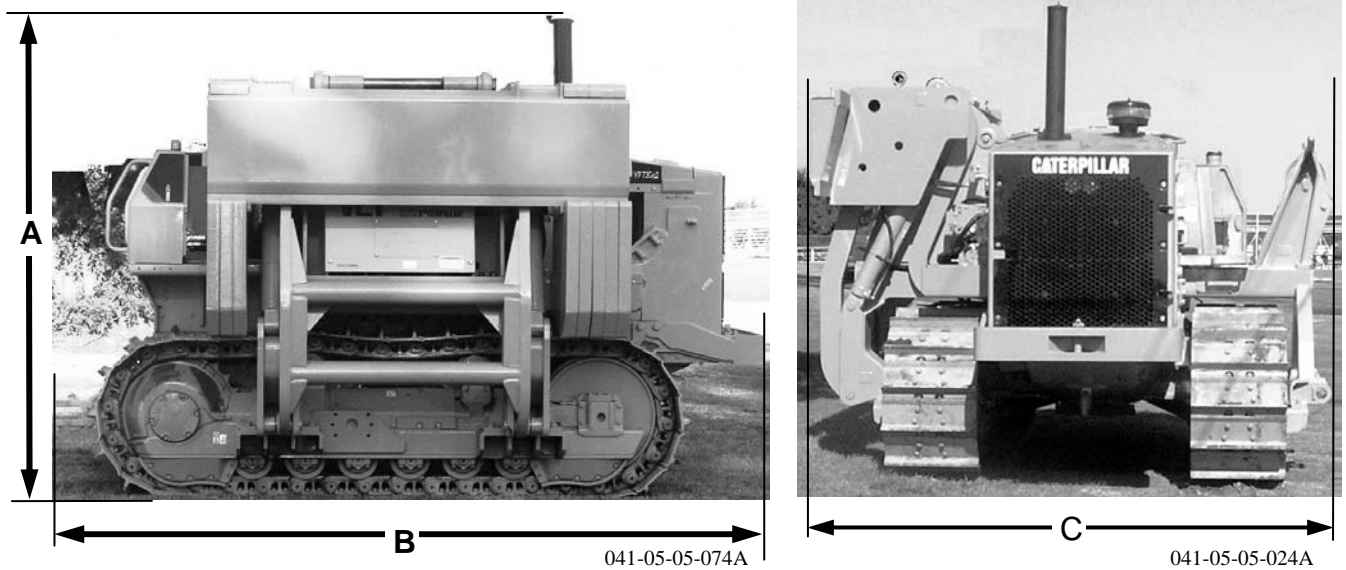

Figure 13: Standard shipping specifications, height and width

<b>VP 72Gs2 Pipelayer</b>	
<b>Approximate operating weight of the standard machine<sup>1</sup></b>	29910 kg (65940 lb)
<b>Approximate shipping weight of the standard machine<sup>2</sup></b>	29593 kg (65240 lb)
<b>Weight of the boom, the boom sheave blocks, and the load blocks</b>	1174 kg (2585 lb)
<b>Height of the machine without the boom (A)</b>	3050 mm (10 feet)
<b>Length of the machine (B)</b>	4623 mm (15 feet 2 inch)
<b>Width of the machine without the boom (C)</b>	3658 mm (12 feet)
<b>Height of the machine with the boom</b>	6833 mm (22 feet 5 inch)
<b>Ground clearance of the machine</b>	349 mm ( 1 foot 1-3/4 inch)

Table 2: Specifications

### Intended Use

This machine is a Pipelayer that is described in ISO 6165:2001. The machine is intended to perform the following functions: lift, handle, and lay down pipe with a side mounted boom.

### Restrictions to Application and Configuration

The maximum lift capacity is 40820 kg (90,000 lb).

The maximum fore and aft slope is 45 degrees or a 100 percent grade for the proper lubrication of the pipelayer components.

Refer to the tractor operation and maintenance manual for additional restrictions.

<sup>1</sup> Operating Weight: Includes lubricants, coolant, 100% fuel, hydraulic controls and fluids, backup alarm, seat belt, 610 mm (24 in) single grouser shoes, drawbar, counterweight, boom and pulley blocks and cable, and operator.

<sup>2</sup> Shipping Weight: Includes lubricants, coolant, 10% fuel, hydraulic controls and fluids, backup alarm, seat belt, 610 mm (24 in) single grouser shoes, drawbar, counterweight, and pulley blocks and cable.

## Lifting Capacities



*The machine may tip and personal injury may occur if the maximum load capacities are exceeded. Load capacities assume that the machine is stationary on a level concrete surface with the counterweight extended. Lift capacities will decrease on slopes or soft ground.*

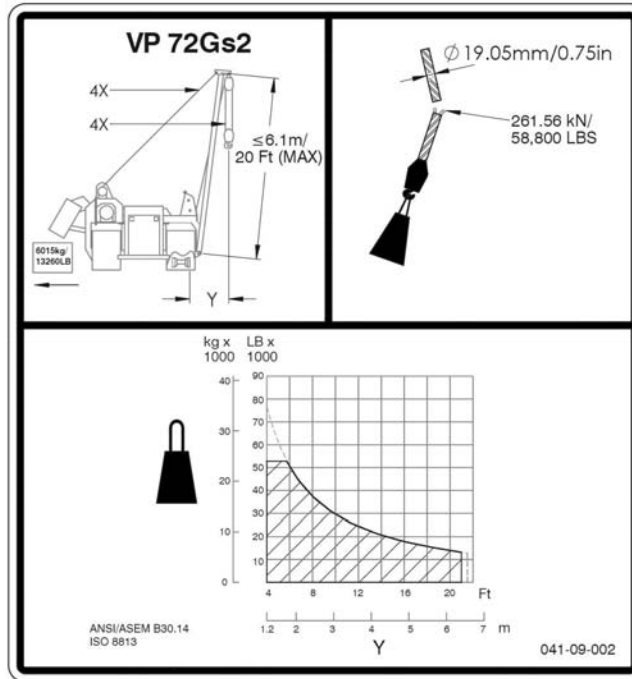

041-09-09-002A

Figure 14: Lifting Capacities

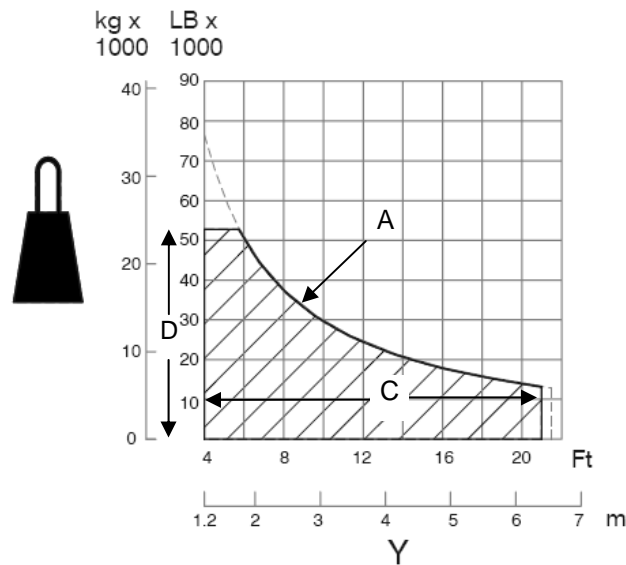

041-09-09-002A

Figure 15: Lift capacity chart

The following are as per ANSI/ASME B30.14, ISO 8813: 1992:

- (A) Rated load/lift capacity
- (Y) W12 Load overhang
- (C) Rated load/lift capacity working range
- (D) Maximum load/lift capacity range

**NOTE:** Do not exceed the lifting capacity that is shown in the chart in illustration above.

The lift capacity chart is located on the left hand side of the operator's console to the rear of the tractor controls. The lift capacities are based on a stationary machine with the following specifications:

VP 72Gs2 Pipelayer	
Wire rope diameter	19.05 mm ( 0.75 inch)
Minimum breaking strength of the wire rope	261.56 kN (58,800 lb)
4 part load line	
4 part boom line	
Mass of the extended counterweight	6015 kg ( 13260 lb)
Standard boom length	6.1 m (20 ft)
Total operating weight of the machine <sup>3</sup>	29910 kg (65940 lb)

Table 3: Stationary specifications

If the lift capacity chart indicates that the lift operation is within the capability of the machine, attempt to perform the operation but proceed with care. Remember that the load may weigh more than the estimate for the load. The lift capacity chart is for estimating the lift operation only.

## Operation Section

### Before Operation

#### Mounting and Dismounting



Figure 16: Mounting and dismounting machine

Use steps and handholds whenever you mount the machine. Use steps and handholds whenever you dismount the machine. Before you mount the machine, clean the step and the handholds. Inspect the step and handholds. Make all necessary repairs.

Face the machine whenever you mount the machine and whenever you dismount the machine. Maintain a three-point contact with the step and with handholds.

**Note:** Three-point contact can be two feet and one hand. Three-point contact can also be one foot and two hands.

Do not mount a moving machine. Do not dismount a moving machine. Never jump off the machine. Do not try to mount the machine when you carry tools or supplies. Do not try to dismount the machine when you are carrying tools or supplies. Use a hand line to pull equipment onto the platform. Do not use any controls as handholds when you enter the operator compartment or when you exit the operator compartment.

<sup>3</sup> Operating Weight: Includes lubricants, coolant, 100% fuel, hydraulic controls and fluids, backup alarm, seat belt, 610 mm (24 in) single grouser shoes, drawbar, counterweight, boom and pulley blocks and cable, and operator.

## Daily Inspection



041-05-05-055A

Figure 17: Daily inspection walk around

For maximum service life of the machine, perform a daily walk-around inspection.

**Note:** Watch closely for leaks. If leaking is observed, find the source of the leak and correct the leak. If leaking is suspected or leaking is observed, check the fluid levels more frequently.

Inspect the machine for the following items:

- Inspect the hydraulic system for leaks. Repair any hydraulic system leaks. Inspect the hoses, the seals, and the flanges.
- Inspect the winch final drive for leaks. Repair any final drive leaks.
- Inspect covers and the guards for damage, for loose bolts, and for missing bolts.
- Inspect the condition of the steps and of the handholds. Inspect the steps and the handholds for cleanliness. If necessary, repair the steps or clean the steps.
- Inspect the operator compartment for cleanliness. Remove any trash buildup and any dirt buildup.
- Inspect mirrors and make sure they are in good condition and replace if broken.

**Note:** Refer to the tractor operation manual for detailed information on the specific daily inspection of the tractor unit.

---

### NOTICE

Accumulated grease and oil on a machine is a fire hazard.

Remove debris with steam cleaning or high pressure water, at the specified interval in the Maintenance Interval Schedule or each time any significant quantity of oil is spilled on the machine.

---

## Daily Checks

After you inspect the machine, perform the daily maintenance that is listed in the maintenance interval schedule. Perform the daily maintenance before you mount the machine in order to operate the machine.

Refer to Operation and Maintenance Manual, "Maintenance Interval Schedule" for the correct procedures for the following checks:

- "Boom Pivot Pins - Lubricate"
- "Cooling System Coolant Level - Check"
- "Counterweight Cylinder Bearings - Lubricate"
- "Counterweight Hinge Pins - Lubricate"
- "Fairlead Sheave - Lubricate"
- "Hook and Wire Cable Inspect"
- "Hydraulic System Oil Level - Check"
- "Sheave Block Bearings - Lubricate"
- "Boom Stop Valve - Check operation"
- 

**Note:** Refer to the tractor operation manual for detailed information on the specific daily checks of the tractor unit.

## Tractor Operation

Refer to the tractor's operation and maintenance manual for the specific procedures regarding complete Tractor Operation.

## Hydraulic Oil Temperature

Refer to the tractor's operation and maintenance manual "Gauges" for the specific procedures regarding hydraulic oil temperature indication and operating temperature.

## Pipelayer Operation

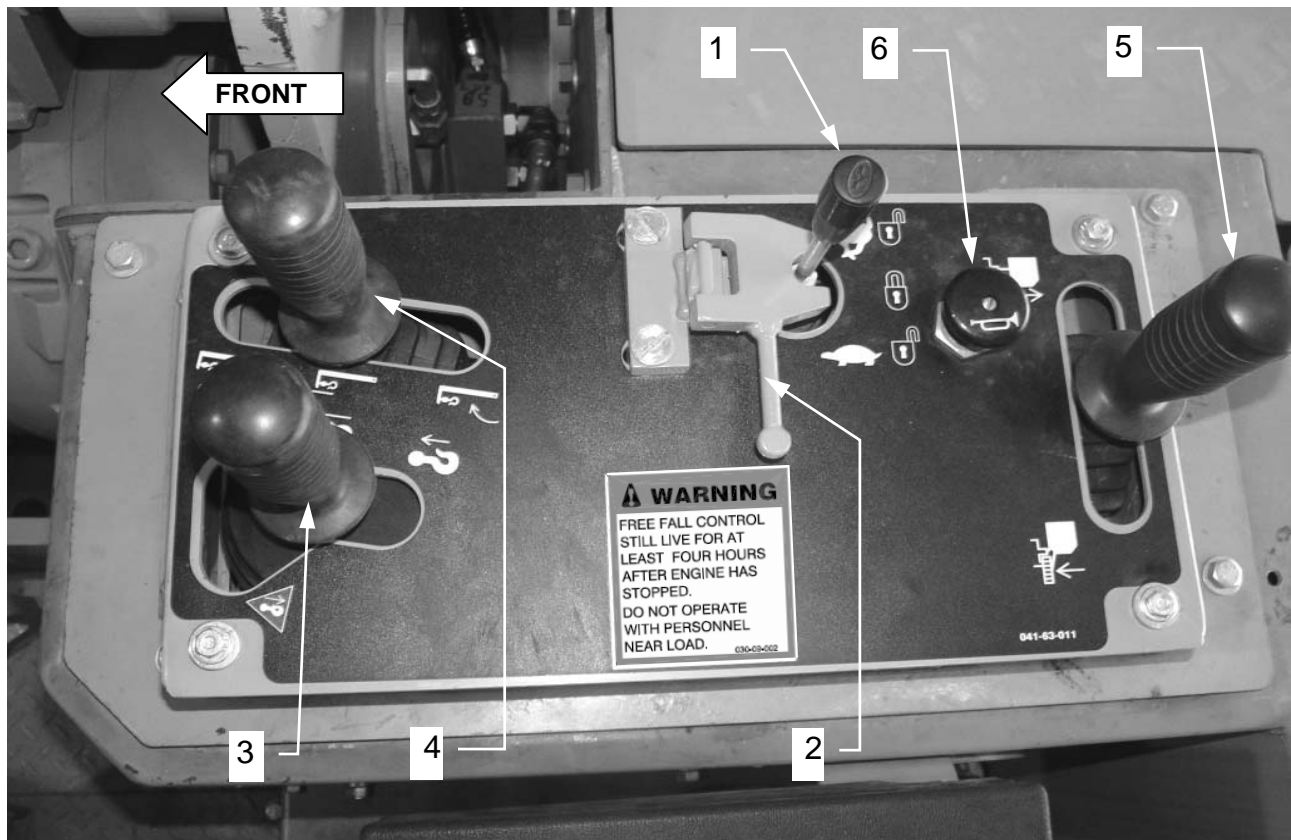

041-09-63-001B

Figure 18: Controls for hook

### Speed/Lockout Control Lever (1)

The speed/lockout control lever has three positions that controls the speed range of the hook winch and prevents accidental actuation of the pipelayer-controls while not in use.



**HIGH SPEED MODE—WINCH CONTROLS UNLOCKED:** Push the speed/lockout control lever forward for the hook winch at high speed range, the maximum hook winch pull is reduced; the boom winch speed is unaffected.



**LOCKED MODE—WINCH AND COUNTERWEIGHT CONTROLS LOCKED:** To prevent accidental actuation of the controls while not in use, move the speed/lockout control lever to the centre position and flip the speed/lockout control lock to engage the lever (2) and lock it in position. In this mode, the hook winch (3), boom winch (4), and counterweight (5) controls do not function. **Always** place the speed/lockout control lever in the **LOCKED MODE** **and** engage the speed/lockout control lock whenever the machine is left unattended, or when inadvertent control operation could result in a dangerous situation arising.



**LOW SPEED MODE—WINCH CONTROLS UNLOCKED:** Pull the speed/lockout control lever back for the hook winch low speed range, maximum hook winch pull is available; the boom winch speed unaffected.

## Speed/Lockout Control Lock (2)

Use the speed/lockout control lock lever (2) to lock the speed/lockout control lever (1) in the LOCKED MODE position.

Move the hook control lever (3) to HOLD position. Move the boom control lever (4) to HOLD position. Move the counterweight control lever (5) to HOLD position. Move the speed/lockout control lever to the centre position. Flip the speed/lockout control lever over the control lever in order to lock the lever in the LOCKED MODE position. This locks the hook controls, the boom controls, and the counterweight controls in HOLD in order to prevent accidental hook movement, boom movement, or counterweight movement.

Flip the speed/lockout control lock away from the speed/lockout control lever in order to allow actuation of the speed/lockout control lever. Move the speed/lockout control lever to the desired speed range in order to operate the winches or counterweight.

Always move the speed/lockout control lever to the "**LOCKED**" position before shutting off the engine or immediately after the engine quits running to prevent unintentional load release or—after the engine is restarted—unintentional drawworks operation.

## Hook Control (3)



**HOLD:** The lever self centres to this position whenever it is released. In this position, the load winch brake will set, and the hook will stop and remain at the position it is in.



**(Emergency Lower) Free Fall -** Move the hook control lever to this position to lower the load fast in an emergency. The load winch's free fall brake will release, and the hook will move down under the weight of the load. The lever will return to the "**HOLD**" position when released, the load winch's free fall brake will set and the hook will stop and remain at the position it is in.

**NOTE:** Free Fall is only available in pipelay HIGH or LOW SPEED mode—Winch Controls Unlocked.



**LOWER:** Move the lever to this position to lower the hook with controlled winch power. The further the lever is pushed away from HOLD, the faster the hook will lower. The closer the lever is toward HOLD, the slower the hook will lower. When the lever is released, it will return to the HOLD position, the winch brake will set, and the hook will stop and remain at the position it is in. Hook winch line speed varies with engine throttle setting. Hook control is smoothest at engine speeds faster than idle.



**RAISE:** Move the lever to this position to raise the hook. The further the lever is pulled away from "**HOLD**", the faster the hook will raise. The closer the lever is toward "**HOLD**", the slower the hook will raise. When the lever is released, it will return to the "**HOLD**" position and the hook will stop and remain at the position it is in. Hook winch line speed varies with engine throttle setting. Hook control is smoothest at engine speeds faster than idle.



**NOTE:** The hydraulic pilot system and some machine controls, namely the hook quick drop, are "**LIVE**" for as long as the accumulator holds a charge, even if the engine is not running. This pressure charge will take approximately four hours or more to bleed off. Refer to the operation and maintenance manual "Free Fall Active" for dropping load hazard warning. Refer to the operation and maintenance manual "Accumulator - Relieving Charge" to bleed off the residual pressure if required and when safe to do so.

## Accumulator - Relieving Charge

To relieve the accumulator charge, with no load on the hook and the engine stopped, move the *hook control* lever from "**HOLD**" to "**RAISE**" 10 times.



## Boom Control (4)

- A)  **HOLD:** The lever self centres to this position whenever it is released. In this position, the boom winch brake will set, and the boom will stop and remain at the position it is in.
- B)  **LOWER:** Move the lever to this position to lower the boom. The further the lever is pushed away from HOLD, the faster the boom will lower. The closer the lever is toward HOLD, the slower the boom will lower. When the lever is released, it will return to the HOLD position, and the boom will stop and remain at the position it is in. Boom winch line speed varies with engine throttle setting. Boom control is smoothest at engine speeds faster than idle.
- C)  **RAISE:** Move the lever to this position to raise the boom. The further the lever is pulled away from HOLD, the faster the boom will raise. The closer the lever is toward HOLD, the slower the boom will raise. When the lever is released, it will return to the HOLD position, and the boom will stop and remain at the position it is in. Boom winch line speed varies with engine throttle setting. Boom control is smoothest at engine speeds faster than idle.

## Boom Stop Valve

The Boom Stop valve is a safety device that is intended to automatically stop the boom winch from hauling-in when the boom is vertical, preventing overloading of key machine components. Refer to the Operation and Maintenance manual, Boom Stop Valve Adjustment, for correct operation and adjustment. Check its function daily.

## Counterweight Control (5)

### NOTICE

*In order to prevent machine damage, check to make sure the safety retaining bolt in the Counterweight Stowing Mechanism is removed and in the bolt is in the stowed position before you operate this control lever; refer to the Operation and Maintenance Manual, "Counterweight Stowing Mechanism".*

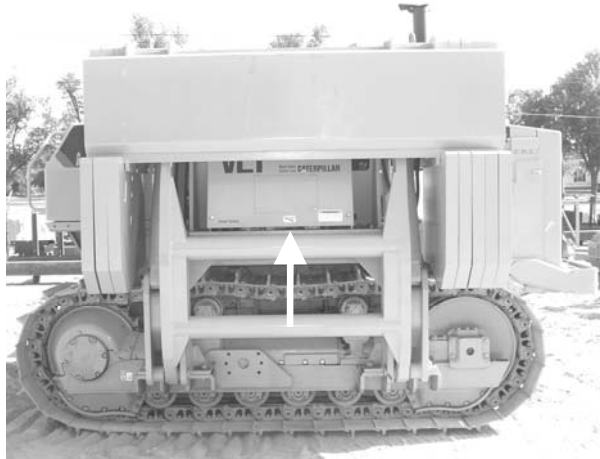

Figure 19: Remove safety bolt before operating counterweight.

041-05-68-023



**Hold** - When the operator releases the counterweight control lever from any position, the lever will return to the HOLD and the counterweight will remain in position.



**Out** - Move the counterweight control lever to this position in order to move the counterweight outward. When the counterweight control lever is released, the lever returns to the HOLD position and the counterweight will remain in position.



**In** - Move the counterweight control lever to this position in order to move the counterweight inward. When you release the counterweight control lever the lever returns to the HOLD position and the counterweight will remain in position.

Refer to the Operation and Maintenance Manual, "Counterweight Stowing Mechanism" for the procedure to lock the counterweight in the fully retracted position when you transport the machine.

### Horn location moved (6)

**NOTE:** New location of this tractor's control, refer to the tractors operation and maintenance manual for correct operation.

# Transportation Information

## Shipping the Machine

Investigate the travel route for overpass clearances. Make sure that there is adequate clearance for the machine that is being transported.

Remove ice, snow, or other slippery material from the loading dock and from the truck bed before loading. Removing ice, snow, or other slippery material will prevent slippage while you load the machine. Removing ice, snow, or other slippery material will prevent the machine from slipping in transit.

---

### NOTICE

Obey all state and local laws governing the weight, width, and length of a load. Observe all regulations governing wide loads.

---

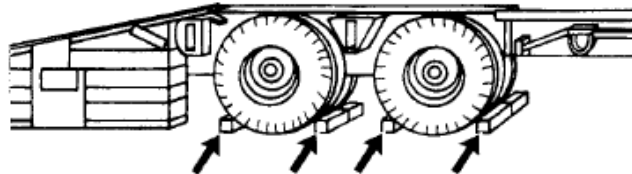

1. Place blocks under the trailer wheels or under the rail car wheels before loading, as shown.
2. Move the transmission control lever to the NEUTRAL position.
3. Engage the parking brake switch.
4. Stop the engine.
5. Turn the start switch key to the OFF position. Remove the key and lock the parking brake switch.
6. Turn the battery disconnect switch to the OFF position. Remove the key.
7. Attach any vandalism protection and lock the access covers.
8. Install the tie-downs at several locations and chock the tracks in the front and in the rear.
9. Cover the opening for the engine exhaust in order to prevent rotation of the turbocharger that is caused by the force of the wind.

---

### NOTICE

Rotation of the turbocharger without engine operation can result in damage to the turbocharger. Cover the exhaust opening or secure the rain cap in order to prevent the turbocharger from wind milling in transit. Refer to the tractor operation and maintenance manual for additional requirements and information.

---

## Removal of the Boom



Figure 20: Removal of the boom

041-05-05-059A

1. Lower the boom enough to remove the load blocks and the hook block.

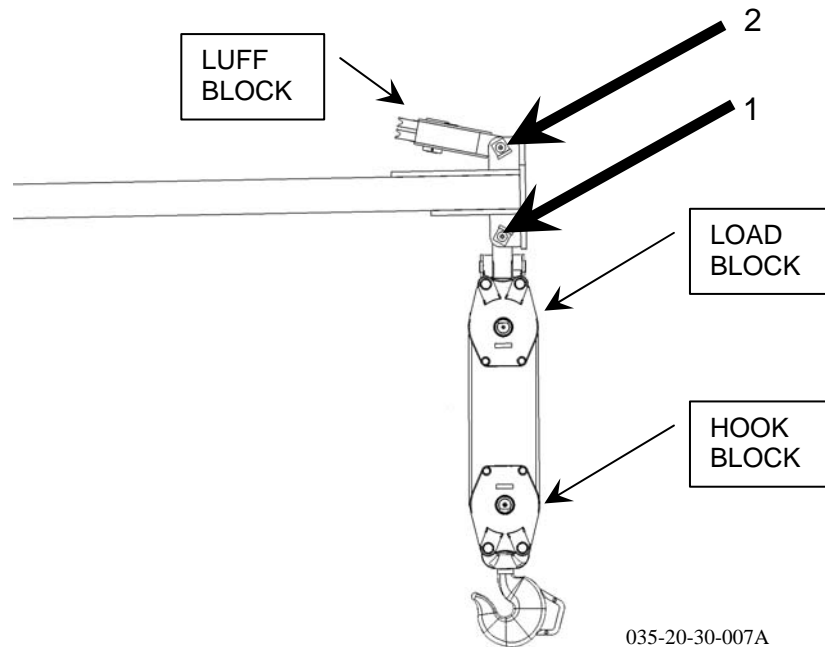

035-20-30-007A

Figure 21: Removal of boom, steps 1, 2

2. Remove cotter pin, the retainer, and pin (1). Lower the load block and the hook block to the ground.  
The approximate weight of the load block is 88 kg (194 lb). The approximate weight of the hook block is 100 kg (220 lb). The combined weight of the load block and the hook block is approximately 188 kg (414 lb).
3. Replace the pin (1) in the boom. Fasten the load block and the hook block to the machine for shipping as illustrated below. Draw in the excess hook load line.

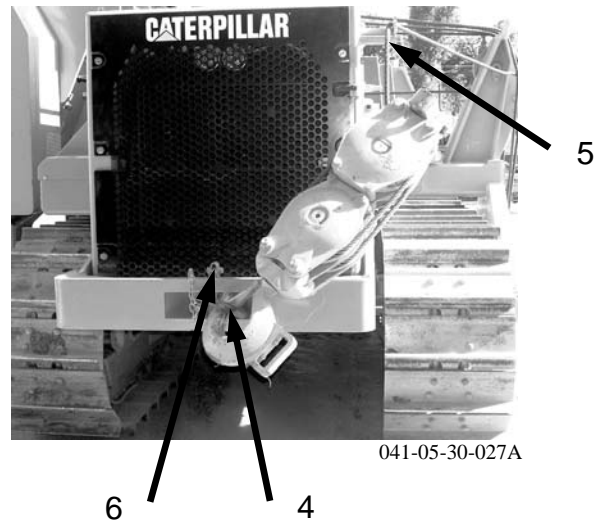
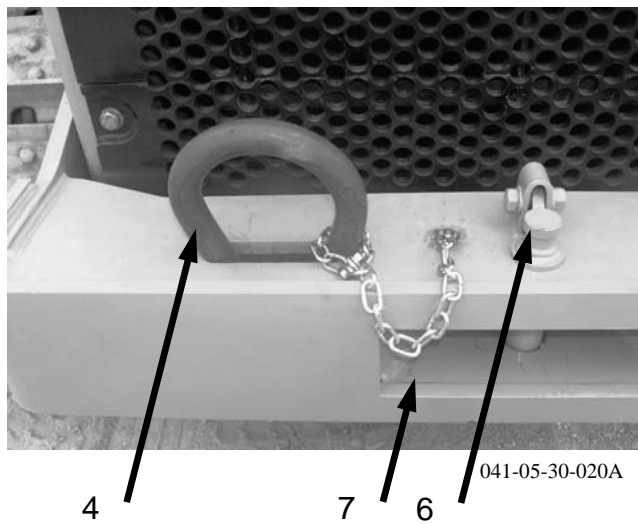

**Figure 22: Fastening of Load Blocks for Transport**

4. Remove pin (6) and insert stowing-link (4) into bumper pocket (7) and reinstall pin (6).
5. Place hook load line over guide (5).
6. Slowly draw in the excess hook load line, when the load block and hook block are suspended by the load line, swing in the load block and hook block and lock into stowing-link (4) and tighten up the load line, being careful not to kink or damage load cable.
7. To remove load block and hook block from stowing-link, reverse the above steps, and ensure the stowing-link is placed firmly back into the slot in bumper.
8. Lower the boom to the horizontal position onto wood blocks that are sufficient to support the boom.
9. Remove the cotter pin, the retainer, and pin (2). The approximate weight of the luff block is 76 kg (168 lb).
10. Replace the pin and the retainer (2) in the boom.
11. Move the luff block clear of the boom and area; it will be secured after the boom has been removed.



**Figure 23: Location of pins for removal of boom**

12. Fasten an appropriate lifting device to the boom. The approximate weight of the boom is 936 kg (2064 lb).
13. Remove the cotter pins, the retainers, and the pins (8) from both sides of the support.

14. Remove the boom from the machine. Replace the pins in the support.

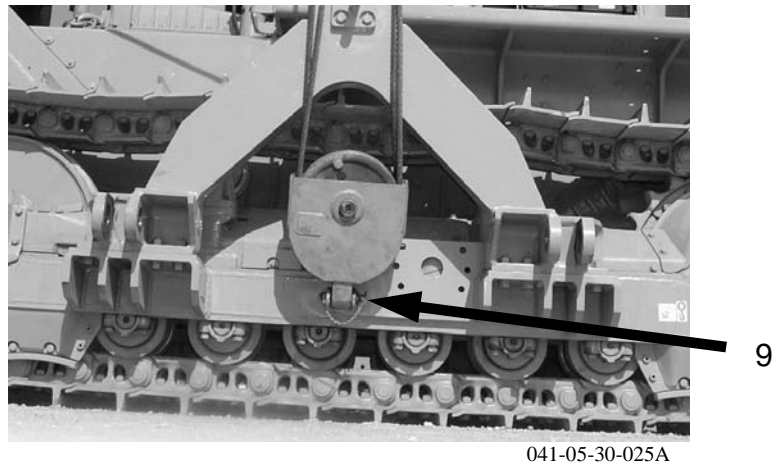

Figure 24: Location of Luff Block stowing point and stowing pin (9)

15. Draw in the line for the boom and fasten the luff block to the machine at the luff block stowing point on the track frame for shipping using stowing-pin (9).
16. Draw in the excess line for the boom, ensuring not to over tighten the cables to avoid causing kinks.

## Counterweight Stowing Mechanism

### Transportation Hazard



**Secure Counterweight Frame for Transport!** The counterweight may swing outward under its own weight during transporting this machine, resulting in possible injury or death. The counterweight frame must be secured by the Safety Retaining Bolt while transporting this machine.

The counterweight frame must be secured by the Safety Retaining Bolt while transporting this machine. The following steps outline the correct procedure to secure the counterweight for transport:

1. Fully retract the counterweight until it firmly contacts the right hand frame and fully compresses the bumper-stops.
2. The safety retaining bolt is stowed in a bracket mechanism on the inner-side of the right hand frame, above the crawler tracks.

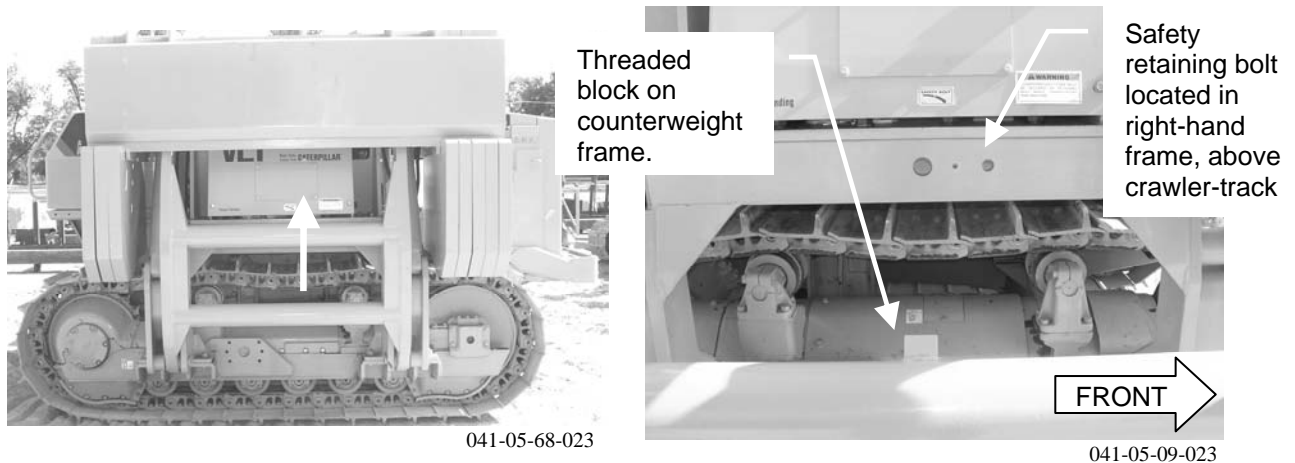

Figure 25: Safety retaining bolt location.

3. Loosen the centre 1/2-inch bolt that holds the bracket. Slide the bracket to the rear of the machine in order to remove the 1-inch safety retaining bolt.
4. Bolt through the right hand frame to the threaded block on the counterweight frame using the stowed bolt and washer; tighten the bolt to  $900 \pm 100$  Nm ( $660 \pm 75$  lb-ft) torque, and orient the bolt-head so that the stowing mechanism bracket slides back over the safety retaining bolt to prevent it from loosening off due to vibration encountered during transport.

#### NOTICE

The counterweight uses a 1-inch 8UNC 3-inch long bolt (grade 5 or better) and an oversized 2-1/4-inch outside diameter 1-inch hardened washer (CAT# 8D-4968) to secure for transport. Ensure the correct size and grade hardware is used.

5. **Before operating the machine:** remove the safety retaining bolt and place it in the forward stowing hole. Slide the bracket forward over the 1-inch safety bolt's head and tighten the center 1/2-inch bolt to  $105 \pm$  Nm ( $75 \pm 15$  lb-ft) torque.

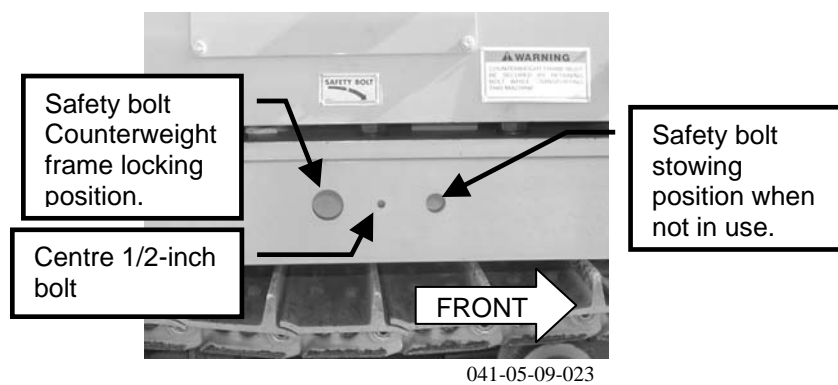

Figure 26: Safety retaining bolt use positions.

# Maintenance and Lubrication Section

## Lubricant Viscosities

### General

- Follow tractor manufacture's maintenance and lubrication instructions for tractor service as required.
- Follow tractor and/or winch manufacture's lubrication instructions for the pipelayer hydraulic system.
- To prevent corrosion damage to the winch interiors, if not used regularly, cycle the winches up and down several times at least once every two weeks.

### Selecting the Viscosity

The proper oil viscosity grade is determined by the minimum outside temperature. This is the temperature when the machine is started and when the machine is operated. In order to determine the proper oil viscosity grade, refer to the "Min" column in the table. This information reflects the coldest ambient temperature condition for starting a cold machine and for operating a cold machine. Refer to the "Max" column in the table in order to select the oil viscosity grade for operating the machine at the highest temperature that is anticipated. Use the highest oil viscosity that is allowed for the ambient temperature when you start the machine.

Machines that are operated continuously should use oils that have the higher oil viscosity in the final drives and in the differentials. The oils that have the higher oil viscosity will maintain the highest possible oil film thickness. Consult your dealer if additional information is needed.

**Lubricant Viscosities for Ambient Temperatures**

Lubricant Viscosities for Ambient Temperatures						
Compartment or System	Oil Type and Classification	Oil Viscosities	°C		°F	
			Min	Max	Min	Max
Hydraulic System	Caterpillar HYDO					
	Caterpillar DEO	SAE 0W20	-40	40	-40	104
	Caterpillar TDTO	SAE 0W30	-40	40	-40	104
	Caterpillar MTO	SAE 5W30	-30	40	-22	104
	Global DHD-1	SAE 5W40	-30	40	-22	104
	API CH-4	SAE 10W	-20	40	-4	104
	API CG-4	SAE 30	10	50	50	122
	API CF-4	SAE 10W30	-20	40	-4	104
	API CF	SAE 15W40	-15	50	5	122
	commercial TO-4	Caterpillar MTO	-25	40	-13	104
	Caterpillar TDTO-TMS	Biodegradable Hydraulic Oil	-40	43	-40	110
	Caterpillar Biodegradable Hydraulic Oil (HEES) <sup>(1)</sup>	HEES <sup>(4)</sup>				
commercial BF-1 <sup>(1)</sup>	TDTO-TMS <sup>(2)</sup>	-20	50	-4	122	

Table 4: Lubricant viscosities for ambient temperature

(1) Commercial Biodegradable Hydraulic Oil (HEES) must meet the Caterpillar BF-1 specification.

### Capacities (Refill)

APPROXIMATE REFILL CAPACITIES			
Compartment or System	Liters	US gal	Imperial gallon
Hydraulic Oil (Tank only)	76	20	16.65

Table 5: Lubricant refill capacities

### S-O-S Information

S O S Services is a highly recommended process for Caterpillar customers to use in order to minimize owning and operating cost. Customers provide oil samples, coolant samples, and other machine information. The dealer uses the data in order to provide the customer with recommendations for management of the equipment. In addition, S O S Services can help



determine the cause of an existing product problem. Refer to Caterpillar Special Publication, SEBU6250, “Caterpillar Machine Fluid Recommendations” for detailed information concerning S O S Services.

Refer to the Operation and Maintenance Manual, “Maintenance Interval Schedule” for a specific sampling location and a service hour maintenance interval.

Consult your dealer for complete information and assistance in establishing an S-O-S program for your equipment.

### **Maintenance Interval Schedule (MIS)**

Ensure that all safety information, warnings, and instructions are read and understood before any operation or any maintenance procedures are performed. The user is responsible for the performance of maintenance, including all adjustments, the use of proper lubricants, fluids, filters, and the replacement of components due to normal wear and aging. Failure to adhere to proper maintenance intervals and procedures may result in diminished performance of the product and/or accelerated wear of components. Use mileage, fuel consumption, service hours, or calendar time, WHICH EVER OCCURS FIRST, in order to determine the maintenance intervals. Products that operate in severe operating conditions may require more frequent maintenance.

### **Service Intervals**

**Note: Before each consecutive interval is performed, all maintenance from the previous interval must be performed. Perform the following servicing at EVERY interval they occur; for example, the 10 hour and 50 hour service are also performed at the 200 hour interval, etc.**

### **When Required**

- Boom Line – Install
- Hook Load Line – Install

#### **Every 10 Service Hours or Daily**

- Controls for proper operation of boom and hook– Check
- Boom Stop operation – Check, adjust if required
- Boom Pivot Pins – Lubricate
- Counterweight Cylinder Bearings – Lubricate
- Counterweight Hinge Pins – Lubricate
- Fairlead Sheave – Lubricate
- Hook and Wire Cable (Boom and Hook lines) – Inspect
- Hydraulic System Oil Level – Check
- Hoses and fittings for leaks – Check
- Sheave Block Bearings – Lubricate
- Pipelayer structures and components for loose bolts, cracks, damage, etc. – Inspect
- Inspect the hook for any distortion, bends, twists, etc. Inspect the hook for any wear, cracks, nicks, or gouges. Refer to American National Standard Institute ANSI/ASME B30.14
- Blocks, and yokes for wear or damage – Inspect
- Ensure that area between tractor tracks and pipelayer-tractor attachment structures are free from dirt, debris, ice, snow, etc. – Inspect

#### **Every 50 Service Hours or Weekly**

- Thoroughly check Boom Stop system operation and adjustment, lubricate boom stop valve roller and actuator.
- Lightly lubricate wire rope with recommended engine or hydraulic oil.

### 200 Hours Service Interval or Monthly

- Check oil level on gear box.

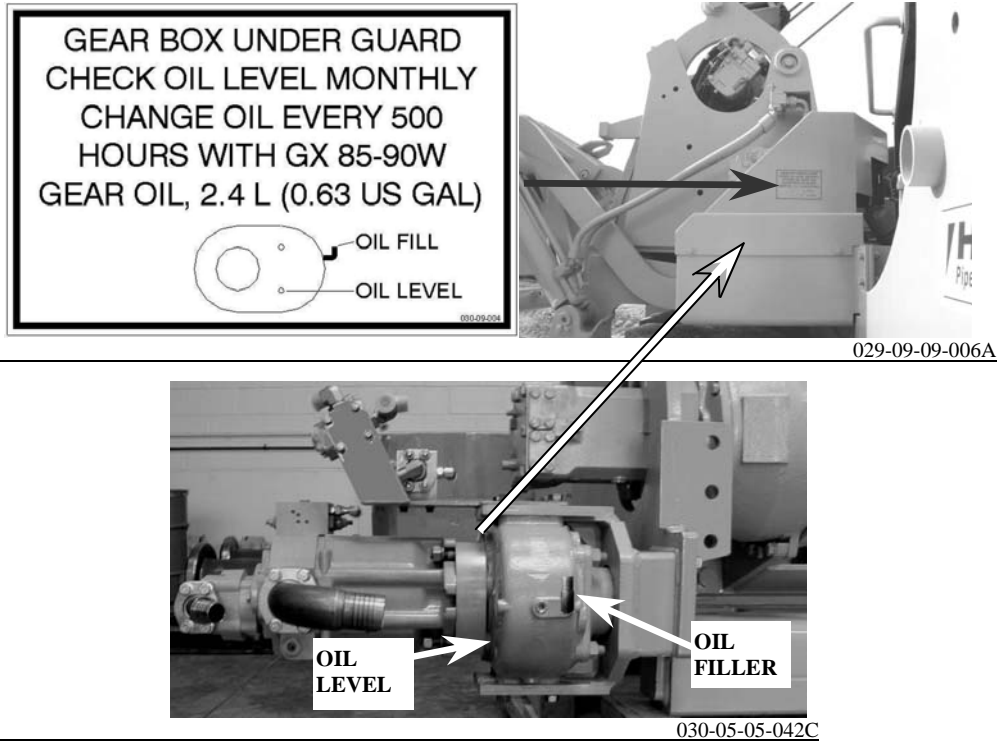

Figure 27: Gear Box.

### Every 500 Service Hours

- Hydraulic System Oil Sample - Obtain
- Change gear box oil (SAE 80W90)

### Every 500 Service Hours or 3 Months

- Main Return Filter – Replace
- Flushing Filter – Replace
- Circulating Oil Filter - Replace

### Every 2000 Service Hours or 1 Year

- Hydraulic System Oil - Change

## Accumulator charging



*This system contains high pressure gas. Failure to follow the instructions and warnings could cause an explosion, resulting in possible injury or death. Do not expose to fire. Do not weld. Do not drill. Do not remove any hydraulic system lines, taps or parts until pressure has been relieved. Relieve pressure before discharging. See Operation and Maintenance Manual "Accumulator - Relieving Charge". See Operation and Maintenance Manual "Accumulator" for charging and discharging. See your Dealer for tools and detailed information.*

Accumulator must be charged with dry nitrogen (N<sub>2</sub>) gas **by qualified personnel only**. The accumulator must be at the same temperature as the surrounding air before being checked or charged. Charge the accumulator depending on the ambient air temperature according to the table below.

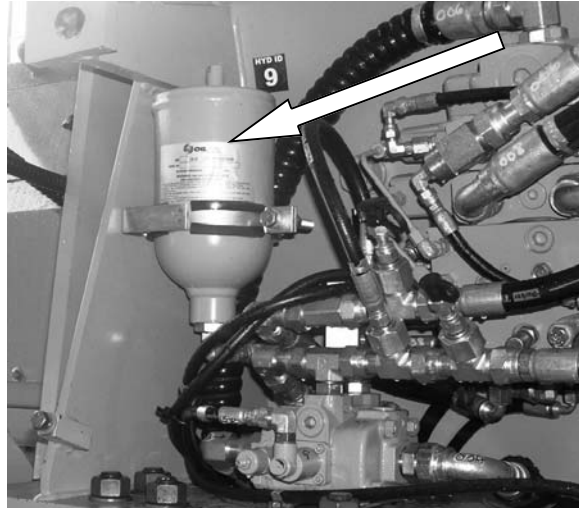

041-05-09-015

Figure 28: Accumulator located behind of the winch drawworks, between counterweight assembly and the drawworks.

Ambient air temperature [°C (°F)]	Accumulator precharge pressure [kPa (psi)] ± 70 kPa (10 psi)
-7°C (20°F)	3100 kPa (450 psi)
-1°C (30°F)	3170 kPa (460 psi)
4°C (40°F)	3240 kPa (470 psi)
10°C (50°F)	3310 kPa (480 psi)
16°C (60°F)	3375 kPa (490 psi)
21°C (70°F)	3445 kPa (500 psi)
27°C (80°F)	3515 kPa (510 psi)
32°C (90°F)	3580 kPa (520 psi)
38°C (100°F)	3650 kPa (530 psi)
43°C (110°F)	3720 kPa (540 psi)
49°C (120°F)	3790 kPa (550 psi)

Table 6: Accumulator precharge pressure for ambient air temperature

## Boom Stop Valve Operation and Adjustment

### **! WARNING**

*The Boom Stop system stops the boom winch from hauling-in when the boom is vertical, preventing overloading of key machine components. Incorrectly adjusting, or defeating the Boom Stop valve could result in serious equipment damage, personal injury, or even death. Its operation must be checked and verified daily.*

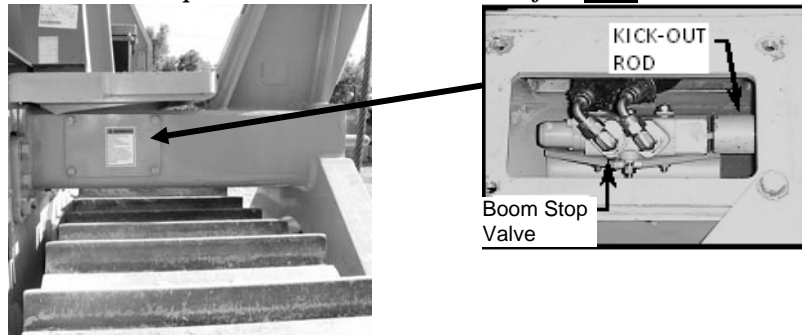

041-09-15-001

Figure 29: Boom Stop valve located behind access cover in Left Hand tower.

- To check the operation, boom in slowly taking care not to over tension the boom lines when the boom goes vertical. When the boom is vertical, the boom winch should stop. No increase in tension should occur once the boom comes into contact with the left hand tower. If the boom winch does not stop and continues to increase the cable tension, STOP the operation at once and lower the boom to release the tension. Adjust the Boom Stop valve as set out below.
- Raise the boom vertical so that it is **JUST** in contact with the tower; the boom kick-out rod is fully retracted into the tower. Do not over tighten the lines to the point that the boom or structures are overly stressed.
- Remove the boom stop valve access panel from the tower.
- Loosen the boom stop valve nuts.
- Move the valve so that it just contacts the boom kick-out rod.
- Move the valve an additional 9.5 mm (3/8-in) towards the boom so that the valve's piston is fully depressed.
- Tighten the valve in position with the valve nuts.
- Test the boom stop valve to see that it works properly. Lower the boom until the boom stop valve piston is free from the kick-out rod.
- Replace the boom stop valve access panel from the tower.
- Boom in slowly taking care not to over tension the boom lines when the boom goes vertical. When the boom is vertical, the kick-out rod will move the boom stop valve piston in 9.5 mm (3/8 in), and the boom winch should stop with the boom vertical. No increase in tension should occur once the boom comes into contact with the left hand tower, readjust the boom stop valve as required.

## Boom Line – Install

### **! WARNING**

*Do not operate or work on this equipment unless you have read and understand the instructions and warnings in the Operation and Maintenance Manual. Failure to follow the instructions or heed the warnings could result in injury or death. Contact your dealer or Vanguard Equipment or visit our website at [vanguardequip.com](http://vanguardequip.com) for replacement manuals. Proper care is your responsibility.*

### **! WARNING**

*Personal injury or death can result from worn wire rope cable. Worn or frayed cable could break causing injury. Check the wire rope cable. If cable is worn or is frayed install new cable. Wear gloves when handling the wire rope cable. Proper care is your responsibility.*

---

#### NOTICE

Make sure that the construction of the wire rope is 6x25 IWRC XIPS (Independent Wire Rope Core, eXtra Improved Plow Steel) USA MADE. Also, the established grade of the wire rope is the improved plow bolt (steel), 26670 kg (58 800 lb) minimum breaking strength.

SPECIFICATIONS (WIRE ROPE)		
Boom Line Cable		
Boom Length	Diameter of Cable	Length of Cable
6.1 m (20 ft)	19.05 mm (0.75 inch)	40.2 m (132 ft)
7.3 m (24 ft)	19.05 mm (0.75 inch)	45.7 m (150 ft)

Table 7: Boom line wire rope specifications

1. Lower the boom to the ground and support the boom.

**Note: The loaded force in the winch drum must be neutralized before removing the wire rope from a loaded drum.**

2. Remove the anchor for the wire rope from the drum for the boom. Remove the old wire rope.
3. Unroll the new wire rope from the spool.

**Note:** Weld the cable ends in order to prevent fraying.

#### NOTICE

Unroll all of the cable from the spool. Lay the wire rope on a flat surface. Never lift the wire rope off the spool in coils.

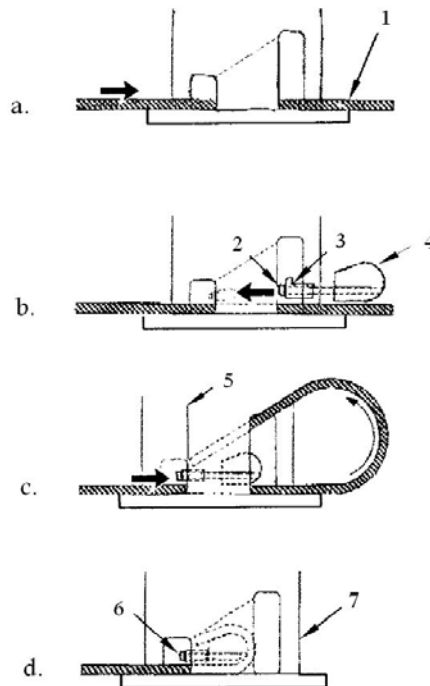

Figure 30: Installing boom line, cable anchor assembly on winch drum

4. Install boom line onto drum
  - a. Install the cable (1) into the small slot and through the larger slot in the drum for the boom..
  - b. Make sure that 2 to 4 threads of cap screw (2) are engaged into the cable anchor assembly (4). Start with the cap screw and insert the cable anchor assembly into the longer slot as far as allowed.
  - c. Make sure that the lip of retainer (3) faces the top edge (5) of the small slot in order to hold the retainer in place. Make a loop with the end of the wire rope and insert the end into the slot past the cable anchor assembly.
  - d. Pull the wire rope until the wire rope and anchor assembly are securely seated inside the slot. Tighten the cap screw (6) to a torque of  $44 \pm 3 \text{ N}\cdot\text{m}$  ( $32 \pm 2 \text{ lb ft}$ ).

5. Wind one half of the wire rope on the drum (7.) Wind the wire rope evenly across the drum.



Figure 31: Installing wire rope on machine

041-05-30-006A

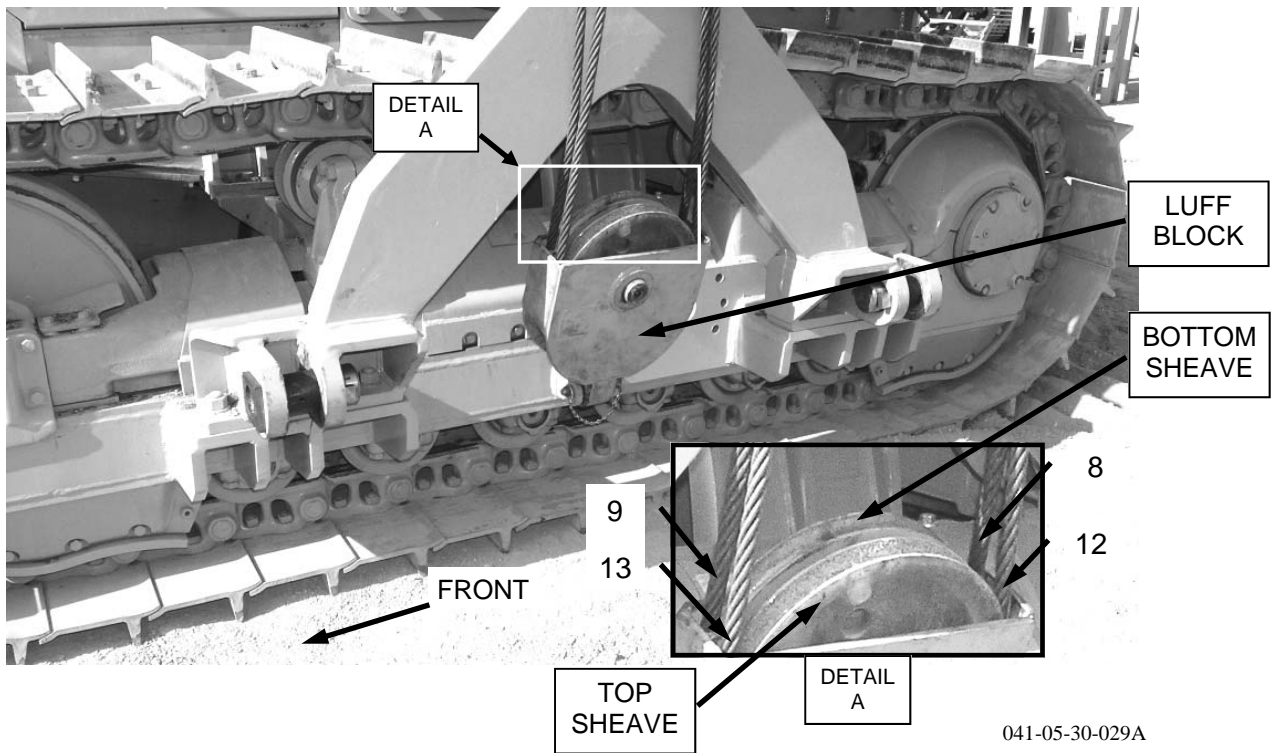
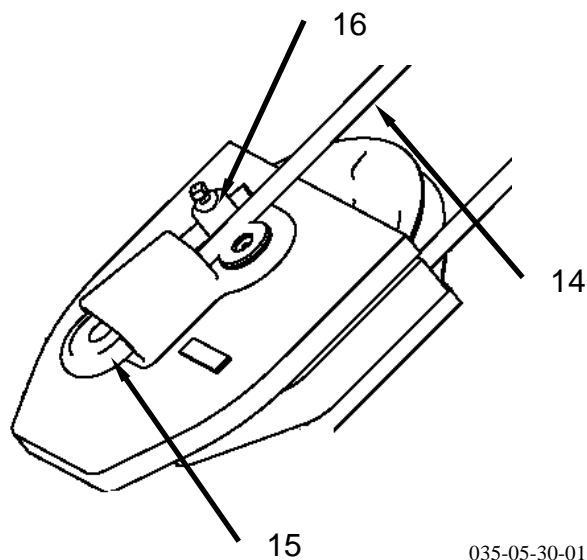

Figure 32: Installing wire rope on machine

041-05-30-029A

6. Install boom line on machine as follows:
  - a. Cable starts off top of boom drum (7).
  - b. Through rear of bottom sheave on luff block (8).
  - c. Out front of bottom sheave on luff block (9).
  - d. Through front of tail block sheave (10)
  - e. Out rear of tail block sheave (11).
  - f. Through rear of top sheave on luff block (12).
  - g. Out front of top sheave on luff block (13).
  - h. To cable anchor on tail block (14).



035-05-30-015A

Figure 33: Installing boom line in tail block

7. Install boom line in tail block
  - a. Insert the wire rope into the pocket and around the wedge (15). Allow an additional length of cable to form a tail end (six inch minimum). Use a mallet to tap the wedge and the wire rope into the pocket.
  - b. Insert the tail end of the wire rope through clamp (16). Add a short piece of wire rope through clamp (16) in order to secure the clamp, as needed. Tighten the nuts on the clamp.
  - c. **Note:** Do not clamp the loaded end of the wire rope and the tail end of the wire rope together.
  - d. Apply the first load in order to seat wedge (15).

## Boom Pivot Pins – Lubricate

The grease fittings for lubricating the boom pivot pins are located on the left side of the machine.

There is one grease fitting for each pin. The grease fittings are located on the end of the pin on the outside face of the boom.



041-05-30-029

Figure 34: Boom pivot pins, grease fittings

Lubricate the boom pivot pins through the two fittings.

## Counterweight Cylinder Bearings – Lubricate



041-05-68-032

Figure 35: Counterweight cylinder bearings fittings location

There are two grease fittings for each of the two counterweight cylinders.

1. Extend the counterweight.
2. Move the speed/lockout control lock lever to the locked position; refer to the Operation and Maintenance Manual, "Speed/Lockout Control Lever".
3. Lubricate the lower grease fitting that is located in the head end of the cylinder.
4. Lubricate the upper grease fitting that is located in the rod end of the cylinder.
5. Move the speed/lockout control lock lever to the desired speed position—refer to the Operation and Maintenance Manual, "Speed/Lockout Control Lever"—and retract the counterweight.



## Counterweight Hinge Pins - Lubricate

# **WARNING**

*Use a stable work platform placed in a secure location when lubricating the counterweight hinge pins. If a secure location is not available, use the appropriate safety equipment to prevent falling off of the machine. Failure to work from a secure location may result in injury or death from a slip or a fall.*

1. Extend the counterweight.
2. Move the speed/lockout control lock lever to the locked position; refer to the Operation and Maintenance Manual, "Speed/Lockout Control Lever".
3. Lubricate the six pins through the grease fittings. There are three grease fittings that face toward the front of the machine and there are three grease fittings that face toward the rear of the machine.

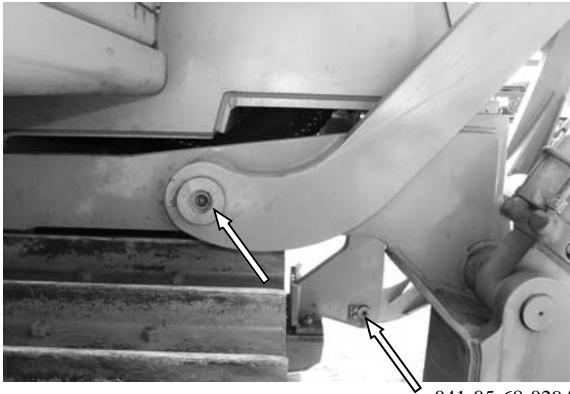
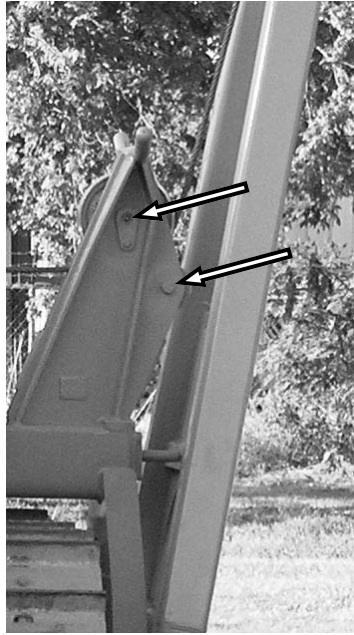

Figure 36: Counterweight hinge pins located right side of machine lubrication points

4. Lubricate the two lower pins through the grease fittings and the two upper pins.

## Fairlead Sheave – Lubricate



041-05-05-064A

Figure 37: Fairlead sheave lubrication points

Lubricate one fitting in the lower sheave and lubricate one fitting in the upper pin.

## Hook and Wire Cable – Inspect

### Inspect the Hook

Inspect the hook frequently. The inspections should include observation of the hook during operation of the hook. A designated person determines if the conditions that are found during the inspections constitute a hazard. The designated person will determine if a more detailed inspection is required.

- Inspect the hook for any distortion such as bends in the hook or twists in the hook.
- Inspect the hook for any wear.
- Inspect the hook for cracks, nicks, or gouges.
- If a latch is provided, inspect the latch. Make sure that the latch engages properly. Inspect the latch for any damage. Make sure that the latch is not malfunctioning.
- Inspect the hook assembly and the means for securing the hook assembly.
- For additional information on the proper maintenance and on the proper inspection of hooks, refer to "American National Standard Institute ANSI/ASME B30.14".

### Inspect Wire Cable - Boom and Hook lines

Make a visual inspection of all running cables that are in continuous use. Make the inspection of the running cables on a daily basis before the machine is placed in operation. Inspect all of the cables on a monthly basis.

All inspections shall be performed by a designated person. Keep a dated report of the condition of the cable on file in a location that is available to designated personnel. Perform a close inspection of the sections of the cable that are normally hidden during the visual inspection and the maintenance inspection. (This includes the sections of the cable that pass over the sheaves.) These points are the sections of the cable that are most likely to fail.

Note any deterioration that results in a notable loss of the original strength. (See the conditions that are described below.) Determine if further use of the cable will constitute a hazard.

Inspect the cable on a daily basis for the following conditions:

- Inspect the cable for a reduction in the diameter of the cable below the nominal diameter. A loss of support in the cored wire of the cable may be caused by internal corrosion, external corrosion, or wear of the outside wires.

- Inspect the cable for broken outside wires. Check for the degree of distribution of the broken outside wires. Check for the concentration of outside broken wires.
- Inspect the cable for worn outside wires.
- Inspect the cable for corroded wires and for broken wires at the connection on the wire cable end.
- Inspect the cable end for connections that are corroded, cracked, bent, worn, or improperly installed.
- Inspect the cable for sections that are crushed or kinked and for any loose wire strands.

Excessive wear or broken wires may occur in sections of the cable that are in contact with saddles, equalizer sheaves, or other sheaves. Excessive wear or broken wires can also occur when cable travel is limited. Take care to inspect the ropes at these locations.

When a machine is shutdown for a month or more, inspect all of the cables thoroughly. When a side boom machine has been in storage for a month or more inspect all of the cables thoroughly. The inspection should be completed before the machine is returned to operation.

The inspection should be for all types of deterioration. The inspection should be performed by a designated person or by an authorized person. The authorized person's approval is required for further use of the cable.

A dated report on the condition of the cable should be kept on file.

Take care in the inspection of cable that is resistant to rotation.

Any new poured socket or swaged socket assembly that is used as a standing cable (guy) shall be proof tested. Test the cable to the lift capacity of the side boom machine or to the manufacturer's recommendation.

Never give the cable a rating that is greater than 50 percent of the wire rope's nominal strength or of the structural strand's nominal strength.

**Note:** For additional information on the proper maintenance and on inspection of the cable, refer to "American National Standards Institute ANSI/ASME B30.14".

### Hook Load Line – Install



*Do not operate or work on this equipment unless you have read and understand the instructions and warnings in the Operation and Maintenance Manual. Failure to follow the instructions or heed the warnings could result in injury or death. Proper care is your responsibility.*



*Personal injury or death can result from worn wire rope cable. Worn or frayed cable could break causing injury. Check the wire rope cable. If cable is worn or is frayed install new cable. Wear gloves when handling the wire rope cable.*

---

#### NOTICE

Make sure that the construction of the wire rope is 6x25 IWRC XIPS (Independent Wire Rope Core, eXtra Improved Plow Steel) USA MADE. Also, the established grade of the wire rope is the improved plow bolt (steel), 26670 kg (58 800 lb) minimum breaking strength.

---

SPECIFICATIONS (WIRE ROPE) Hook Load Line Cable		
Boom Length	Diameter	Length
6.1 m (20 ft)	19.05 mm (0.75 inch)	50.3 m (165 ft)
7.3 m (24 ft)	19.05 mm (0.75 inch)	57.3 m (188 ft)

Table 8: Hook load line wire rope specifications

1. Lower the boom to the horizontal position.
2. Remove the anchor for the wire rope from the drum for the hook. Remove the old wire rope.
3. Unroll the new wire rope from the spool.

**Note:** Weld the cable ends in order to prevent fraying.

---

**NOTICE**

Unroll all of the cable from the spool. Lay the wire rope on a flat surface. Never lift the wire rope off the spool in coils.

---

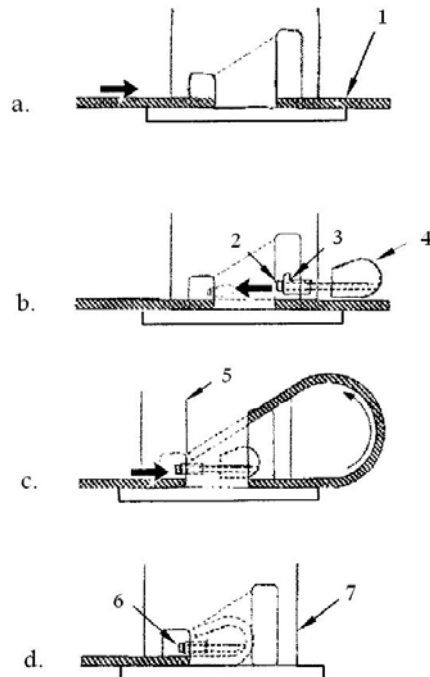

**Figure 38: Installing hook load line, cable anchor assembly**

1. Install hook load line, cable anchor assembly.
  - a. Install the cable (1) into the small slot and through the larger slot in the drum for the hook load line.
  - b. Make sure that 2 to 4 threads of capscrew (2) are engaged into the cable anchor assembly (4). Start with the capscrew and insert the cable anchor assembly into the longer slot as far as allowed.
  - c. Make sure that the lip of retainer (3) faces the top edge (5) of the small slot in order to hold the retainer in place. Make a loop with the cable end and insert the cable end into the slot past the cable anchor assembly.
  - d. Pull the cable until the cable and anchor assembly are securely seated inside the slot. Tighten the capscrew (6) to a torque of  $44 \pm 3$  Nm ( $32 \pm 2$  lb ft).
  - e.
2. Wind one half of the cable evenly across the load drum (7).

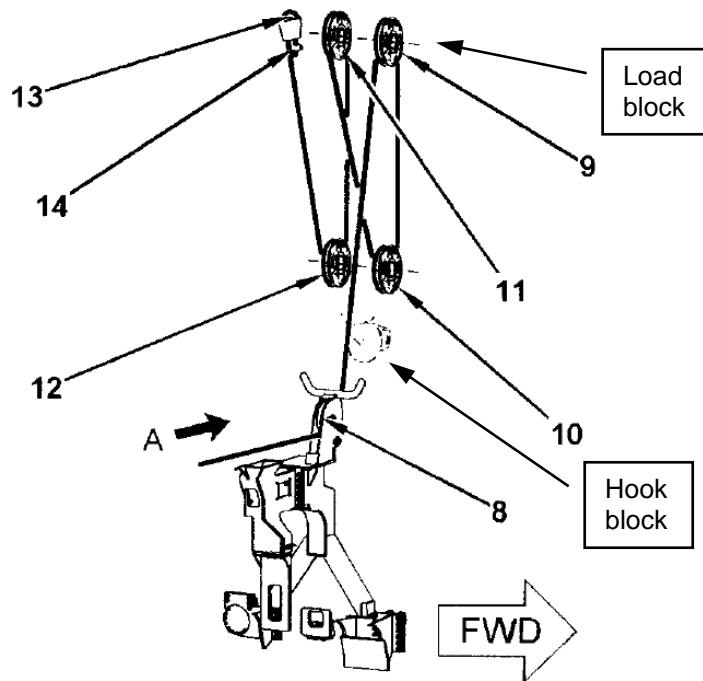

Figure 39: Installing hook load line

(A) Wire rope from the winch.

3. Install the hook load line from the winch drum onto the sheave blocks in the following manner:

- a. Install the cable for the hook winch from the winch drum to fairlead sheave (8).

**Note:** The cable for the hook winch should go over upper sheave (9) which is toward the front of the machine. Anchor the cable for the hook winch toward the rear of the machine, ie., make sure the block anchor faces toward the rear of the machine.

- b. Install the cable over upper sheave (9).
- c. Install the cable under lower sheave (10).
- d. Install the cable over upper sheave (11).
- e. Install the cable under lower sheave (12).
- f. Insert the cable into the pocket and around wedge (13). Allow an additional length of cable to form a tail end (six inch minimum). Use a mallet to tap the wedge and the wire rope into the pocket.
- g. Insert the tail end of the wire rope through clamp (14). Add a short piece of wire rope through clamp (14) in order to secure the clamp, as needed. Tighten the nuts on the clamp.
- h. Pull the cable until the line is tight in order to seat wedge (13). Lift the lower block above the ground.
- i. Raise the boom.

## Hydraulic System Oil - Change

Refer to the specific tractor Operation and Maintenance Manual "Hydraulic System Oil - Change" for complete requirements and procedures.

### **⚠ WARNING**

*At operating temperature, the hydraulic tank is hot and under pressure. Hot oil and components can cause personal injury. Do not allow hot oil or components to contact skin. Remove the filler cap only when the engine is stopped, and the filler cap is cool enough to touch with your bare hand. Remove the filler cap slowly in order to relieve pressure.*

---

#### NOTICE

Care must be taken to ensure that fluids are contained during performance of inspection, maintenance, testing, adjusting and repair of the product. Be prepared to collect the fluid with suitable containers before opening any compartment or disassembling any component containing fluids.

Dispose of all fluids according to local regulations and mandates.

---

Operate the machine in order to warm the oil.

Park the machine on level ground. Engage the parking brake and stop the engine.



Figure 40: Hydraulic tank filler cap

Remove the hydraulic tank filler cap (1) slowly in order to relieve any pressure.

1. Wash the filler strainer and the filler cap in a clean nonflammable solvent.
2. Remove oil drain plug (2).
3. Attach a hose to a 1 inch NPT pipe nipple. This 1 inch NPT pipe nipple should have a length of 100 mm (4 inch).
4. Install the pipe nipple into the drain plug opening.
5. Rotate the pipe nipple clockwise in order to open the internal drain valve. Allow the oil to drain into a suitable container.
6. Remove the pipe nipple. The valve for the hydraulic tank will close.
7. Clean drain plug (2) and install drain plug (2). Tighten drain plug (2) to a torque of  $68 \pm 7$  Nm ( $50 \pm 5$  lb ft).
8. Install the filler strainer and tank filler cap (1).

9. See the Operation and Maintenance Manual, “Capacities (Refill) in order to determine the amount of hydraulic oil that is needed to fill the hydraulic oil tank. Fill the hydraulic oil tank.
10. Inspect the filler cap (1) gasket. Install a new gasket if damage or wear is evident. Install the filler cap.
11. Start the engine. Run the engine for a few minutes. Check for leaks.
12. Maintain the oil level to the “FULL” mark in sight gauge (3). Add oil, if necessary. Stop the engine.

## Hydraulic System Oil Filter - Replace



*At operating temperature, the hydraulic tank is hot and under pressure. Hot oil and components can cause personal injury. Do not allow hot oil or components to contact skin. Remove the filler cap only when the engine is stopped, and the filler cap is cool enough to touch with your bare hand. Remove the filler cap slowly in order to relieve pressure.*

1. Slowly remove the hydraulic tank filler cap in order to relieve the system pressure.
2. Unbolt the access door that is located on the right side of the machine to the right of the site gauge.



041-05-09-018A

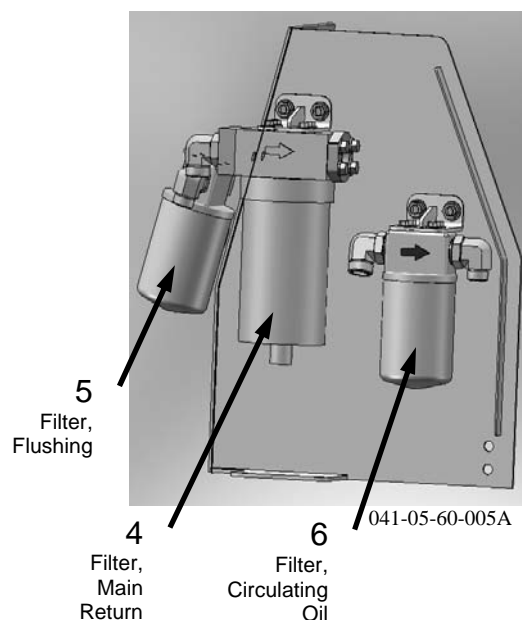

Figure 41: Filler location

- (4) Main return filter
- (5) Flushing filter
- (6) Circulating oil filter

3. Remove filters (4, 5, and 6)

**Note:** Remove circulating oil filter (6). Discard the used filter. Filter (6) must be removed for access to hydraulic system filter (4). Replace both of the filters at the same time. Remove the access door, beside the seat, on the right side of operator console to replace flushing filter (5).

4. Inspect the seal on the filter housings for flushing filter (4, 5, and 6). If the seals are damaged or worn, install new seals. Install a new filter element into the filter housing for (4, 5, and 6).

## Hydraulic System Oil Level – Check

### **! WARNING**

*At operating temperature, the hydraulic tank is hot and under pressure. Hot oil and components can cause personal injury. Do not allow hot oil or components to contact skin. Remove the filler cap only when the engine is stopped, and the filler cap is cool enough to touch with your bare hand. Remove the filler cap slowly in order to relieve pressure.*

The hydraulic tank is on the right rear corner of the machine.

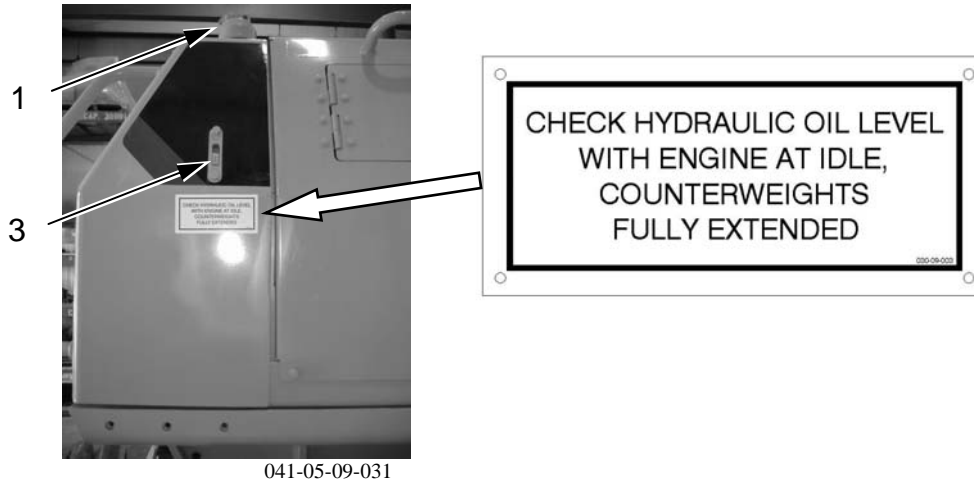

Figure 42: Hydraulic Tank

1. The counterweight should be fully retracted when you check the oil level.
2. Maintain the oil level to the “FULL” mark in sight gauge (3).
3. If the hydraulic system requires additional hydraulic oil, remove filler cap (1) and add oil. Clean filler cap (1) and install filler cap (1).

## Hydraulic System Oil Sampling

Refer to the tractor's operation and maintenance manual for the specific procedures regarding Hydraulic System Sampling.

## Oil Filter Inspection

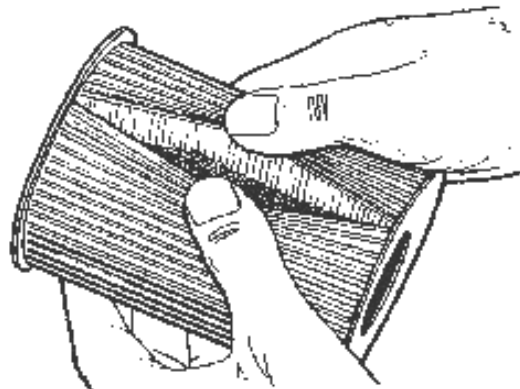

Figure 43: Oil filter.

Use a Filter Cutter - CAT# 4C-5084, or similar to cut the filter element open. Spread apart the pleats and inspect the element for metal and other debris. An excessive amount of debris in the filter element can indicate a possible failure.



If metals are found in the filter element, a magnet can be used to differentiate between ferrous metals and nonferrous metals. Ferrous metals would indicate wear on steel parts and on cast iron parts. Non ferrous metals would indicate wear of the brass or aluminum part of the hydraulics such as main bearings, pump sleeves, etc.

Small amounts of debris may be found in the filter element. This could be caused by friction and normal wear. Consult your Caterpillar dealer in order to arrange for further analysis if an excessive amount of debris is found.

Using an oil filter element that is not recommended by Caterpillar could result in severe damage. This could result in larger particles in unfiltered oil. These particles could enter the system and cause damage.

### Sheave Block Bearing – Lubricate

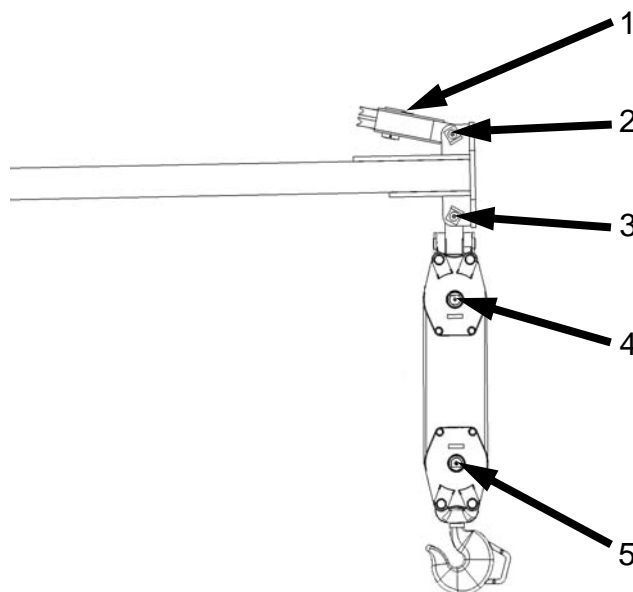

035-20-30-007B

Figure 44: Rigging Grease Nipples

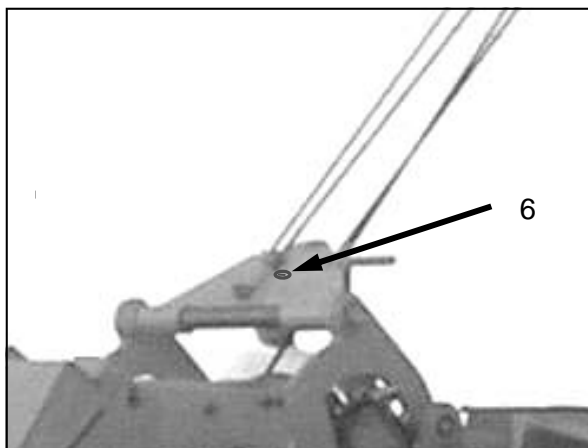

Figure 45: Rigging Grease Nipples - Tail Block

041-05-05-60A

1. Lubricate (1) in the luff block.
2. Lubricate fitting in the pins for boom luff block (2 & 3) and load sheave block.
3. Lubricate pin (4) in load sheave block and the pin (5) in the hook sheave block.
4. Lubricate pin (6) on tail block.

### Tractor Maintenance

Refer to the tractor's operation and maintenance manual for the specific procedures regarding complete Tractor Maintenance.