

Operation and Maintenance Manual

Pipelayer attachment for D4H LGP, D5M LGP, and D5N LGP

S/N D4H0038 – UP (Sideboom)
S/N D5M0021 –UP (Sideboom)
S/N D5N0021 –UP (Sideboom)

**TO BE USED WITH CATERPILLAR
D4H, D5M, AND D5N TRACTOR OPERATION AND MAINTENANCE MANUALS**

**VANGUARD EQUIPMENT, INC.
15627 EAST PINE ST
TULSA, OKLAHOMA
74116, USA**

 **: 918.437.1796**

 **: 918.437.1794**

Table of Contents

FOREWORD	1
MACHINE DESCRIPTION	1
SAFETY	1
WARNING SIGNS AND LABELS.....	1
GENERAL HAZARD INFORMATION.....	1
MOUNTING AND DISMOUNTING.....	1
<i>Alternate Exit (Cab models only)</i>	2
<i>Operating with Cab Doors Open</i>	3
SWITCH TO DOZER MODE WHEN DOZING	3
LIFTING CAPACITY	4
<i>D4H LIFT CHART</i>	5
<i>D5M LIFT CHART</i>	5
<i>D5N LIFT CHART</i>	6
ELECTRIC POWER LINES.....	6
<i>Minimum Distances</i>	6
WIRE ROPE.....	7
COLLISION AVOIDANCE	7
PINCH POINTS.....	7
FOLDING BOOM LOCK-PINS	7
HAND SIGNALS.....	7
MACHINE PARKING	8
HIGH HYDRAULIC SYSTEM PRESSURE.....	8
ELECTRICAL STORM INJURY PREVENTION	9
COMPONENTS AND SPECIFICATIONS	9
LOCKOUT CYLINDERS	10
DRAW WORKS CONTROLS.....	11
MODE CONTROL LEVER	11
<i>Limited Dozer Functions</i>	11
HOOK CONTROL LEVER	12
BOOM CONTROL LEVER	13
BOOM STOP VALVE.....	14
FOLDING BOOM.....	15
EXTENDING	15
STOWING.....	16
BOOM REMOVAL AND INSTALLATION (FOLDING AND RIGID BOOMS)	19
MAINTENANCE AND LUBRICATION.....	19
GENERAL.....	19
LUBRICANT VISCOSITIES	19
REFILL CAPACITIES	19
PIPELAYER SERVICE INTERVALS	19
<i>Wire rope cable</i>	19
<i>Service Intervals</i>	20
<i>10 Hours Service Interval or Daily</i>	20
<i>50 Hours Service Interval or Weekly</i>	22
<i>200 Hours Service Interval or Monthly</i>	22
<i>500 Hours Service Interval or 3 Months</i>	23
<i>2000 Hours Service Interval or 1 Year</i>	23
WIRE ROPE.....	23
ACCUMULATOR	23
BOOM STOP VALVE ADJUSTMENT.....	23
AIR CONDITIONER FILTER ACCESS (CAB MODELS ONLY).....	23
WINCH TRAIN OIL CHANGE	24
RIGGING.....	24
WIRE ROPE SPECIFICATIONS	24
<i>18 ft Folding Boom</i>	24
<i>20 ft Rigid Boom</i>	24

LOAD WINCH LINE INSTALLATION.....	24
BOOM WINCH LINE INSTALLATION.....	25
APPENDIX: RIGGING ANCHOR PROCEDURES.....	26

Foreword

Machine Description

The side boom equipment is attached to a Caterpillar D4H LGP, D5M LGP, or D5N LGP tractor. The primary use of this machine is for petroleum-product pipeline-construction, urban and residential water and gas line installation, and medium duty bulldozing.

The operator should read, understand, and follow both the tractor and pipelayer operating and maintenance instructions. The operator must comply with all pipelayer procedures, regulations, and safety precautions.

The daily service/inspection procedure should be performed before start-up.

Operate all pipelayer controls with no load, until familiar with machine operation.

Note: Refer to the Caterpillar operation manual for detailed information on the specific operation of the tractor unit.

Safety

Certain conditions and precautions are peculiar to pipelaying operations. The following represents the minimum considerations for safe operations.

Warning Signs and Labels

Make sure that all of the warning signs are legible. Clean or replace the warning signs if you cannot read the words. Replace the illustrations if the illustrations are not visible. Use a cloth, water and mild soap to clean the warning signs. Do not use solvent, gasoline, or other harsh chemicals to clean the warning signs. Do not use pressure washers to clean the warning signs.

Replace any warning sign that is damaged, or missing. If a warning sign is attached to a part that is replaced, install a warning sign on the replacement part.

General Hazard Information

To prevent cable from slipping off the drum, a minimum of five full-wraps of cable must remain on the winch drum at maximum working extension of the hook or boom.



Mounting and Dismounting

Do not attempt to mount or dismount the machine between the machine and any object that may move.

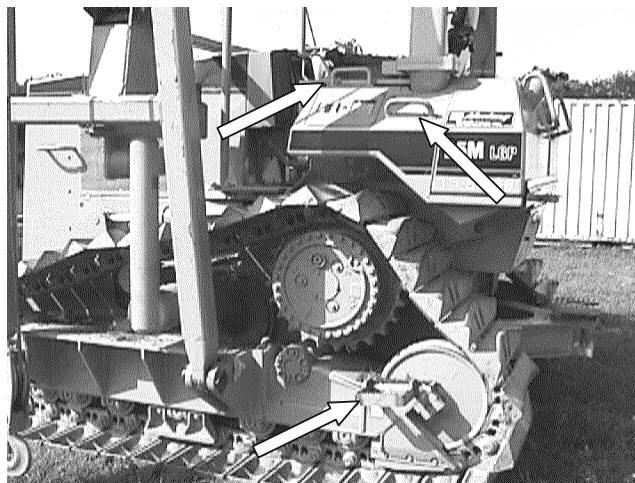

Figure 1: Canopy access.



Figure 2: Cab access.

Get on the machine only at locations that have steps and/or handholds. Get off the machine only at locations that have steps and/or handholds. Before getting on the machine, clean the steps and handholds. Inspect the steps and handholds. Make all necessary repairs.

Face the machine whenever getting on or off the machine. Maintain three-point contact with the steps and with the handholds.

Note: Three-point contact can be two feet and one hand. Three-point contact can also be one foot and two hands.

Do not get onto or off a moving machine. Never jump off the machine. Do not try to get onto or off the machine while carrying tools or supplies. Use a hand line to pull equipment onto the platform. Do not use any controls as handholds when entering or exiting the operator compartment.

Ground personnel must be kept clear at all times and only approach the machine when signaled to do so by the operator.

Alternate Exit (Cab models only)

In machines that are equipped with cabs, the rear window serves as an alternate exit. To remove the rear window, pull the ring and push out the glass.

Remove the O-ring seal from the glass support seal. This will provide enough clearance so that the seal can hinge. Now the glass can pass outward.

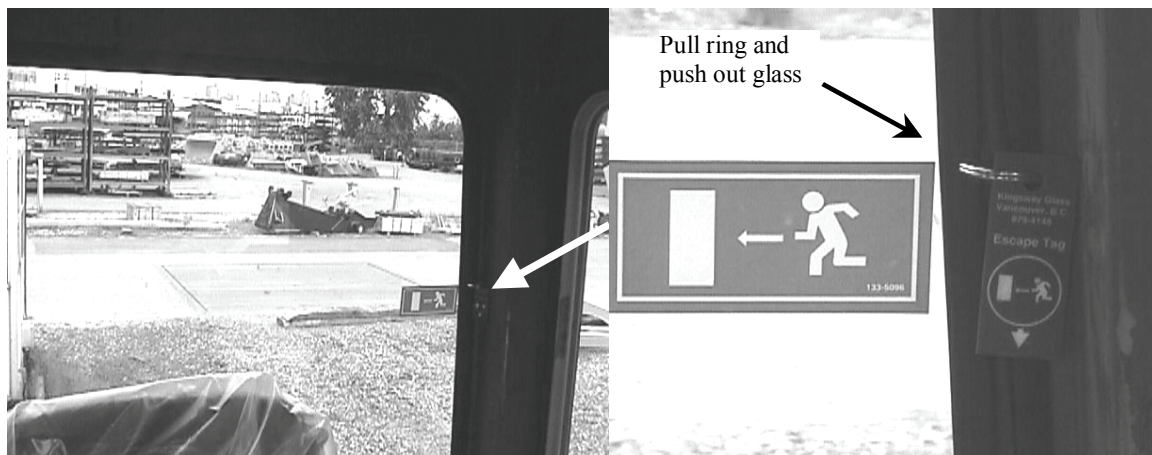

Figure 3: Alternate exit.

032-08OP-007C

S/N D4H0038 – UP
S/N D5M0021 – UP
S/N D5N0021 – UP

Operating with Cab Doors Open

When the pipelayer winches are in operation, the right side cab door must be kept closed. Failure to do so could cause damage to the right cab access door and possibly result in personal injury.



Figure 4: Cab door open operation Warning: Located on inside cab door.

Switch to Dozer Mode When Dozing

This machine is equipped with hydraulic cylinder-rams that automatically extend to lockout the tractor's equalizer bar in pipelayer mode, and automatically retract in dozing mode. The blade remains active while in pipelayer mode, with its operational speed reduced, to allow it to be moved to clear obstacles or to improve vision. **NO DOZING SHOULD BE DONE IN PIPELAYER MODE, SWITCH TO DOZER MODE WHEN DOZING.** Dozing in pipelayer mode—with the lockout cylinders extended—will damage the cylinders to the point where they will no longer provide adequate support for the sideboom during lifting. The suspended load may shift unexpectedly causing injury or death to personnel working around it; the entire sideboom may unexpectedly tip, resulting in personal injury or death. Before switching to dozer mode, lower any suspended load to the ground. **NO LOAD IS TO BE SUPPORTED OR CARRIED BY THE SIDE BOOM IN DOZER MODE.** Refer to the sections on Lockout Cylinders and on Draw Works Controls in this manual for operating procedures.

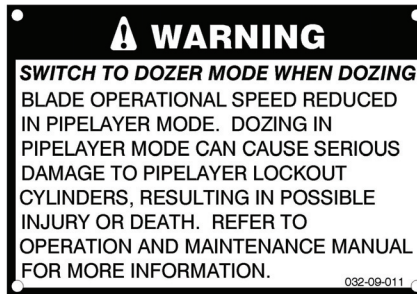

Figure 5: Mode Control Position Warning: Located by dozer-blade control.

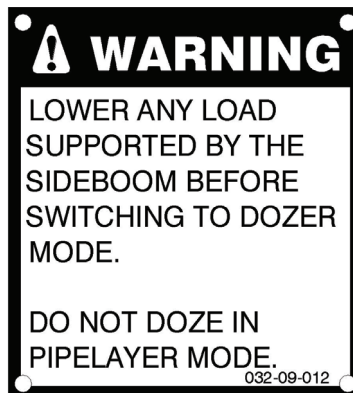

Figure 6: Lower Loads Before Switching to Dozer Mode Warning: Located on winch control box.

Lifting Capacity

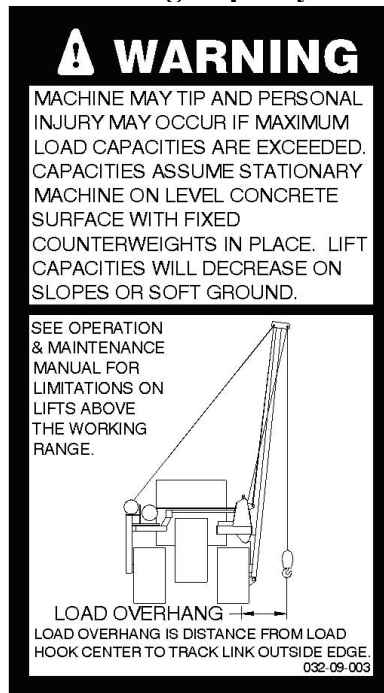

Figure 7: Tip warning decal; located on left side of machine, near operator seat.



The VEI pipelayer attachment lift capacity charts, shown below, were developed by VEI for standard equipment—unless specified otherwise—tractor models: D4H LGP with an LGP 4VPAT blade, D5M LGP with an LGP 5VPAT blade, and D5N LGP with an LGP 5VPAT blade with no additional attachments installed. Installation of additional equipment or other options may reduce the tipping characteristics of the machine below those given in the VEI chart.

Machine may tip and personal injury may occur, if maximum load capacities are exceeded. Capacities assume stationary machine on level concrete surface with fixed counterweights (if required) in place. Lift capacities will decrease on slopes or soft ground.

The units are rated for lifting capacities in accordance with SAE recommended practice SAE J743, and ANSI/ASME B30.14. Capacity ratings are established on a level concrete surface with fixed counterweights (if required) in place, the load hanging vertically from the hook and balanced by the weight of the pipelayer components.

No additional counterweight is required with the specified blades installed. Optional, additional counterweight is available to operate the unit with the blades removed.

Wire rope limitations, soil conditions, and slope of terrain reduce actual capacity. All lifts must be made with the load line vertical, and the boom centerline directed toward the load.

Except for test purposes, no side boom shall be loaded beyond the maximum load capacity. See the warning decal and lifting capacity chart located on the machine for maximum load capacity ratings. When exceeding the ratings, follow American National Standards ANSI B30.14-1979 Section 14.2. In addition, the following requirements must be met:

1. An inspection before and following the lift reveals no defects in the wire rope cable.
2. The maximum load capacity of the side boom is not exceeded.
3. The load must be handled in a manner and at speeds minimizing tipping effects.
4. The lift and inspections are made under controlled conditions under the direction of a competent person.

D4H LIFT CHART

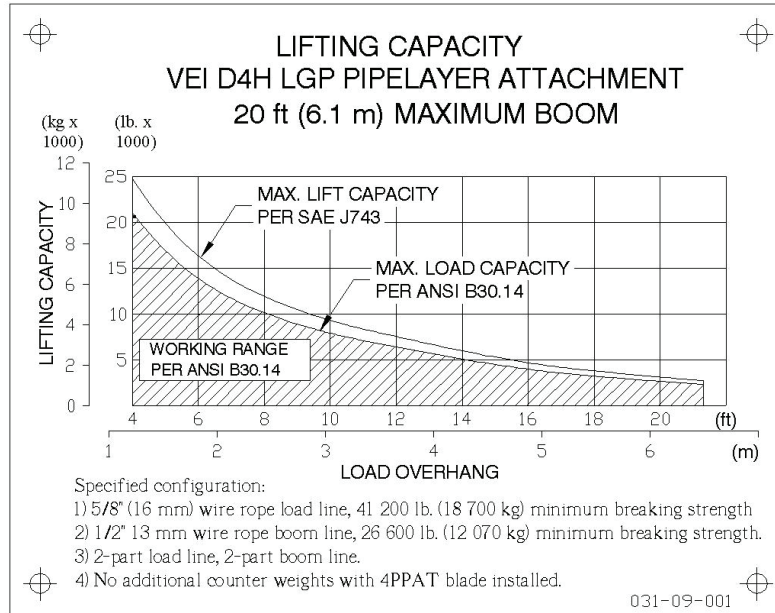

Figure 8: D4H LGP Lift capacity chart; located on left side of machine, near operator seat.

D5M LIFT CHART

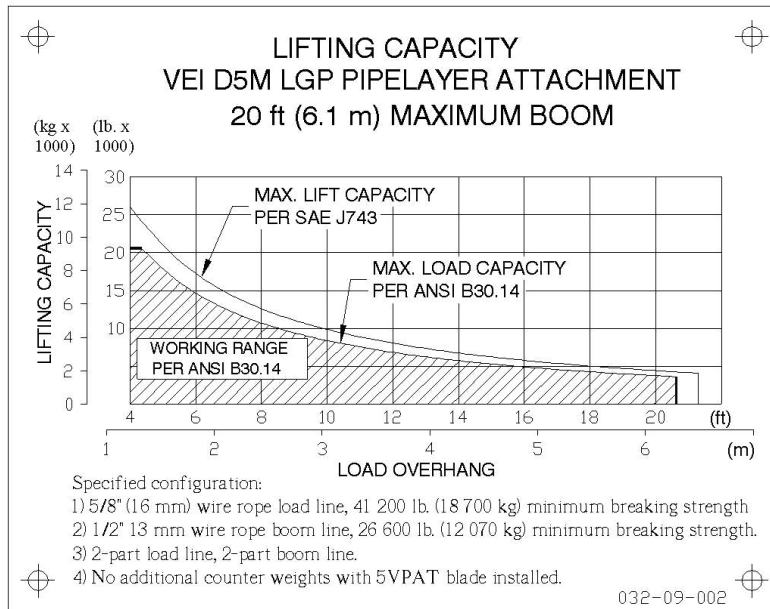

Figure 9: D5M LGP Lift capacity chart; located on left side of machine, near operator seat.

D5N LIFT CHART (MODIFIED – 24-IN Tack Shoe)

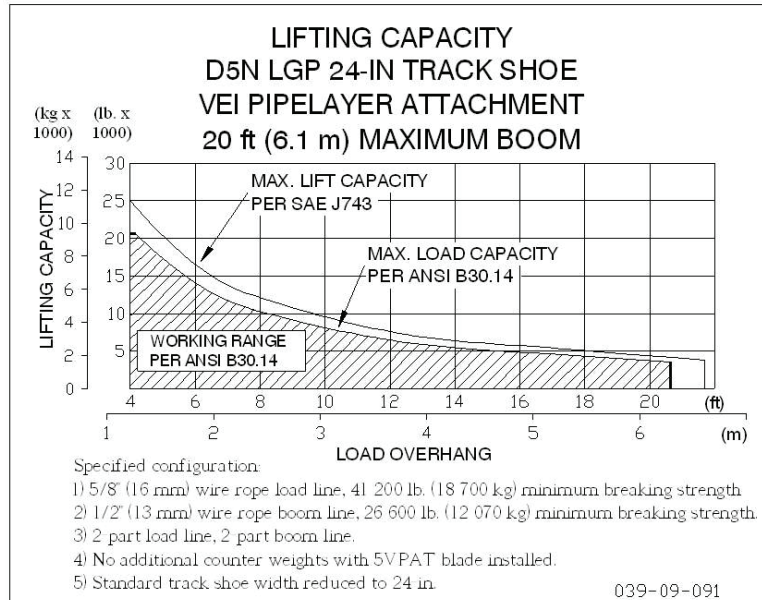

Figure 10: D5N LGP Lift capacity chart; located on left side of machine, near operator seat.

Electric Power Lines

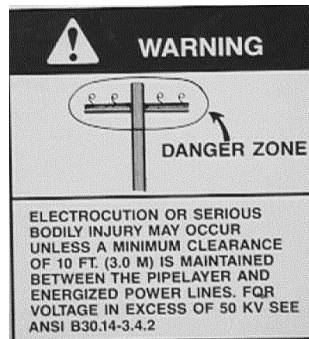

Figure 11: Electrocution Warning; located on left side access door of machine.

Electrocution or serious bodily injury may occur unless a minimum clearance is maintained between the machine or the load being handled, and energized power lines. See the following chart:

Minimum Distances

WHEN OPERATING NEAR LINES

Normal Voltage (Phase to Phase)	Minimum Required Clearance
Up to 50 kV	3.05 m (10 ft)
Over 50 to 200 kV	4.06 m (15 ft)
Over 200 to 350 kV	6.10 m (20 ft)
Over 350 to 500 kV	7.62 m (25 ft)
Over 500 to 750 kV	10.67 m (35 ft)
Over 750 to 1000 kV	13.72 m (45 ft)

WHILE IN TRANSIT WITH NO LOAD

Normal Voltage (Phase to Phase)	Minimum Required Clearance
Up to 0.75 kV	1.22 m (4 ft)
Over 0.75 to 50 kV	1.83 m (6 ft)
Over 50 to 345 kV	3.05 m (10 ft)
Over 345 to 750 kV	6.10 m (20 ft)
Over 750 to 1000 kV	7.62 m (25 ft)

Wire Rope

The wire rope must be evenly spooled onto the drum, or serious damage with resulting loss of strength may result. Keep hands, etc., away from moving wire rope, sheaves, and blocks. Wear protective gloves when handling wire rope. Replace wire rope that is corroded, kinked, worn, or has broken strands.

Precise rules for replacement cannot be given since many variable factors are involved. Continued use is a matter of good judgment on the part of an authorized person. Consult ANSI B30.14 for further details.

Collision Avoidance

The pipelayer attachment structures and the boom may extend considerable distance from the tractor. The operator must be aware of boom position and attachment structure clearance at all times. Ground personnel must be kept clear at all times and only approach the machine when signaled to do so by the operator.

Pinch Points

Wire ropes, sheaves, blocks, winch drums, the boom, and suspended loads all move during operation. Personnel must keep clear of the pinch points these elements create to avoid serious injury or death.

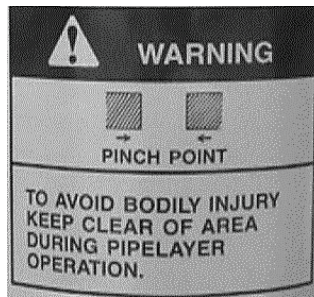

Figure 12: Pinch points.

Folding Boom Lock-Pins

Two lock-pins are required to fix the folding boom in the extended position. Install one lock pin at **each** of the two elbow joints, and latch the retainer rings.

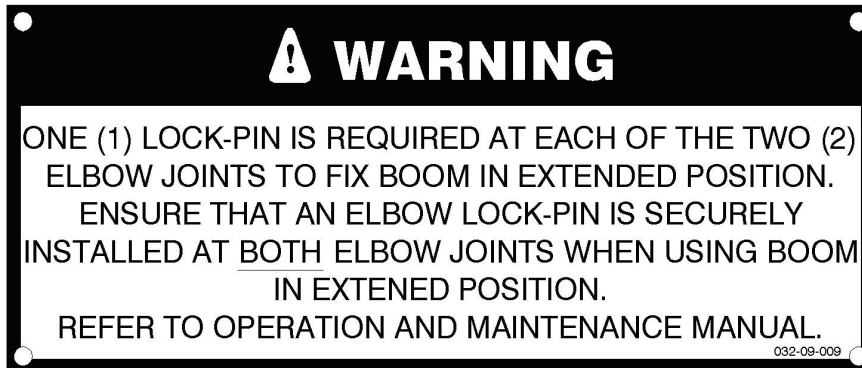

Figure 13: Folding boom lock-pin warning; Located at both elbow joints on folding boom.

Hand Signals

Standard hand signals, similar to those outlined in ANSI B30.14, should be followed.

Machine Parking



032-05-05-003

Figure 14: Parking machine.

- Park on level surface. If necessary to park on a grade, block the machine.
- Apply the service brake to stop the machine.
- Move the transmission control lever to "NEUTRAL" and the speed control to "LOW IDLE".
- Engage the parking/secondary brake.
- Lower any load to the ground.
- Refer to the tractor's operation manual for the specific procedures regarding engine shut down and/or other implement attachments.

High Hydraulic System Pressure

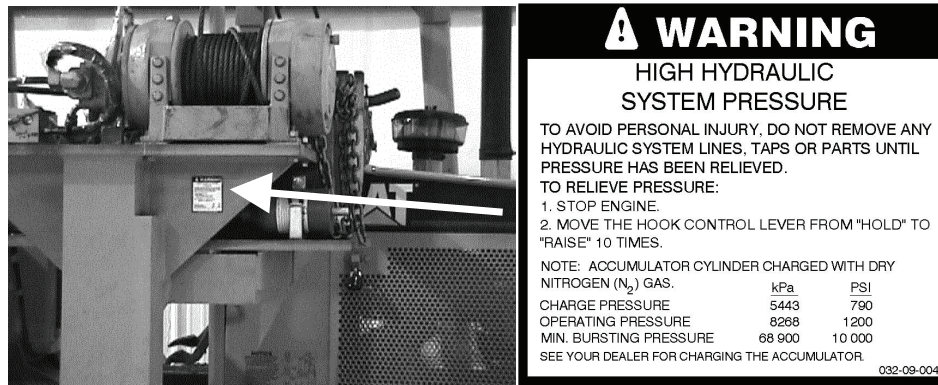

Figure 15: High pressure warning decal; located on front, outside edge of winch base.

NOTE: The hydraulic implement system and some machine controls are "LIVE" for as long as the accumulator holds a charge, even if the engine is not running. This pressure charge will take approximately four hours or more to bleed off.

To relieve the accumulator charge, with no load on the hook and the engine stopped, move the *hook control* lever from "HOLD" to "RAISE" 10 times.

Always move the *mode control* lever to the "LOCKED" position before shutting off the engine or immediately after the engine quits running to prevent unintentional load release or, after the engine is restarted, draw works operation.

NOTE: Refer to the **SAFETY SECTION** of the Operation and Maintenance Manual of the specific tractor for additional information.

Electrical Storm Injury Prevention

When lightning is striking or threatening to strike near the vicinity of the machine, the operator should **never** attempt the following procedures:

- Mount the machine.
- Dismount the machine.

If you are in the operator’s station during an electrical storm, stay in the operator’s station. If you are on the ground during an electrical storm, stay away from the vicinity of the machine.

Components and Specifications

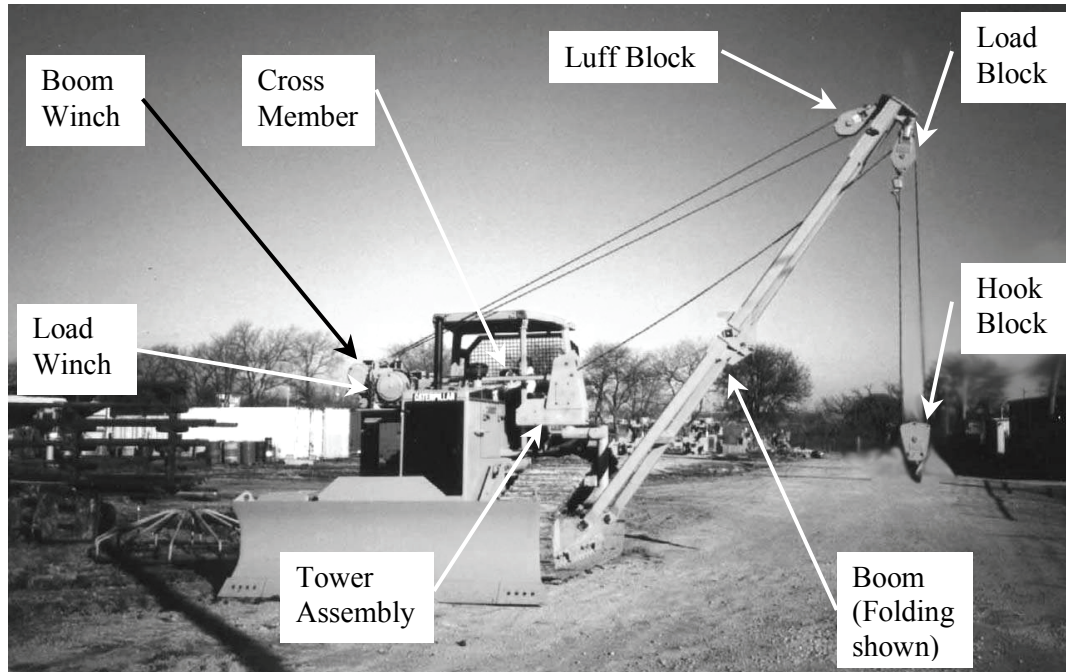

032-05-05-005A

Figure 16: Pipelayer main components.

VEI D4H LGP, D5M LGP, D5N LGP PIPELAYER			
	D4H LGP	D5M LGP	D5N LGP
Maximum tip load at 1.2m (4ft)	11 192 kg (24 675 lb.)	11 790 kg (26 000 lb.)	12 428 kg (27 400 lb.)
Folding boom length (extended)	5.5 m (18 ft)	5.5 m (18 ft)	5.5 m (18 ft)
Rigid boom length	6.1 m (20 ft)	6.1 m (20 ft)	6.1 m (20 ft)
Operating Weight (approximate)	15 160 kg (33 420 lb.)	16 330 kg (36 000 lb.)	16 565 kg (36 520 lb.)
Length (with blade straight)	4939 mm (194 in)	5105 mm (201 in)	5064 mm (199 in)
Width (boom removed) – calculated	3188 mm (125.5 in)	3188 mm (125.5 in)	3143 mm (123.75 in)
Width (folding boom folded)	3353 mm (132 in)	3353 mm (132 in)	3327 mm (131 in)
Height (less boom)	2986 mm (118 in)	3124 mm (123 in)	3038 mm (119.6 in)
Height (folding boom folded)	3429 mm (135 in)	3429 mm (135 in)	3429 mm (135 in)
Height (rigid boom vertical)	6756 mm (266 in)	6756 mm (266 in)	6746 mm (265.6 in)
Height (folding boom vertical)	6215 mm (244.7 in)	6215 mm (244.7 in)	6205 mm (244.3 in)

NOTE: Refer to the **GENERAL SECTION** of the *Operation And Maintenance Manual* of the specific tractor for additional information.

Lockout Cylinders

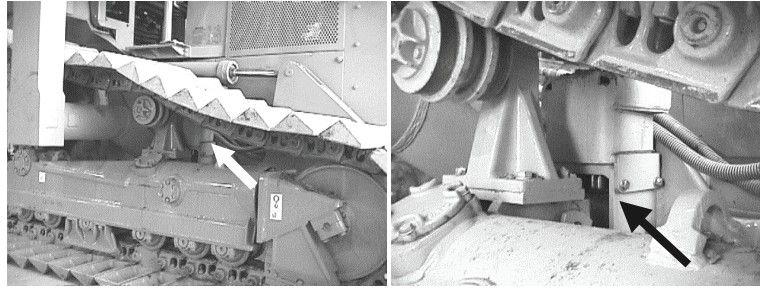

Figure 17: Equalizer bar lockout cylinder (one per side), shown deployed.

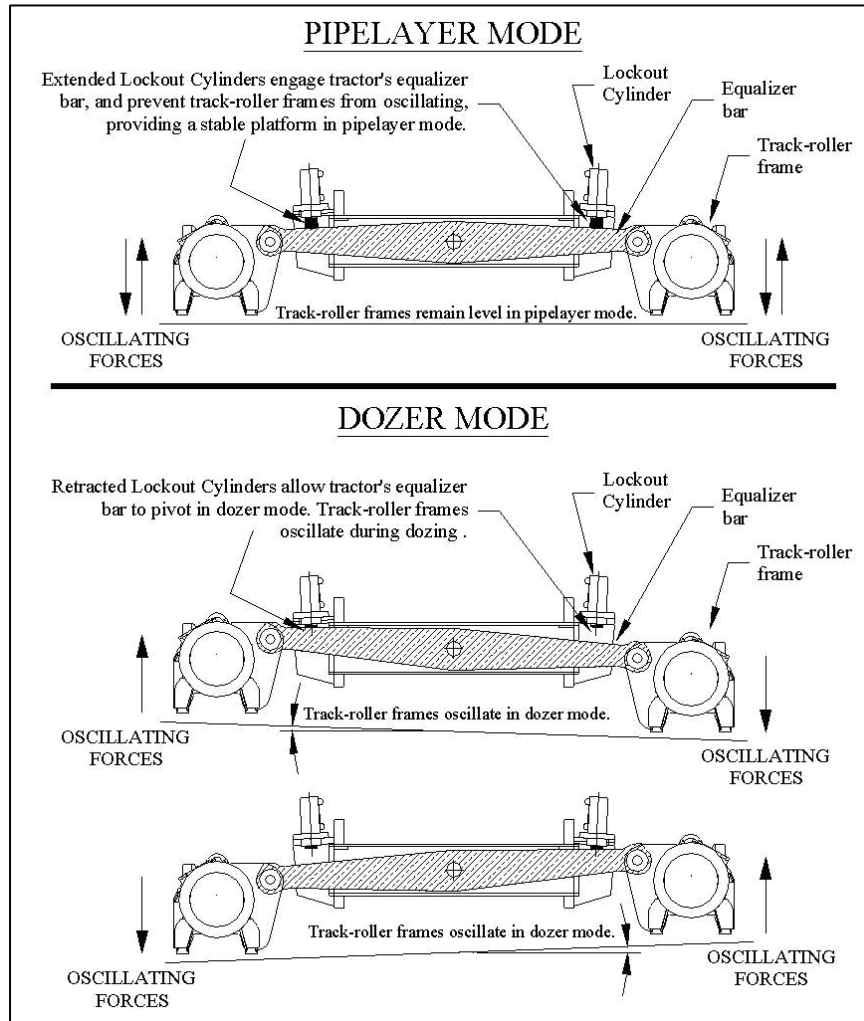

Figure 18: Lockout cylinder operational concept.

NOTE: NO DOZING SHOULD BE DONE IN PIPELAYER MODE, SWITCH TO DOZER MODE WHEN DOZING. Dozing in pipelayer mode—with the lockout cylinders extended—will damage the cylinders to the point where they will no longer provide adequate support for the sideboom during lifting. The suspended load may shift unexpectedly causing injury or death to personnel working around it; the entire sideboom may unexpectedly tip, resulting in personal injury or death. Before switching to dozer mode, lower any suspended load to the ground. **NO LOAD IS TO BE SUPPORTED OR CARRIED BY THE SIDE BOOM IN DOZER MODE.** Dozer-blade function speeds are significantly reduced in pipelayer mode.

032-08OP-007C

S/N D4H0038 – UP
S/N D5M0021 – UP
S/N D5N0021 – UP

The VEI pipelayer locks out the tractor's equalizer bar with hydraulically actuated cylinders. These cylinders automatically deploy in pipelaying mode, and automatically retract in dozing mode as controlled through the *mode control lever*. When deployed, they extend to contact the equalizer bar, preventing any upward movement, and providing a stable-lifting platform. The extended cylinders will retract when the maximum rated tip load is exceeded.

The *lockout cylinders* will not automatically level the tractor when initially deployed. By only allowing the equalizer bar to move down toward the level position, the tractor levels out through normal maneuvering. Pipelaying operations can occur as soon as the pipelaying mode is selected. While the tractor may initially feel unbalanced until it has been maneuvered about enough so that the equalizer bar levels out, the unit is stable as soon as the cylinders are deployed.

It is strongly recommended that the tractor be maneuvered about a short distance after the *mode control lever* is switched back to the dozing mode, before commencing dozing, to allow the *lockout cylinders* to hydraulically release and retract.

Draw Works Controls

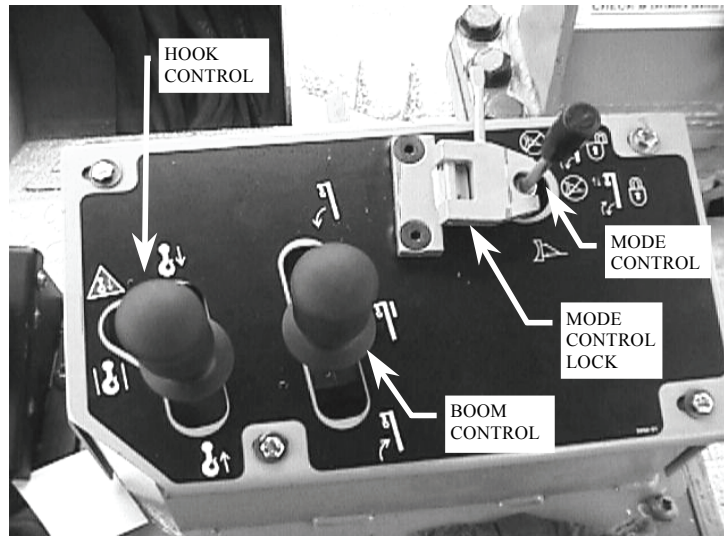

Figure 19: Draw works control box.

Mode control lever

The position of the lever selects the function (Pipelayer or Dozer) of the machine. The mode control is detented, and the lever will remain in position once released. It must be physically moved to the desired function.

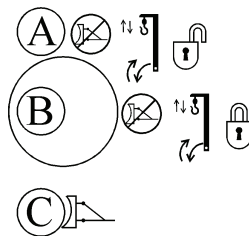

Figure 20: Mode control positions.

Limited Dozer Functions

In order to remind the operator not to carry out any bulldozing in Pipelayer Mode, the dozer-blade function speeds are significantly reduced in the two pipelayer modes. To regain full blade-function speeds for dozing, ensure that no load is supported from the sideboom and switch the Pipelayer Mode control to Dozer Mode.

- A) **PIPELAYER MODE—WINCH CONTROLS UNLOCKED:** Move the lever to this position to operate the unit in the pipelayer mode. The winch controls function; the equalizer *lockout cylinders* are deployed. The blade controls still function, however, **DO NOT CARRY OUT ANY BULLDOZING IN THIS MODE.**
- B) **PIPELAYER MODE—WINCH CONTROLS LOCKED:** To prevent accidental actuation of the winch controls while in pipelayer mode, move the lever to this position and flip the mode lock to engage the lever and lock it in position. While the winch controls do not function, the equalizer *lockout cylinders* are deployed so that a load can be supported or carried by the side boom. The blade controls still function, however, **DO NOT CARRY OUT ANY BULLDOZING IN THIS MODE.**

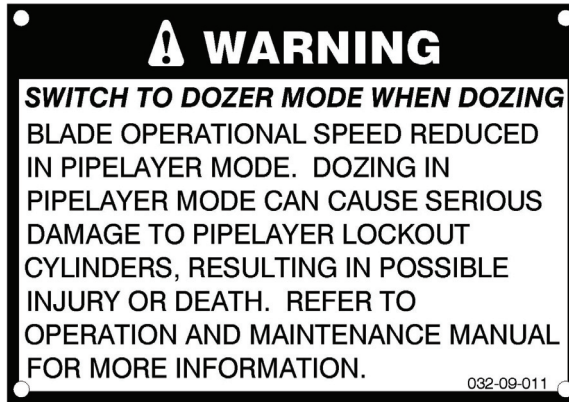



Figure 21: Mode control position warning; located by dozer-blade control.



Figure 22: Lower loads before switching to dozer mode warning; located on winch control box.

- C)  **DOZER MODE—WINCH CONTROLS LOCKED:** Before switching to dozer mode, lower any suspended load to the ground. **NO LOAD IS TO BE SUPPORTED OR CARRIED BY THE SIDE BOOM IN DOZER MODE.** Move the lever to this position to operate the unit as a bulldozer. The winch controls do not function; the equalizer *lockout cylinders* are retracted. The blade controls function.

Hook Control Lever

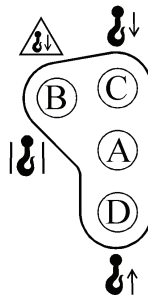



Figure 23: Hook control positions.

- A)  **HOLD:** The lever self centres to this position whenever it is released. In this position, the load winch brake will set, and the hook will stop and remain at the position it is in.

032-08OP-007C

S/N D4H0038 – UP
S/N D5M0021 – UP
S/N D5N0021 – UP



Figure 24: Quick drop still live warning; located on winch control box.

- B)  **EMERGENCY LOWER (Quick Drop):** Move the *hook control* lever to this position to lower the load fast in an emergency. The load winch's quick drop brake will release, and the hook will move down under the weight of the load. The lever will return to the "**HOLD**" position when released, the load winch brake will set and the hook will stop and remain at the position it is in.

NOTE: Quick drop is only available in pipelayer mode—winches unlocked.

- C)  **LOWER:** Move the lever to this position to lower the hook with controlled winch power. The further the lever is pushed away from "**HOLD**", the faster the hook will lower. The closer the lever is toward "**HOLD**", the slower the hook will lower. When the lever is released, it will return to the "**HOLD**" position, the winch brake will set, and the hook will stop and remain at the position it is in. Hook winch line speed varies with engine throttle setting. Hook control is smoothest at engine speeds faster than idle.

- D)  **RAISE:** Move the lever to this position to raise the hook. The further the lever is pulled away from "**HOLD**", the faster the hook will raise. The closer the lever is toward "**HOLD**", the slower the hook will raise. When the lever is released, it will return to the "**HOLD**" position, and the hook will stop and remain at the position it is in. Hook winch line speed varies with engine throttle setting. Hook control is smoothest at engine speeds faster than idle.

Boom Control Lever

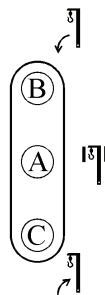





Figure 25: Boom control positions.

- A)  **HOLD:** The lever self centres to this position whenever it is released. In this position, the boom winch brake will set, and the boom will stop and remain at the position it is in.

- B)  **LOWER:** Move the lever to this position to lower the boom. The further the lever is pushed away from "HOLD", the faster the boom will lower. The closer the lever is toward "HOLD", the slower the boom will lower. When the lever is released, it will return to the "HOLD" position, and the boom will stop and remain at the position it is in. Boom winch line speed varies with engine throttle setting. Boom control is smoothest at engine speeds faster than idle.

- C)  **RAISE:** Move the lever to this position to raise the boom. The further the lever is pulled away from "HOLD", the faster the boom will raise. The closer the lever is toward "HOLD", the slower the boom will raise. When the lever is released, it will return to the "HOLD" position, and the boom will stop and remain at the position it is in. Boom winch line speed varies with engine throttle setting. Boom control is smoothest at engine speeds faster than idle.

Boom Stop Valve

WARNING

The Boom Stop system stops the boom winch from hauling-in when the boom is vertical, preventing overloading of key machine components. Defeating the boom stop valve could result in serious equipment damage, personnel injury, or even death. Its operation must be check and verified daily.

 **WARNING**

BOOM STOP VALVE
LOCATED
UNDERNEATH.
CHECK OPERATION
DAILY.
ADJUST TRAVEL TO
STOP BOOM-WINCH
WITH BOOM VERTICAL.
REFER TO OPERATION
AND MAINTANCE
MANUAL.

030-09-007

The Boom Stop valve is a safety device that is intended to automatically stop the boom winch from hauling-in when the boom is vertical, preventing overloading of key machine components. Refer to the Operation and Maintenance manual, Boom Stop Valve Adjustment, for correct operation and adjustment. Check its function daily.

Folding Boom

! WARNING

Extending or stowing the folding boom must be done with the machine on level ground.

Extending

1. Unhook stowing chain from top of folded boom and stow in the clip on the winch frame.
2. Provide support for the lower boom section so that it will be slightly below horizontal when unfolded, by either of the following means:
 - a) Block to ground.
 - b) Chain to left-hand frame.

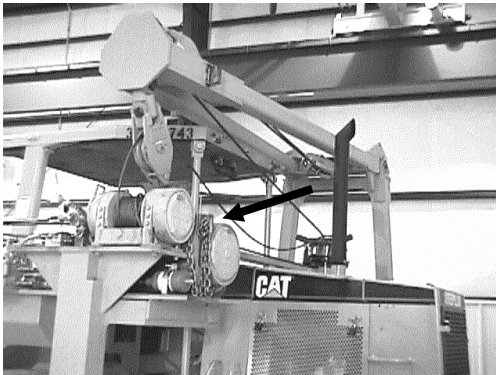

Figure 26: Stowing chain unclipped from boom.

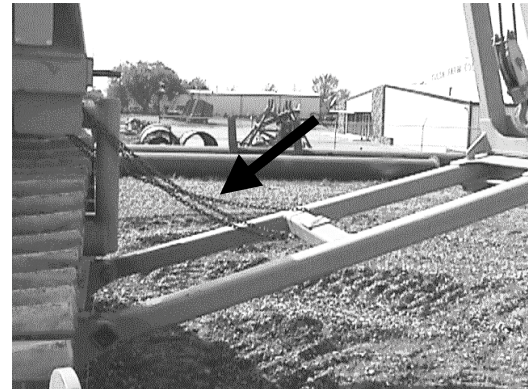
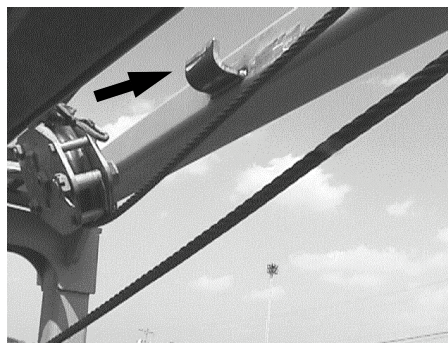

Figure 27: lower folding boom section chained for support.

3. For Type I sidebooms (S/N D5M0021 - S/N0042 and D4H0038 – D4H0042, remove the hook and boom lines from the cable-stowing bracket on the upper section of the folded boom. Type II sidebooms are not fitted with cable-stowing brackets.



**Type I S/N D4H0038-D4H0042
S/N D5M0021-D5M0042**

Figure 28: Lines removed from cable-stowing bracket, Type I booms.

4. Begin to unfold the boom using the hook and boom winches together. Haul in (raise) on the hook winch and pay out (lower) on the boom winch. Keep only enough slack in the boom line so that it closely follows the unfolding boom.
5. After the upper folded section goes over centre (hook line vertical), the boom line will support the folded boom. To unfold the boom further, pay out (lower) on the boom winch and pay out (lower) on the hook winch. Keep only enough slack in the hook line so that it closely follows the unfolding boom.

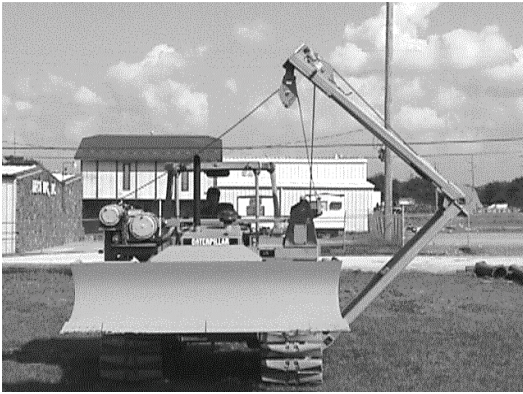

Type I S/N D4H0038-D4H0042
S/N D5M0021-D5M0042

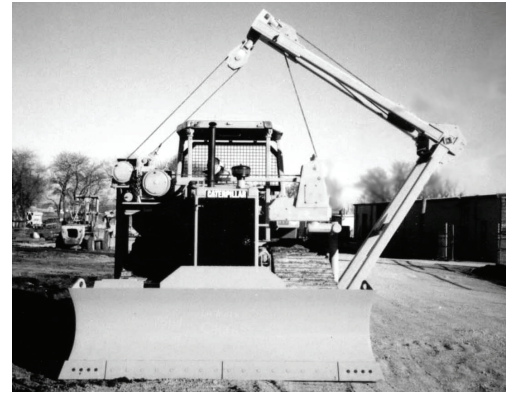

Type II S/N D4H0043-UP 032-05-25-002
S/N D5M0043-UP, S/N D5N0021-UP

Figure 29: Extending folding boom over centre.

6. Unfold the boom until the lower section rests on the support that was set-up in step 1. Continue to unfold until the top section is straight with the lower section.
7. Two lock-pins are required to fix the folding boom in the extended position. Remove the boom-elbow lock-pins from their stowing holes in the lower boom section at the uppermost cross-member. Install one lock-pin at **each** of the two elbow joints, and latch the retainer rings.



032-25-09-001

Figure 30: Boom-elbow lock pin installed at elbow joint.

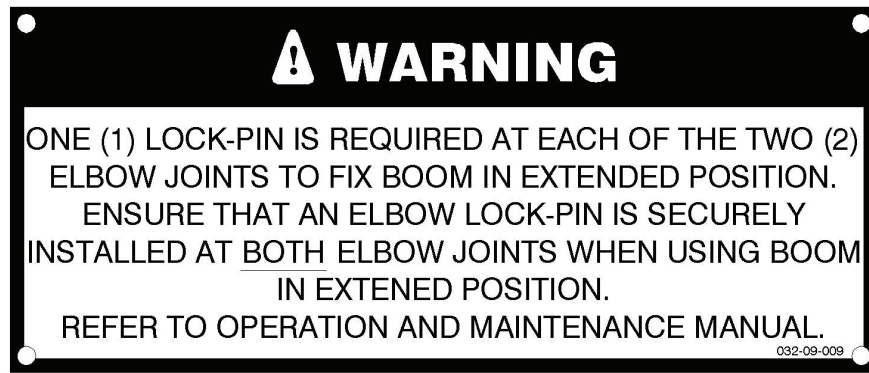

Figure 31: Folding boom lock-pin warning; located at both elbow joints on folding boom.

8. Raise the boom and remove the support. The boom is now ready for use.

Stowing

1. Lower the boom to approximately the horizontal position.

2. Provide support for the lower boom section by either of the following means:
 - a) Block to ground.
 - b) Chain to winch frame.
3. Slacken off the boom and hook lines.
4. Remove the boom-elbow lock pins and store them in their stowing holes in the lower boom section at the uppermost cross-member.
5. Begin to fold the boom using the boom and hook winches together. Haul in (raise) on the boom winch and follow with the hook winch. Keep only enough slack in the hook line so that it closely follows the folding boom.
6. When the upper section is close to 90° with the lower section, hook the hook block into the stowing bracket at the bottom of the upper boom section.

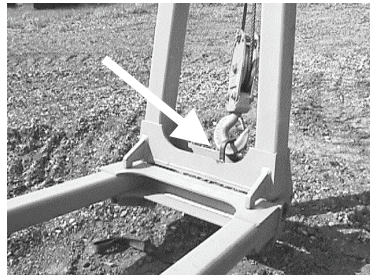

Figure 32: Hook block in folding boom stowing bracket.

7. Once the upper boom section is perpendicular (at a 90° angle) to the lower section, the entire boom rotates about the boom pivot pin on the track-roller frame bracket. Continue to haul in (raise) on the boom winch and pay out (lower) on the hook winch. Keep only enough slack in the hook line so that it closely follows the unfolding boom.
8. Keep a watchful eye on the hook line tension. As the boom continues to fold and goes over centre, hauling in (raising) on the hook line will tighten it, increasing the stress on the boom. As soon as this point is reached, the hook line must be played out (lowered) to continue to closely follow the boom.



Type I S/N D4H0038-D4H0042
S/N D5M0021-D5M0042



Type II S/N D4H0043-UP
S/N D5M0043-UP, S/N D5N0021-UP

Figure 33: Stowing folding boom over centre.

! WARNING

Failure to pay out (lower) the hook line after the boom goes over centre could result in serious damage and possible injury or death.

032-08OP-007C

S/N D4H0038 – UP
S/N D5M0021 – UP
S/N D5N0021 – UP

9. Slowly pay out (lower) the hook winch and haul in (raise) on the boom winch to continue to fully fold the boom. Keep only enough slack in the hook line so that it closely follows the unfolding boom.

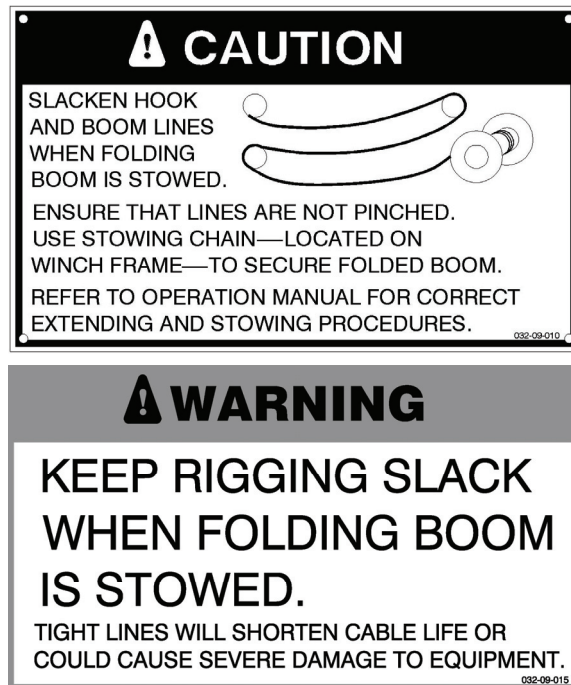

Figure 34: Slacken lines on stowed folding boom; Located on winch guard to right of operator.

10. With the boom completely folded, pay out (lower) both the boom and hook lines to leave enough slack—approximately two to three feet—so that the boom is not over stressed during dozing or transport. Ensure that blocks, etc., do not pinch the cables.
11. Secure the top of the folded boom with the stowing chain attached to the winch frame. Leave enough slack in the chain so that the boom will be able to move as the track roller frames oscillate, but keep the length short enough so that the top section of the boom cannot bounce excessively.

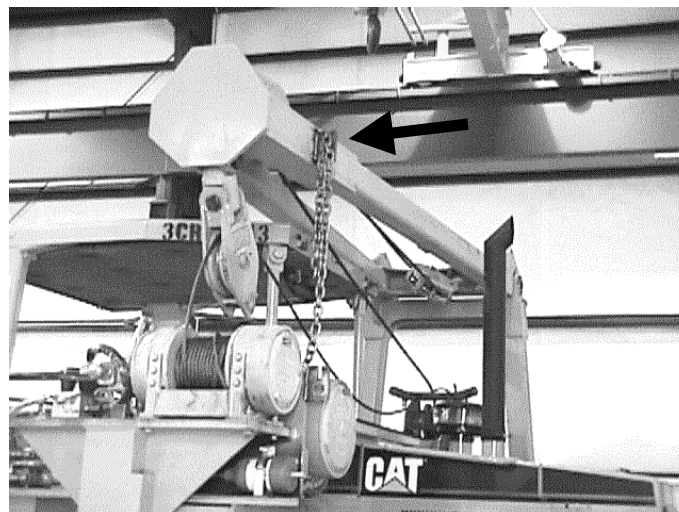

Figure 35: Folding boom secured to stowing chain.

12. Move the *mode control* lever to **dozer mode** to lockout the winches to prevent accidental operation of the draw works while the boom is folded, and to allow the track roller frames to oscillate for dozing operations.

Boom Removal and Installation (Folding and Rigid booms)

- Folding boom should be locked in the extended position.
- Lower the boom onto blocks.
- Remove the cotter pin and block pin from the load-block. Lower the load-block to the ground. Replace the pins in the boom.
- Draw in the load cable in order to pull the sheave blocks to the machine. Lift the sheave blocks and fasten them to the machine for shipping. The weight of the load-block is approximately 27 kg (60 lb.). The weight of the hook-block is approximately 38 kg (85 lb.).
- Raise the boom to the horizontal position. Block up the boom. Remove the cotter pin and the pin from the luff-block. Lower the luff-block to the ground. Replace the pins in the boom.
- Draw in the cable for the boom in order to pull the luff-block to the machine. Lift the luff-block and fasten it to the machine for shipping. The weight of the luff-block is approximately 27 kg (60 lb.).
- Connect a lifting cable to the boom. Remove the boom-pin pivot shafts and shims from the track roller frame and lift the boom from the machine. The weight of the rigid boom is approximately 544 kg (1200 lb.). The weight of the folding boom is approximately 680 kg (1500 lb.).
- Replace the boom-pin pivot shafts and shims in the track roller frame.
- Installation is the reverse order. Reinstalling boom pivot shims in such away as to centre the boom on the track roller frame.

Maintenance and Lubrication

General

- Follow tractor manufacture's maintenance and lubrication instructions for tractor service as required.
- Follow tractor and/or winch manufacture's lubrication instructions for the pipelayer hydraulic system.
- To prevent corrosion damage to the winch interiors, if not used regularly, run winches up and down at least once every two weeks.

Lubricant Viscosities

System	Oil Viscosity	Ambient (outside) Temperatures			
		°C		°F	
		Min	Max	Min	Max
Boom winch gear train.	SAE 80W90	-30	+50	-22	+122
Hook winch gear train	SAE 80W90	-30	+50	-22	+122
Hydraulic system	See tractor operation and maintenance manual				

Refill Capacities

System	Refill Capacities (approximate)		
	Liters	US Gal.	Imperial Gal.
Hydraulic tank	32	8.5	7.0
Hydraulic system (includes tank)	78.4	20.7	17.0
Boom winch gear trains	1.5	0.4	0.3
Hook winch gear trains	3.8	1.0	0.8

Pipelayer Service Intervals

Wire rope cable

Visually inspect all running ropes that are in continuous service at least once per working day. Inspect all ropes at least once a month. Keep a dated report of the condition of the rope on file in a location that is available to designated personnel. A designated person shall perform all inspections. Perform a close inspection of sections of the rope that are normally hidden during the visual inspection and maintenance inspection; this includes parts of the rope that pass over the sheaves, as these points are the sections of rope that are most likely to fail. Note any deterioration that results in a notable loss of the original strength, as outlined below.

Inspect the cable on a daily basis for the following conditions:

032-08OP-007C

S/N D4H0038 – UP

S/N D5M0021 – UP

S/N D5N0021 – UP

- Inspect the cable for a reduction in the diameter of the cable below the nominal diameter. A reduction in the diameter of the cable can occur because of: the loss of core support, internal corrosion, external corrosion, wear of the outside wires.
- Inspect the cable for broken outside wires. Check for the degree of distribution of the broken outside wires. Check for the concentration of outside broken wires.
- Inspect the cable for worn outside wires.
- Inspect the cable for corroded end connections, for cracked end connections, for worn end connections, or for improperly applied end connections.
- Inspect the cable for kinks, for sections of cable that are crushed, for cuts in the cable, or for any strands that have come loose.

Excessive wear or broken wires may occur in sections that are in contact with saddles, equalizer sheaves, or with other sheaves, and where rope travel is limited. Take care to inspect the ropes at these locations.

When a machine is shutdown for a month or more, inspect all rope thoroughly. When a sideboom machine has been in storage for a month or more, inspect all ropes thoroughly. A designated, authorized person should perform the inspection. The authorized person's approval is required for further use of the rope. A dated report on the condition of the rope should be kept on file.

Take care in the inspection of rope that is resistant to rotation.

Any new poured socket or swaged socket assembly that is used as a standing rope or guy, shall be proof tested to the lift capacity of the sideboom machine or to the manufacturer's recommendation. Never give the cable a rating that is greater than 50 percent of the component wire rope's nominal strength or of the structural strand's nominal strength.

Note: For additional information on the proper maintenance and on inspection of the cable, refer to "American National Standards Institute ANSI/ASME B30.14"

Service Intervals

Note: Before each consecutive interval is performed, all maintenance from the previous interval must be performed. Perform the following servicing at EVERY interval they occur; for example, the 10 hour and 50 hour service are also performed at the 200 hour interval, etc.

10 Hours Service Interval or Daily

- Check hydraulic oil level as per tractor's operation/maintenance manual.
- Check hoses and fittings for leaks.
- Check controls for proper operation of boom and hook.
- Check for correct function of boom stop valve.
- Check lockout cylinders for leaks, loose fittings, and loose or damaged bolts, etc. Ensure that the guards and cylinders are securely in place. Ensure that the cylinders extend in pipelayer mode and retract in dozer mode (it may be necessary to move the dozer to allow the cylinders to unlock and retract).
- Check pipelayer structures and components for loose bolts.
- Inspect the hook for any distortion, bends, twists, etc. Inspect the hook for any wear, cracks, nicks, or gouges. Refer to American National Standard Institute ANSI/ASME B30.1
- Inspect blocks, and yokes for wear or damage.
- Inspect wire rope for proper spooling, wear, broken or damaged wires, corrosion, and damage at end connections; replace as required per specifications in rigging section.
- Inspect folding boom-elbow lock pins for wear or damage, replace as required.
- Inspect the folding boom-elbow lock pin bores at the lower and upper boom sections' elbow-joints for excessive elongation, repair as required.
- Grease fairlead sheave, tail block, load block, luff-lock, and hook block bearings.
- Grease boom-pin pivot shafts.
- Check to ensure that area between tractor tracks and pipelayer-tractor attachment structures are free from dirt, debris, ice, snow, etc.

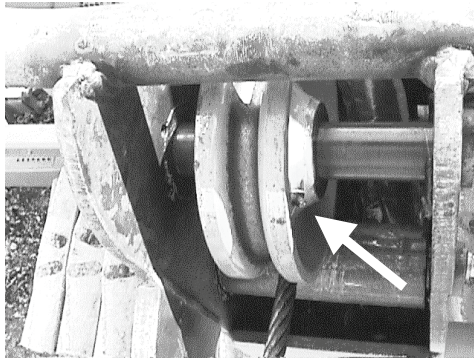

Figure 36: Fairlead sheave grease nipple.

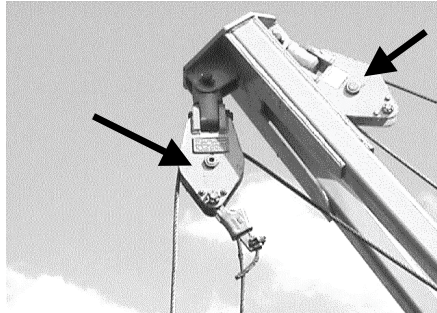

Figure 37: Load and luff block grease nipples.

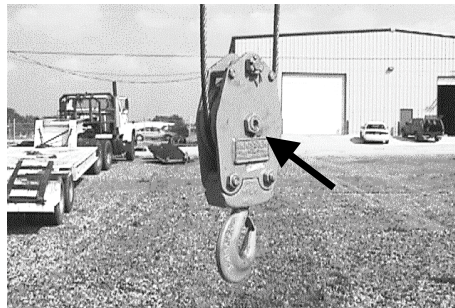

Figure 38: Hook block grease nipple.

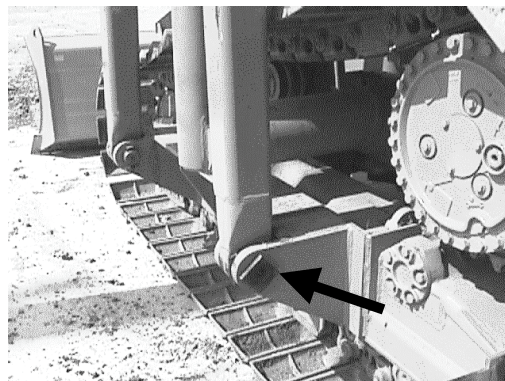

Figure 39: Boom-pin pivot shaft grease nipples (one on forward and rear).

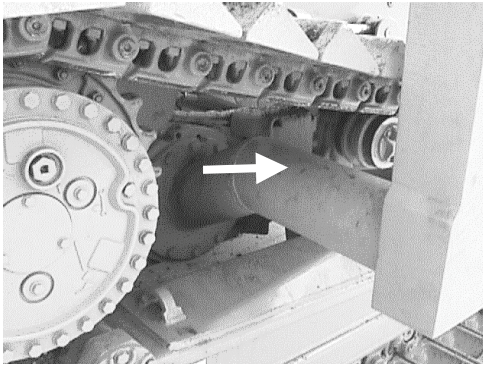

Figure 40: Attachment structures free from debris.

50 Hours Service Interval or Weekly

- Lightly lubricate wire rope with recommended engine or hydraulic oil.
- Inspect the wear of the nylon bushing at the outer end of the boom kick-out rod. If boom kick-out plate on boom will soon wear through the bushing to make direct contact with the tower when the boom is vertical, then the bushing should be replaced immediately.
- Check track tension to ensure that the tracks are not too loose. Loose tracks can damage the pipelayer attachment structures.

200 Hours Service Interval or Monthly

- Inspect the wear of the inner boom stop bushing on the kick-out rod, inside the boom stop valve compartment in the tower. Move the boom in to verify the alignment of the kick-out rod with the boom stop valve through the complete contact-travel range of the two. If the centre of the kick-out rod is misaligned with the centre of the boom stop valve plunger by more than 4.8 mm (3/16-in), throughout the entire 10 mm (3/8") contact travel range of the rod with the valve, replace BOTH the inner boom stop bushing AND the outer kick-out rod nylon.



038-07-66-001A

Figure 41: Check inner and outer boom stop bushings.

500 Hours Service Interval or 3 Months

- Change hydraulic system filter element.
- Change winches' gear train oil (SAE 80W90).

2000 Hours Service Interval or 1 Year

- Change hydraulic system oil.

Wire Rope

- Lightly lubricate wire rope with engine oil.

Accumulator

- Accumulator to be charged with dry nitrogen (N₂) gas, by qualified personnel, refer to High Hydraulic System Pressure safety section for charge pressure.

Boom Stop Valve Adjustment

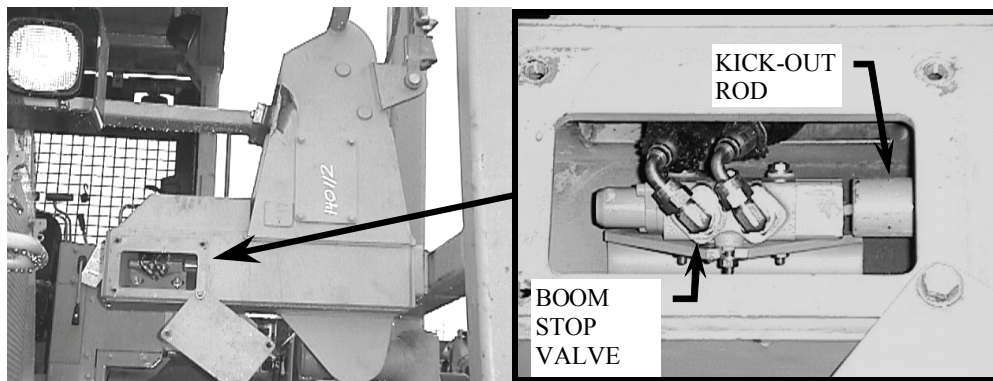

Figure 42: Boom stop valve located in tower.

- Raise the boom vertical so that it is **JUST** in contact with the tower; boom kick-out rod is fully retracted into the tower, with the kick-out disc bushing against the tower. Do not over tighten the lines to the point that the boom or left structures are overly stressed.
- Remove the boom stop valve access panel from the tower.
- Loosen the boom stop valve nuts.
- Move the valve so that it just contacts the boom kick-out rod.
- Move the valve an additional 10 mm (3/8") towards the boom.
- Tighten the valve in position with the valve nuts.
- Replace the cutout valve access panel from the tower.

Air Conditioner Filter Access (Cab models only)

Lower the boom all the way to the ground. The cross member unbolts from the tower and swings up to allow access to the air conditioner filter access panel. The tower houses extra length for the hydraulic control hoses that run through the cross member. Ensure that the extra hose length is neatly stowed in the tower, out of the way of the load line when the cross member is reinstalled.

NOTE: The cross member must be completely reinstalled, and the mounting bolts tightened, prior to operating the draw works.

Winch Train Oil Change

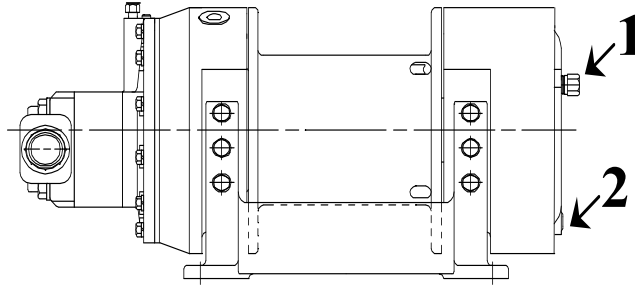

Figure 43: Winch train oil ports.

- Place a suitably large container (at least 4 liters or 1 US gallon) under the drain plug (2) to collect drained oil.
- Remove fill plug (1) and drain plug (2) and allow oil to drain into the container.
- After all of the oil has drained from the winch drive train, install the drain plug (2).
- Fill the winch with new oil until level with the bottom of the fill plug port.
- Install the fill plug (1).
- Dispose of used oil in an environmentally sound manner (e.g. take to a recycling centre).
- Check winch train oil level after 24 hours. Add oil to top off level if necessary.

Rigging



Do not use wire rope that is kinked, frayed, or has worn spots. Wear gloves when handling wire rope.

Wire Rope Specifications

Unroll the wire rope from the spool, never lift it off in loops.

Note: Weld, braze, or seize ends of wire rope before installing to prevent fraying.

18 ft Folding Boom

Line	Length	Specification	Size dia.
Load line	22.6 m (74 ft)	637IWRC USA made [41 200 lb. (18 700 kg) minimum breaking strength]	5/8-in (16 mm)
Boom line	19.4 m (63.6 ft)	637IWRC USA made [26 600 lb. (12 070 kg) minimum breaking strength]	1/2-in (13 mm)

20 ft Rigid Boom

Line	Length	Specification	Size dia.
Load line	24.3 m (80 ft)	637IWRC USA made [41 200 lb. (18 700 kg) minimum breaking strength]	5/8-in (16 mm)
Boom line	20.6 m (67.7 ft)	637IWRC USA made [26 600 lb. (12 070 kg) minimum breaking strength]	1/2-in (13 mm)

Load Winch Line Installation

- Lower the boom to the ground and support the boom.
- Unwind the load line from the winch drum.
- Disconnect the wire rope anchor from the load drum.
- Unroll the new load line wire rope from the spool, never lift it off in loops.
- Weld the wire rope ends to prevent fraying.
- Install the wire rope ferrule to the load winch drum; follow the PULLMASTER winch rigging procedures outlined in appendix.
- Spool half of the wire rope evenly across the load winch drum.

- Reeve the wire rope cable from the load winch drum under the tower fairlead sheave on the left structure, over the upper load-block on the boom, under the hook-block sheave, and into the cable socket on the upper load-block. Anchor the wire rope with the wedge. Install cable clamp on end of wire rope as per Crosby instructions outlined in the appendix.

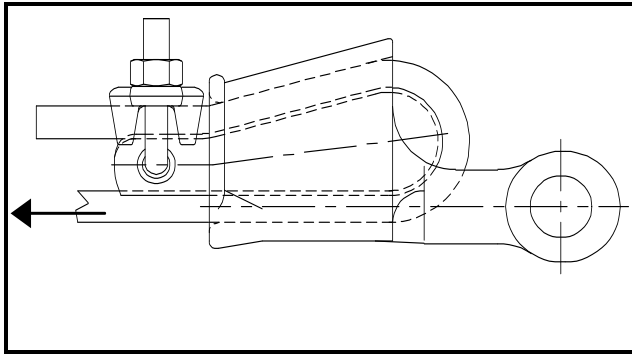
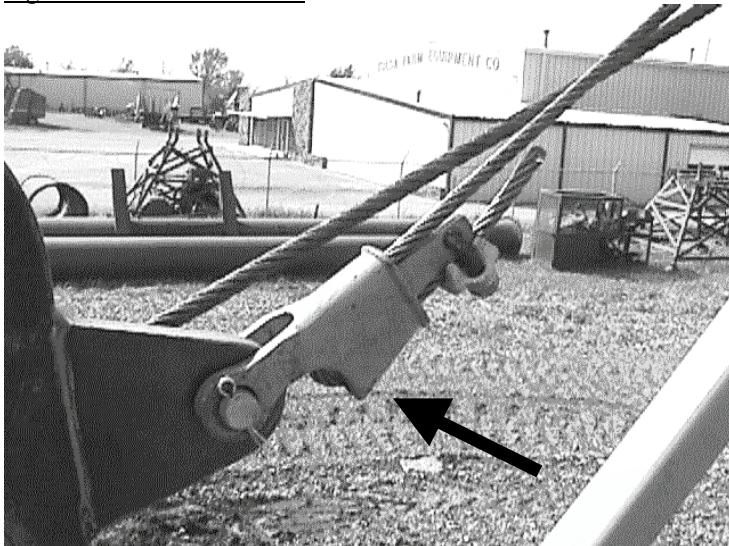
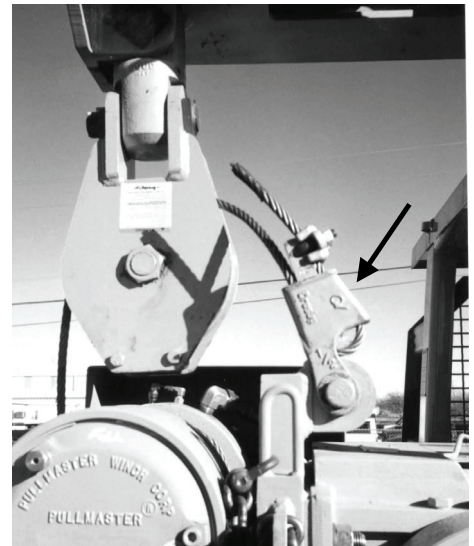

Figure 44: Line terminators.



Type I S/N D4H0038-D4H0042
S/N D5M0021-D5M0042



Type II S/N D4H0043-UP 032-05-30-002
S/N D5M0043-UP, S/N D5N0021-UP

Figure 45: Boom line terminator.

Note: Weld, braze, or seize end of cable before inserting cable into socket.

Boom Winch Line Installation

- Lower the boom to the ground and support the boom.
- Unwind the boom line from the winch drum.
- Disconnect the wire rope anchor from the boom drum.
- Unroll the new load line wire rope from the spool, never lift it off in loops.
- Weld the wire rope ends to prevent fraying.
- Install the wire rope ferrule to the boom winch drum; follow the PULLMASTER winch rigging procedures outlined in the appendix.
- Spool half of the wire rope evenly across the boom winch drum.
- Reeve the wire rope from the boom winch drum over the upper boom block sheave on the boom, and secure it to the line terminator, as per Crosby instructions outlined in the appendix. On Type I machines, the terminator is located on the top-front lug on the tower, on Type II it is located above the hook winch on the winch frame.

Appendix: Rigging Anchor procedures



THE LOGICAL CHOICE

**PULLMASTER WINCH CORPORATION
8247-130TH STREET, SURREY, B.C., CANADA, V3W 7X4
TELEPHONE: (604) 594-4444
FAX: (604) 591-7332**

OPERATING INSTRUCTIONS



**FAILURE TO FOLLOW OPERATING INSTRUCTIONS WILL
RESULT IN PROPERTY DAMAGE, SEVERE INJURY OR DEATH.**

After the PULLMASTER planetary winch has been installed in accordance with the INSTALLATION INSTRUCTIONS, the wire rope can be fastened to the cable drum.

IMPORTANT: The ropes, chains, slings, etc. are not part of the winch and are not covered by this manual. Refer to manufacturer's handling, inspection and maintenance recommendations to avoid potential accidents. For selection of ropes, etc. please check following product standards: DIN 15020, prEN818-1/9, prEN 1492-1/2, prEN 1677-1/3 and other relevant product standards.

- 1) The cable drum of the PULLMASTER planetary winch has two cable anchor slots, one for clockwise and one for counterclockwise hoisting. Standard rotation for hoisting is clockwise when looking at the hydraulic motor of the unit. It is critical to select the cable anchor slot which will permit winding of the wire rope on the drum in the correct direction of rotation. If the wire rope is wound on the cable drum in the wrong direction of rotation, the winch will have no braking capacity. Each winch is shipped from the factory with a label on the drum indicating the correct cable anchor slot.

WIRE ROPE INSTALLATION

Clockwise hoisting winch shown.
(Use cable anchor slot on opposite side of drum for counterclockwise hoisting winch.)

Feed the wire rope through the cable anchor slot. Loop rope back into slot as shown. Insert cable anchor into slot, small end first and long side nearest the drum flange. Pull rope tight to wedge rope in slot.

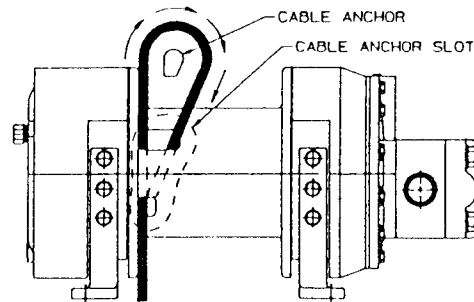

SH1013 - M12

- 2) On wire rope installation, care must be taken that the wire rope is wrapped completely around the cable anchor and properly pulled into the cable anchor slot in the cable drum. The cable drum requires 3-4 wraps of wire rope for safety.
- 3) The winch operation is controlled by a single control valve lever which has a **forward**, a **reverse** and a **neutral** position. Speed control in either direction is obtained by modulation of the control valve lever. Maximum line speed in either direction is obtained when the control valve lever is moved as far as it can go. The disc brake of the winch will come on automatically when the winch control lever is returned to **neutral**.
- 4) Always warm up equipment prior to operating winch, particularly in low ambient temperature. Circulate hydraulic oil through the winch control valve for several minutes to warm the hydraulic system. To prime the winch with warm oil, operate the winch at slow speed, forward and reverse, several times.
- 5) Prevent corrosion damage to winch interior. If not used regularly, run winch up and down at least once every two weeks.
- 6) To ensure proper winch installation and function, raise and lower a full test load to a safe height before using winch for regular operation at the start of each shift.

If, after a new installation, the winch does not function properly, refer to the TROUBLESHOOTING section of this manual.

TROUBLE SHOOTING

GENERAL:

In most cases, when the hydraulic winch does not perform satisfactorily, the cause for malfunction is found somewhere in the hydraulic circuit. Before the winch is removed from its mounting and disassembled, all of the hydraulic circuit components should be checked for proper function.

IMPORTANT:

The hydraulic oil volume relates to the line speed or rpm of the winch.

Therefore, if the winch does not produce the specified maximum rated line speed or drum rpm, a loss of hydraulic flow somewhere in the hydraulic circuit can be analysed. If this condition exists, install a flow meter into the hydraulic circuit to check the volume of oil supplied to the pressure port of the hydraulic winch motor when the winch control is completely opened. The flow meter should indicate the maximum operating volume. If this test indicates a loss of hydraulic flow, check the hydraulic pump, the relief valve and the control valve. If the pump is driven by V-belts, check for belt slippage.

The hydraulic pressure relates to the pulling capacity of the winch.

If the winch will not produce the specified maximum line pull, install a pressure gauge in the pressure line leading to the hoisting port on the hydraulic winch motor. Stall the winch to prevent rotation of the drum and then open the control valve. Check the hydraulic pressure reading of the installed pressure gauge. If the pressure reads below the specified maximum operating pressure, look for trouble in the hydraulic pump, the relief valve and the control valve. If the hydraulic pump is driven by V-belts, check for belt slippage. When checking oil pressure and volume in the hydraulic circuit, make sure that the hydraulic reservoir is filled to the top level and the hydraulic pump is running at maximum operating rpm.

Only after the hydraulic system has been checked and found to be in order, use the following indications for probable causes of failure in the winch:

<p>Winch will not produce line pull at maximum pressure as listed in SPECIFICATIONS.</p>	<ul style="list-style-type: none"> a) Winch is mounted to an uneven surface. (See INSTALLATION INSTRUCTIONS.) b) Cable sheaves or block purchase operated with the winch are not turning freely. c) Damage or wear in the hydraulic motor. d) The relief valve pressure may be set too low. (See SPECIFICATIONS for maximum operating pressure.) e) Excessive back pressure in the hydraulic circuit might cause the automatic brake to release momentarily.
<p>Winch will not produce line speed at maximum volume as listed in SPECIFICATIONS.</p>	<ul style="list-style-type: none"> a) Winch is mounted to an uneven surface. (See INSTALLATION INSTRUCTIONS.) b) Cable sheaves or block purchase operated with the winch are not turning freely. c) Damage or wear in the hydraulic motor. d) Excessive back pressure in the hydraulic circuit.
<p>Winch will not reverse.</p>	<ul style="list-style-type: none"> a) Leakage out of the brake piston prevents the disc brake from being released against the brake springs. This is caused by damaged O-ring seals on the brake piston. b) The O-ring seals on the brake release channel between the motor adaptor and the brake housing is damaged. If this failure occurs there will be substantial leakage from between the motor adaptor and brake housing. c) Insufficient hydraulic pressure. (See SPECIFICATIONS for minimum operating pressure.) d) Winch is mounted to an uneven surface. (See INSTALLATION INSTRUCTIONS.) e) Hydraulic pressure is not reaching the brake piston as a result of plugged brake release orifice in the brake housing.

TROUBLE SHOOTING CONTINUED

FAILURE	PROBABLE CAUSE
Brake will not hold.	<ul style="list-style-type: none"> a) Brake plates or divider plates have been damaged by contamination in the hydraulic fluid or lack of circulation flow in the brake housing. b) Brake piston is seized in the brake housing because of contamination in the hydraulic fluid. c) Excessive back pressure in the return line of the hydraulic circuit causes the brake to release. d) Control valve has incorrect spool which traps hydraulic pressure in the brake piston when the control valve handle is returned to neutral position. For proper function of the automatic brake, both pressure ports of the winch must be open to the reservoir in neutral position of the control valve. e) Wire rope is fastened to the incorrect cable anchor slot. f) Sprag clutch is damaged or surface where sprag clutch engages on motor drive shaft or brake hub are worn or indented. g) Winch supplied with external brake release option is not plumbed per TYPICAL HYDRAULIC CIRCUIT. Failure to vent external brake release port to reservoir may trap pressure and cause winch brake to slip.
Brake vibrates when lowering a load.	<ul style="list-style-type: none"> a) Pump is too slow. Pump rpm must be maintained at normal operating speed when a load is lowered. b) Brake is running too hot. This is caused by insufficient circulation flow. To check the circulation, observe the flow of oil from the circulation return line of the winch (approx. 3 (US) gpm - 11 l/min) when the winch is reversed. c) Control valve for the winch operation has poor metering characteristics. d) Damaged brake plates or divider plates. e) The over-running clutch, which connects the motor shaft with the brake assembly, is damaged. f) Air has mixed with hydraulic oil resulting in foamy oil.
Oil leaks.	<ul style="list-style-type: none"> a) Oil leaks from the motor flange are caused by a damaged O-ring seal on the motor flange. b) Oil leaks occurring between the cable drum flanges and housing are caused by excessive pressure in the brake housing. Excessive pressure in the brake housing will damage the oil seal between the brake housing and cable drum interior. c) If the breather relief on the end cover leaks, the seal between the drum interior and the brake housing is damaged and must be replaced. This condition is caused by excessive pressure in the brake housing of the winch, or operation with the incorrect hydraulic fluid during cold weather, or a restriction in the circulation return line leading back to tank.

Refer to the SERVICE INSTRUCTIONS if it becomes necessary to disassemble the Model M8 winch.

The Crosby Group, Inc.
P.O. Box 3128
Tulsa, OK 74101
(918) 834-4611

Copyright © 1997 The Crosby Group, Inc.
All Rights Reserved

P/N2010169
QF20M 10/97



**TERMINATOR
WEDGE SOCKET
WARNING AND APPLICATION
INSTRUCTIONS**

WEDGE SOCKET WARNINGS AND APPLICATION INSTRUCTIONS

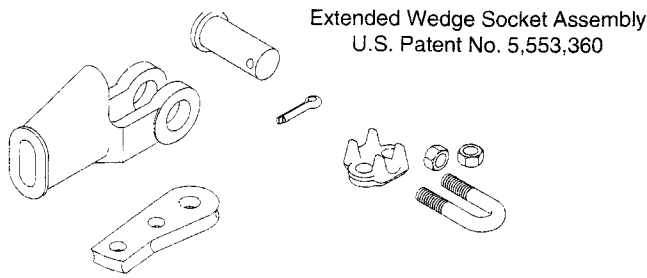

S-421T "TERMINATOR"™

NOTE: Existing Crosby S-421 Wedge Sockets can be retrofitted with the New Terminator Wedge.

New **QUIC CHECK™** "Go" and "No-Go" features cast into wedge. The proper size wire rope is determined when the following criteria are met: 1. The wire rope shall pass thru the "Go" hole in the wedge. 2. The wire rope shall NOT pass thru the "No-Go" hole in the wedge.



Important Safety Information - Read and Follow

Inspection/Maintenance Safety

- Always inspect socket, wedge and pin before using.
- Do not use part showing cracks.
- Do not use modified or substitute parts.
- Repair minor nicks or gouges to socket or pin by lightly grinding until surfaces are smooth. Do not reduce original dimension more than 10%. Do not repair by welding.
- Inspect permanent assemblies annually, or more often in severe operating conditions.

Assembly Safety

- Use only with standard 6 to 8 strand wire rope of designated size. For intermediate size rope, use next larger size socket. For example: When using 9/16" diameter wire rope use a 5/8" size Wedge Socket Assembly. Welding of the tail on standard wire rope is not recommended. The tail length of the dead end should be a minimum of 6 rope diameters but not less than 6" (See Figure 1).
- **To use with Rotation Resistant wire rope** (special wire rope constructions with 8 or more outer strands) ensure that the dead end is welded, brazed or seized before inserting the wire rope into the wedge socket to prevent core slippage or loss of rope lay. The tail length of the dead end should be a minimum of 20 rope diameters but not less than 6" (See Figure 1).
- Properly match socket, wedge and clip (See Table 1) to wire rope size.
- Align live end of rope, with center line of pin. (See Figure 1)
- Secure dead end section of rope. (See Figure 1)
- Tighten nuts on clip to recommended torque. (Table 1)
- Do not attach dead end to live end or install wedge backwards. (See Figure 2)
- **Use a hammer to seat Wedge and Rope as deep into socket as possible before applying first load.**

⚠ WARNING

- Loads may slip or fall if the Wedge Socket is not properly installed.
- A falling load can seriously injure or kill.
- Read and understand these instructions before installing the Wedge Socket.
- Do not side load the Wedge Socket.
- Apply first load to fully seat the Wedge and Wire Rope in the socket. This load should be of equal or greater weight than loads expected in use.

FIGURE 1

*Tail Length	
Standard 6 to 8 strand wire rope	Rotation Resistant Wire Rope
A minimum of 6 rope diameters, but not less than 6"	A minimum of 20 rope diameters, but not less than 6".

Rope Size	3/8	7/16	1/2	9/16	5/8	3/4	7/8	1	1 1/8	1 1/4
Clip Size	3/8	7/16	1/2	9/16	5/8	3/4	7/8	1	1 1/8	1 1/4
*Torque Ft./lbs.	45	65	65	95	95	130	225	225	225	360

* The tightening torque values shown are based upon the threads being clean, dry, and free of lubrication.

Figure 2

Operating Safety

- Apply first load to fully seat the Wedge and Wire Rope in the socket. This load should be of equal or greater weight than loads expected in use.
- Efficiency rating of the Wedge Socket termination is based upon the catalog breaking strength of Wire Rope. The efficiency of a properly assembled Wedge Socket is 80%.
- During use, do not strike the dead end section with any other elements of the rigging (Called two blocking).