

Operation and Maintenance Manual

Pipelay Wetdeck Package for 572E/F/G, 583H/K and 594G/H

S/N VEI 572E/F/G0021-UP
S/N VEI 583H/K0021-UP
S/N VEI 594G/H0021-UP

TO BE USED WITH CATERPILLAR
572E/F/G, 583H/K and 594G/H PIPELAYER OPERATION, LUBRICATION AND MAINTENANCE GUIDES



**VANGUARD EQUIPMENT, INC.
15627 EAST PINE ST
TULSA, OKLAHOMA
74116, USA**

 : **918.437.1796**

 : **918.437.1794**

TABLE OF CONTENTS

FOREWORD	1
MACHINE DESCRIPTION	1
SAFETY	1
WARNING SIGNS AND LABELS.....	1
GENERAL HAZARD INFORMATION.....	1
MACHINE PARKING	2
HIGH HYDRAULIC SYSTEM PRESSURE.....	2
<i>Equipment Lowering with Engine Stopped.....</i>	<i>3</i>
<i>Sound Information and Vibration Information</i>	<i>3</i>
Sound Level Information	3
Sound Performance for Machines that are Offered in European Union Countries and in Countries that Adopt the EU Directives.....	3
<i>"The European Union Physical Agents (Vibration) Directive2002/44/EC"</i>	<i>3</i>
<i>Guards</i>	<i>3</i>
<i>Daily Inspection.....</i>	<i>3</i>
COMPONENTS AND SPECIFICATIONS	4
MARK FOR EUROPEAN UNION	5
STANDARD FEATURES	5
OPTIONAL FEATURES	5
CABLE DRUM CAPACITIES	6
OVERALL WEIGHT AND DIMENSION OF PIPELAYER	6
DRAWWORKS CONTROLS.....	7
SPEED/LOCKOUT CONTROL LEVER	7
HOOK CONTROL LEVER	8
BOOM CONTROL LEVER	9
BOOM STOP VALVE.....	10
COUNTERWEIGHT CONTROL LEVER	10
HYDRAULIC OIL TEMPERATURE GAUGE	11
<i>Equipment Lowering with Engine Stopped.....</i>	<i>12</i>
MAINTENANCE AND LUBRICATION.....	13
GENERAL.....	13
LUBRICANT SPECIFICATIONS.....	13
REFILL CAPACITIES	13
SERVICE INTERVALS.....	14
<i>10 Hours Service Interval or Daily.....</i>	<i>14</i>
<i>50 Hours Service Interval or Weekly.....</i>	<i>14</i>
<i>200 Hours Service Interval or Monthly.....</i>	<i>14</i>
<i>500 Hours Service Interval or 3 Months.....</i>	<i>14</i>
<i>2000 Hours Service Interval or 1 Year.....</i>	<i>14</i>
HYDRAULIC SYSTEM OIL LEVEL CHECK	15
HYDRAULIC SYSTEM OIL SAMPLING.....	15
HYDRAULIC SYSTEM OIL CHANGE.....	16
HYDRAULIC SYSTEM OIL FILTER CHANGE.....	17
OIL FILTER INSPECTION.....	17
BOOM STOP VALVE ADJUSTMENT.....	18
BOOM STOP ROD SPRING ASSEMBLY INSPECTION AND REPAIR.....	20
HOOK AND WIRE CABLE – INSPECT	21
<i>Inspect the Hook.....</i>	<i>21</i>
<i>Inspect Wire Cable - Boom and Hook lines.....</i>	<i>21</i>
ACCUMULATOR.....	22
LIFTING OF COMPONENTS	22
TESTING AND ADJUSTING OF HYDRAULIC SYSTEM.....	23
HYDRAULIC SYSTEM IMPLEMENTATION	23
HYDRAULIC SYSTEM DISCHARGE	23
VISUAL CHECKS.....	24
PUMP EFFICIENCY CHECK	25

<i>Test on the Machine</i>	25
ACCUMULATOR TESTING AND CHARGING	26
<i>Identification of Charging Valves</i>	27
<i>Required Tools</i>	28
<i>Accumulators with Type 1 Valve</i>	30
Discharge Procedure.....	30
Testing and Charging Procedure for the Accumulator Precharge Pressure	31
<i>Accumulators with Type 2 Valve</i>	32
Discharge Procedure.....	33
Testing and Charging Procedure for the Accumulator Precharge Pressure	33
HYDRAULIC PUMP TESTING AND ADJUSTING	34
<i>Margin Pressure</i>	34
<i>Cutoff Pressure</i>	36
MAIN CONTROL VALVE	38
<i>Main Relief Valve</i>	38
<i>Pressure Reducing Valve (Pilot Circuit)</i>	41
<i>Load Sensing Manifold</i>	42
HOOK WINCH BRAKE MANIFOLD.....	44
<i>Hook Brake Release Pressure Testing and Adjusting</i>	45
<i>Hook Winch Counterbalance Valve</i>	46
BOOM-COUNTERBALANCE VALVE.....	47
BOOM STOP VALVE ADJUSTMENT	48
BOOM STOP PX-VALVE ADJUSTMENT.....	48
COUNTERWEIGHT RELIEF VALVE TESTING AND ADJUSTING.....	48
TROUBLESHOOTING.....	50
PROBLEM CHECKLIST.....	50
APPENDIX A: PULLMASTER WINCH CORPORATION – WINCH RIGGING ANCHOR PROCEDURES.....	54
APPENDIX B: PULLMASTER WINCHES.....	56
BOOM WINCH SERVICE INSTRUCTIONS – M30D-9-174-49-536	56
HOOK WINCH SERVICE INSTRUCTIONS – M30D-9-173-49D-522.....	65
BOOM WINCH TROUBLESHOOTING – M30D-9-174-49-536	75
HOOK WINCH TROUBLESHOOTING – M30D-9-173-49D-522.....	77
BOLT TORQUE CHART FOR PULLMASTER WINCHES.....	80

FOREWORD

Keep this manual with the machine in a safe, dry place where it is easily accessible, such as the toolbox.

Machine Description

The Vanguard Pipelayer Wetdeck package completely replaces the mechanical drawworks on Caterpillar 572G, 583K, and 594H pipelayers, converting them to hydraulic control. The wetdeck package does not decrease the tip characteristics of the original machine. Refer to machine's tip chart for load capacities and restrictions.

The operator should read, understand, and follow the wetdeck operating and maintenance instructions. The operator must follow and comply with all local pipelayer procedures, regulations, and safety precautions.

This equipment is to be operated by qualified personnel only.

The daily service/inspection procedure should be performed before start-up.

Operate all pipelayer controls with no load, until familiar with machine operation.

Note: Refer to the Caterpillar *Operator's Guide* for detailed information on the specific operation of the pipelayer not covered in this manual.

SAFETY

Certain conditions and precautions are peculiar to pipelaying operations. The following represents the minimum considerations for safe operations.

Warning Signs and Labels

Make sure that all of the warning signs are legible. Clean or replace the warning signs if you cannot read the words. Replace the illustrations if the illustrations are not visible. Use a cloth, water and mild soap to clean the warning signs. Do not use solvent, gasoline, or other harsh chemicals to clean the warning signs. Do not use pressure washers to clean the warning signs.

Replace any warning sign that is damaged, or missing. If a warning sign is attached to a part that is replaced, install a warning sign on the replacement part.

General Hazard Information

To prevent cable from slipping off the drum, a minimum of five full-wraps of cable must remain on the winch drum at maximum working extension of the hook or boom.

Follow pipelayer manufacture's guidelines for wire rope inspection and replacement.

Machine Parking



030-05-05-010B

Figure 1: Parking machine.

- Park on level surface. If necessary to park on a grade, block the machine.
- Apply the service brake to stop the machine.
- Lower any load to the ground.
- Refer to Caterpillar's pipelayer operation manual for the specific procedures regarding brake and transmission settings, engine shut down, and/or other implement attachments.

High Hydraulic System Pressure



029-09-09-005B

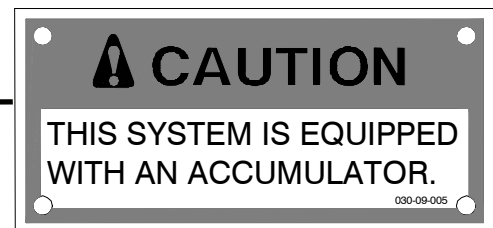

⚠ WARNING

TO AVOID PERSONAL INJURY, DO NOT REMOVE ANY HYDRAULIC SYSTEM LINES, TAPS OR PARTS UNTIL PRESSURE HAS BEEN RELIEVED.

TO RELIEVE PRESSURE:

1. STOP ENGINE.
2. MOVE THE HOOK CONTROL LEVER FROM "HOLD" TO "RAISE" 10 TIMES.

NOTE: ACCUMULATOR CYLINDER CHARGED WITH DRY NITROGEN (N₂) GAS.

SEE YOUR DEALER FOR CHARGING THE ACCUMULATOR.

THE ACCUMULATOR MUST BE AT THE SAME TEMPERATURE AS THE SURROUNDING AIR BEFORE BEING CHECKED OR CHARGED. USE THE CHART TO DETERMINE CORRECT ACCUMULATOR CHARGE, ± 70 kPa (10 psi):

TEMPERATURE	PRESSURE
-7°C (20°F)	3100 kPa (450 psi)
-1°C (30°F)	3170 kPa (460 psi)
4°C (40°F)	3240 kPa (470 psi)
10°C (50°F)	3310 kPa (480 psi)
16°C (60°F)	3375 kPa (490 psi)
21°C (70°F)	3445 kPa (500 psi)
27°C (80°F)	3515 kPa (510 psi)
32°C (90°F)	3580 kPa (520 psi)
38°C (100°F)	3650 kPa (530 psi)
43°C (110°F)	3720 kPa (540 psi)
49°C (120°F)	3790 kPa (550 psi)

030-09-001

Figure 2: High pressure warning decal; located on cover of counterweight valve on the right side of pipelayer.

The hydraulic implement system and some machine controls are "**LIVE**" for as long as the accumulator holds a charge, even if the engine is not running. This pressure charge will take approximately four hours or more to bleed off.

To relieve the accumulator charge, with no load on the hook and the engine stopped, move the *hook control* lever from "**HOLD**" to "**RAISE**" 10 times.

Always move the *speed control* lever to the "**LOCKED**" position before shutting off the engine or immediately after the engine quits running to prevent unintentional load release or, after the engine is restarted, drawworks operation.

NOTE: Refer to the SAFETY SECTION of the *Operator's Guide* of the specific pipelayer for additional information.

Equipment Lowering with Engine Stopped

Before lowering any equipment with the engine stopped, clear the area around the equipment of all personnel. The procedure will cause immediate, rapid lowering of the load. Wear appropriate personal protective equipment and follow the established procedure in the Operation and Maintenance Manual, "Equipment Lowering with Engine Stopped" in the Operation Section of the manual.

Sound Information and Vibration Information

Sound Level Information

Hearing protection may be needed when the machine is operated with an open operator station and an open cab for extended periods or in a noisy environment. Hearing protection may be needed when the machine is operated with a cab that is not properly maintained, or when the doors and windows are open for extended periods or in a noisy environment. Refer to the Caterpillar Operator's Guide for detailed information on the specific operating requirements.

Sound Performance for Machines that are Offered in European Union Countries and in Countries that Adopt the EU Directives

The Vanguard Pipelayer Wetdeck package completely replaces the mechanical drawworks on Caterpillar 572G, 583K, and 594H pipelayers, and as such does not affect the sound performance characteristics of the original Caterpillar pipelayer. Refer to the Caterpillar Operator's Guide for detailed information on the specific performance characteristics if applicable.

"The European Union Physical Agents (Vibration) Directive 2002/44/EC"

Refer to the Caterpillar Operator's Guide "The European Union Physical Agents (Vibration) Directive 2002/44/EC " for complete information concerning Whole Body Vibration Level if applicable.

Guards

There are different types of guards that are used to protect the operator.

A daily inspection of the guards is required in order to check for structures that are bent, cracked or loose. Never operate a machine with a damaged structure.

The operator becomes exposed to a hazardous situation if the machine is used improperly or if poor operating techniques are used. This situation can occur even though a machine is equipped with an appropriate protective guard. Follow the established operating procedures that are recommended for your machine.

Refer to the Caterpillar *Operator's Guide* for detailed information on the specific operation of the pipelayer not covered in this manual.

Daily Inspection

Refer to the Caterpillar *Operator's Guide* for detailed information on the specific daily inspection of the pipelayer.

After you inspect the machine, perform the daily maintenance that is listed in the Operation and Maintenance Manual, "Maintenance Interval Schedule". Perform the daily maintenance before you mount the machine in order to operate the machine.

COMPONENTS AND SPECIFICATIONS

Note: Number shown between { } indicates the hydraulic component identification as shown on the hydraulic schematic and on the wetdeck assembly

The wetdeck consists of the following components: winch and drive platform, drawworks operator controls, and a hydraulic tank. An optional oil cooler is also available.

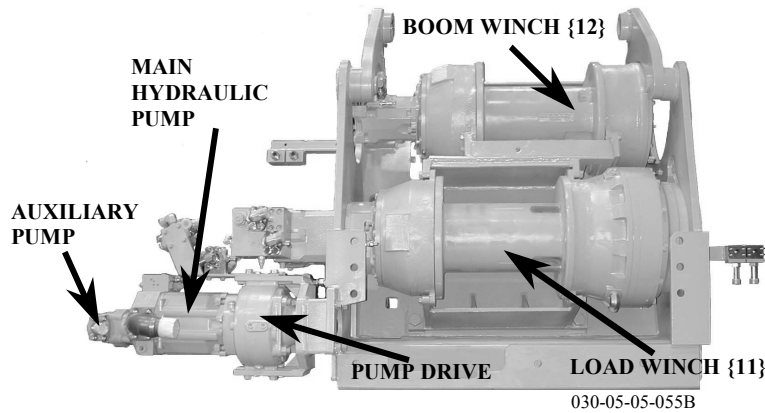

Figure 3: Winch platform.



Figure 4: Operator controls {7}.



Figure 5: Oil tank {2}.



Figure 6: Optional Oil Cooler {10}.

Mark for European Union

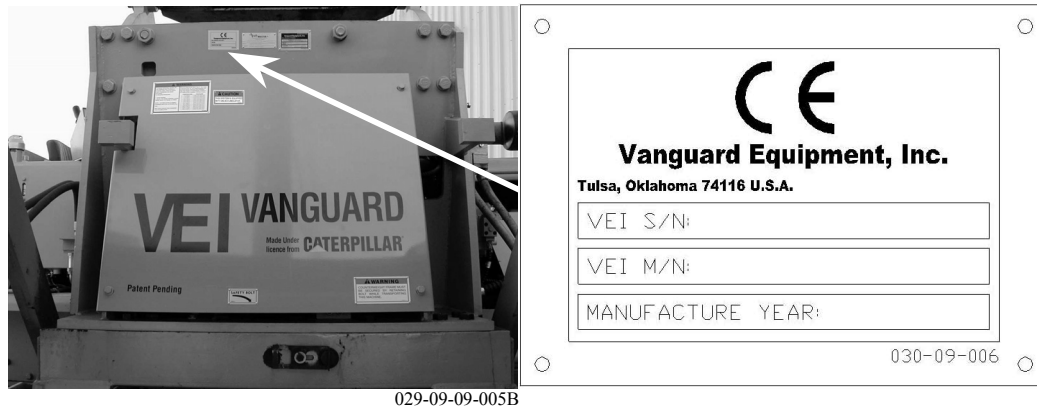

Figure 7: Location of the CE marking plate.

This plate is positioned above the right hand guard on the main weldment.

Standard Features

- Boom and hook drawworks are driven by independent hydraulic winches.
- Oil disc brakes provide positive retention of hook and boom positions.
- Variable speed controls for both hook and boom winches allow for precise control.
- Emergency free fall function on the load line allows the operator to drop the load quickly.
- 594 H only, standard 2-speed boom motor.

Optional Features

- 2-speed boom motor (572G and 583K only; standard on 594H).
- High temperature oil cooler.

Drawworks Equipment 572G/583K/594H		
	Hook	Boom
Planetary Hydraulic Winches		
Drum Diameter	254 mm (10 in)	254 mm (10 in)
Flange Diameter	457 mm (18 in)	457 mm (18 in)
Drum Length	432 mm (17 in)	432 mm (17 in)
Capacity – (19.05 mm (¾ in) rope diameter)	124m (407 ft)	124m (407 ft)

Nominal Line Speed, No Load 572G/583K/594H	Hook Speed	Boom Speed
Bare Drum	Hi: 91.4 m/min (300 ft/min) Low: 47.2 m/min (155 ft/min)	61 m/min (200 ft/min)
Optional Two-Speed Boom Motor, Bare Drum	Hi: 91.4 m/min (300 ft/min) Low: 47.2 m/min (155 ft/min)	Hi: 91.4 m/min (300 ft/min) Low: 47.2 m/min (155 ft/min)

Note: Refer to the *Operation And Maintenance Guide* of the specific pipelayer for additional information.

Cable Drum Capacities

Note: Refer to Caterpillar's Operator Guide for cable specifications.

To achieve optimum performance, use the wire rope length specified in the table below.

Optimum Rope Lengths for Maximum Lift Through Normal Operating Range		
572G	Wire Required for the Hook	Wire Required for the Boom
5.5 m (18 ft) Boom	48.8 m (160 ft)	41.1 m (135 ft)
7.3 m (24 ft) Boom	56.4 m (185 ft)	47.2 m (155 ft)

Optimum Rope Lengths for Maximum Lift Through Normal Operating Range		
583K	Wire Required for the Hook	Wire Required for the Boom
6.1 m (20 ft) Boom	64 m (210 ft)	51.8 m (170 ft)
7.3 m (24 ft) Boom	71.6 m (235 ft)	61 m (200 ft)

Optimum Rope Lengths for Maximum Lift Through Normal Operating Range		
594H	Wire Required for the Hook	Wire Required for the Boom
7.3 m (24 ft) Boom	93.3 m (306 ft)	57.9 m (190 ft)
8.5 m (28 ft) Boom	103 m (338 ft)	64 m (210 ft)
9.8 m (32 ft) Boom	112.8 m (370 ft)	70.1 m (230 ft)

Maximum Cable Drum Storage Capacities		
	Size	Length
Boom Line	19 mm ($\frac{3}{4}$ in)	124 m (407 ft) MAX
Load Line	19 mm ($\frac{3}{4}$ in)	124 m (407 ft) MAX

Notes:

- Using rope length longer than the optimum will decrease the drawworks' lifting capacity.
- Using rope length less than the optimum will decrease the operating envelope (load handling range of the pipelayer).

Overall Weight and Dimension of Pipelayer

The overall weight and dimension of the pipelayer are specified in the table below.

	Weight, Shipping (approximate)	Length	Height	Width
572	28 576 kg (63 000 lbs)	4.93 m (16 ft 2 in)	3.35 m (11 ft)	3.38 m (11ft 1.25 in)
583	41 731 kg (92 000 lbs)	5.66 m (18 ft 7 in)	3.12 m (10 ft 3 in)	3.66 m (12 ft)
594	56 246 kg (124 000 lbs)	5.79 m (19 ft)	3.76 m (12 ft 4 in)	4.29 m (14 ft 1 in)

DRAWORKS CONTROLS

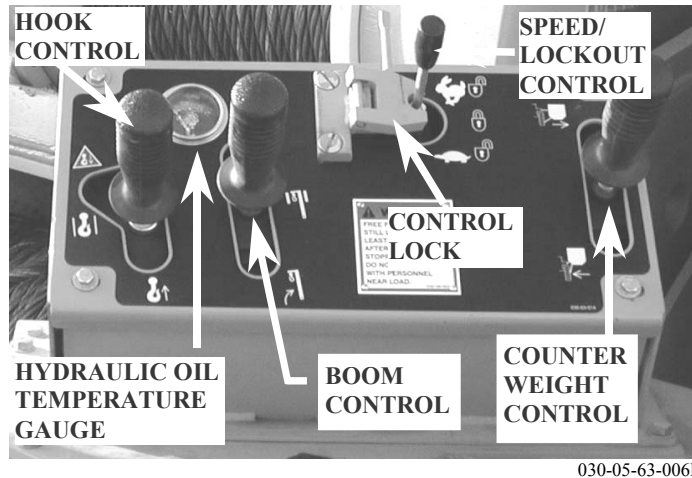

Figure 8: Drawworks control box {7}.

Speed/Lockout Control Lever

The position of the lever selects the load winch speed (high/low); on 594H machines, this control also selects the boom winch speed (high/low). The control is detented, and the lever will remain in position once released. It must be physically moved to the desired speed position.

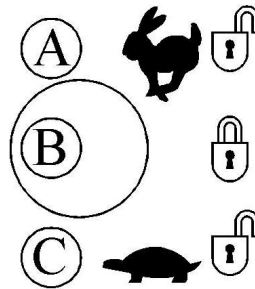





Figure 9: Speed control positions.

- A.  **HIGH SPEED MODE—WINCH CONTROLS UNLOCKED:** Move the lever to this position to operate the hook winch at high speed, the maximum hook winch pull is reduced; standard boom winch speed unaffected. **Note: 594H boom winch will also operate at high speed, reduced pull. 572G and 583K boom winches with the optional two-speed boom motor will also operate at high speed, reduced pull.**
- B.  **LOCKED MODE—WINCH AND COUNTERWEIGHT CONTROLS LOCKED:** To prevent accidental actuation of the controls while not in use, move the lever to this position and flip the control lock to engage the lever and lock it in position. In this mode, the winch and counterweight controls do not function. **Always** place the control lever in the LOCKED MODE **and** engage the Control Lock plate whenever the machine is left unattended, or when inadvertent control operation could result in a dangerous situation arising.
- C.  **LOW SPEED MODE—WINCH CONTROLS UNLOCKED:** Move the lever to this position to operate the load winch at low speed, maximum hook winch pull is available; standard boom winch speed unaffected. **Note: 594H boom winch will also operate at low speed, maximum pull. 572G and 583K boom winches with the optional two-speed boom motor will also operate at low speed, maximum pull.**

Hook Control Lever

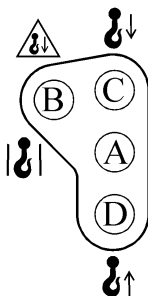



Figure 10: Hook control positions.

- A.  **HOLD:** The lever self-centers to this position whenever it is released. In this position, the load winch brake will set, and the hook will stop and remain at the position it is in.
- B.  **(EMERGENCY LOWER) Free Fall:**



Dropping load hazard! The free fall control remains live for several hours after the engine has been stopped. Operation of the free fall control could cause a sudden uncontrolled drop of any supported load. Do not operate the free fall control when personnel are near a suspended load, even with the engine stopped.



Figure 11: Free fall still live warning; located on wetdeck control box.

NOTE: The hydraulic pilot system and some machine controls, namely the hook Free Fall, are "LIVE" for as long as the accumulator holds a charge, even if the engine is not running. This pressure charge will take approximately four hours or more to bleed off. Refer to the operation and maintenance manual "Accumulator - Relieving Charge" to bleed off the residual pressure if required and when safe to do so.

! WARNING

Component failure! Re-engaging the free fall while the load is dropping causes shock loads which could cause component structural failure, resulting in possible personnel injury or death.





Free Fall Operation: Move the hook control lever to this position to lower the load fast in an emergency. The load winch's free fall brake will release, and the hook will move down under the weight of the load. Upon activating the free fall function the load will drop and must be allowed to fall to its end travel without re-engagement. The lever will return to the "HOLD" position when released, the load winch's free fall brake will set.

NOTICE

The Free Fall is used for a full release of a suspended load up to the maximum lift capacity of the hook winch. Upon activating the free fall function the load will drop and must be allowed to fall to its end travel without re-engagement.

Note: Free Fall is only available in pipelay high or low speed modes – winches unlocked.

- C.  **LOWER:** Move the lever to this position to lower the hook with controlled winch power. The further the lever is pushed away from "HOLD", the faster the hook will lower. The closer the lever is toward "HOLD", the slower the hook will lower. When the lever is released, it will return to the "HOLD" position, the load winch brake will set, and the hook will stop and remain at the position it is in. Load winch line speed varies with engine throttle setting. Hook control is smoothest at engine speeds faster than idle.

- D.  **RAISE:** Move the lever to this position to raise the hook. The further the lever is pulled away from "HOLD", the faster the hook will raise. The closer the lever is toward "HOLD", the slower the hook will raise. When the lever is released, it will return to the "HOLD" position and the hook will stop and remain at the position it is in. Load winch line speed varies with engine throttle setting. Hook control is smoothest at engine speeds faster than idle.

Boom Control Lever

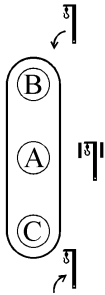





Figure 12: Boom control positions.

- A.  **HOLD:** The lever self centres to this position whenever it is released. In this position, the boom winch brake will set, and the boom will stop and remain at the position it is in.

- B.  **LOWER:** Move the lever to this position to lower the boom. The further the lever is pushed away from "HOLD", the faster the boom will lower. The closer the lever is toward "HOLD", the slower the boom will lower. When the lever is released, it will return to the "HOLD" position, the boom winch brake will set, and the boom will

stop and remain at the position it is in. Boom winch line speed varies with engine throttle setting. Boom control is smoothest at engine speeds faster than idle.

- C.  **RAISE:** Move the lever to this position to raise the boom. The further the lever is pulled away from "**HOLD**", the faster the boom will raise. The closer the lever is toward "**HOLD**", the slower the boom will raise. When the lever is released, it will return to the "**HOLD**" position, and the boom will stop and remain at the position it is in. Boom winch line speed varies with engine throttle setting. Boom control is smoothest at engine speeds faster than idle.

Boom Stop Valve



The Boom Stop system stops the boom winch from hauling-in when the boom is vertical, preventing overloading of key machine components. Defeating the boom stop valve could result in serious equipment damage, personnel injury, or even death. Its operation must be check and verified daily.

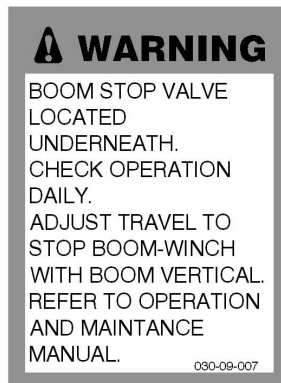

The Boom Stop valve is a safety device that is intended to automatically stop the boom winch from hauling-in when the boom is vertical, preventing overloading of key machine components. Refer to the Operation and Maintenance manual, Boom Stop Valve Adjustment, for correct operation and adjustment. Check its function daily.

Counterweight Control Lever

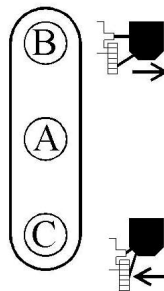



Figure 13: Counterweight control positions.

- A. **HOLD:** The lever self centers to this position whenever it is released. In this position, the counterweight will stop and remain at the position it is in.

- B.  **EXTEND:** Move the lever to this position to extend the counterweight. The further the lever is pushed away from "**HOLD**", the faster the counterweight will extend. The closer the lever is toward "**HOLD**", the slower the counterweight will extend. When the lever is released, it will return to the "**HOLD**" position, and the counterweight

will stop and remain at the position it is in. Counterweight speed varies with engine throttle setting. Counterweight control is smoothest at engine speeds faster than idle.

- C.  **RETRACT:** Move the lever to this position to retract the counterweight. The further the lever is pulled away from "HOLD", the faster the counterweight will retract. The closer the lever is toward "HOLD", the slower the counterweight will retract. When the lever is released, it will return to the "HOLD" position, and the counterweight will stop and remain at the position it is in. Counterweight speed varies with engine throttle setting. Counterweight control is smoothest at engine speeds faster than idle.

Hydraulic Oil Temperature Gauge



030-43-63-013A

TYPE 1 TEMPERATURE GAUGE



030-63-63-001

TYPE 2 TEMPERATURE

Figure 14: Oil Temperature Gauge.

The gauge indicates the temperature status of the drawworks' hydraulic oil.

Type 1 Temperature Gauge:

- A. **Green:** Normal operating temperature.
- B. **Red:** Critical temperature, stop the machine at a convenient place. Troubleshoot and rectify the cause. Allow oil to cool to normal range before continuing to use drawworks.

Type 2 Temperature Gauge : Maximum of 102°C (215°F) critical temperature, stop the machine at a convenient place. Troubleshoot and rectify the cause. Allow oil to cool to normal range before continuing to use drawworks.

Note: Continuing to operate the drawworks in the red (critical temperature) range could severely damage critical components, requiring a significant overhaul of the equipment.

Equipment Lowering with Engine Stopped

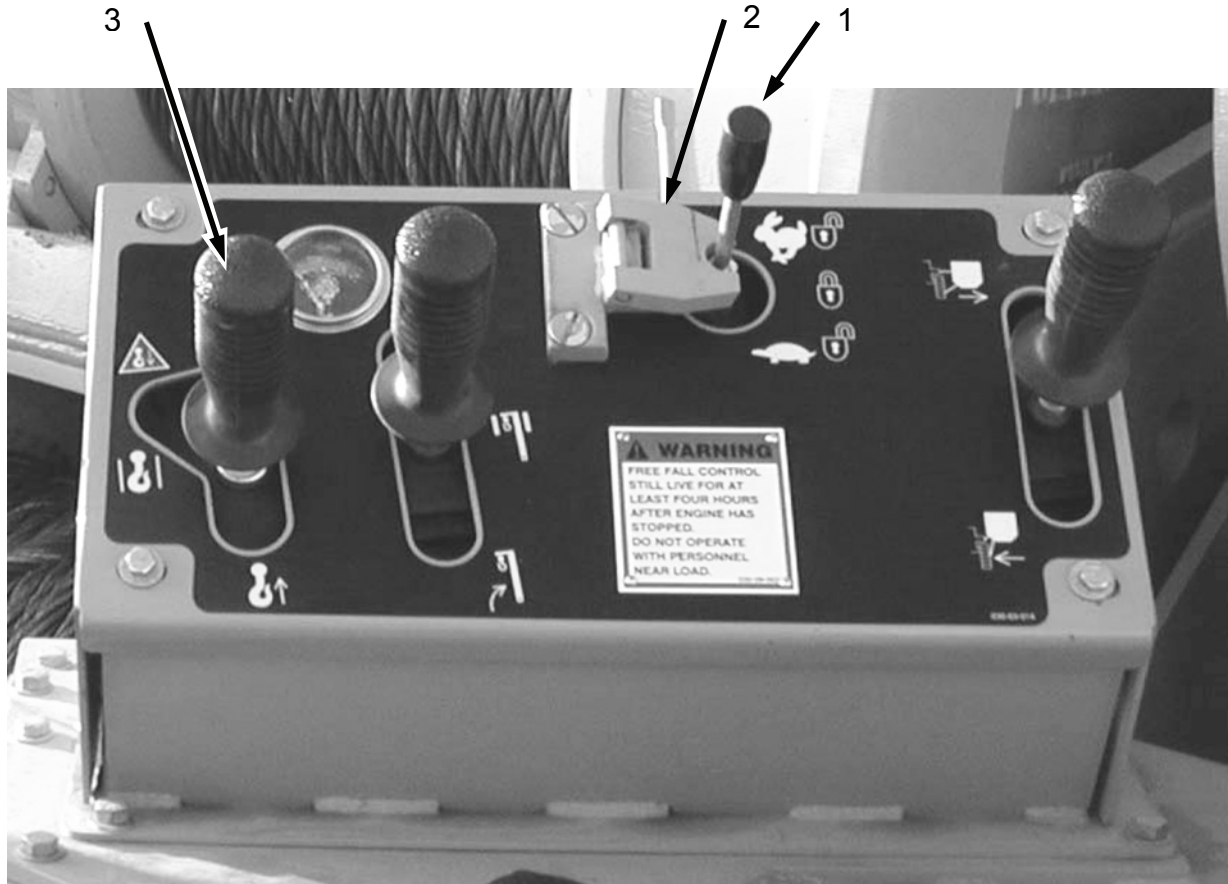

030-05-63-006B

Figure 15: Controls for Equipment lowering with engine stopped

NOTICE

Before lowering any equipment with the engine stopped, clear the area around the equipment of all personnel. The procedure will cause immediate, rapid lowering of the load. Refer to Operation and Maintenance Manual, "Hook Control" for complete control function description.

If the machine does not have engine power, in order to lower the equipment follow these steps:

- Unlock the Speed/Lockout Control Lock (2) and move the Speed/Lockout Control Lever (1) to LOW SPEED MODE—WINCH CONTROLS UNLOCKED or to HIGH SPEED MODE—WINCH CONTROLS UNLOCKED
- Move the hook control (3) to  (Emergency Lower) Free Fall.
- The accumulator will provide pilot pressure that will allow the hook to be immediately lowered fast under the weight of the load.
- Do not release the hook control to re-engage the Free Fall until the load is completely lowered.

MAINTENANCE AND LUBRICATION

Note: Number shown between { } indicates the hydraulic component identification as shown on the hydraulic schematic and on the wetdeck assembly.

General

- Follow pipelayer manufacture's maintenance and lubrication instructions for pipelayer service as required.
- Follow pipelayer manufacture's guidelines for wire rope inspection and replacement.
- To prevent corrosion damage to the winch interiors, if not used regularly, cycle the winches up and down several times at least once every two weeks.
- Care must be taken to ensure that fluids are contained during performance of inspection, maintenance, testing, adjusting, and repair of the product. Be prepared to collect the fluid with suitable containers before opening any compartment or disassembling any component containing fluids.
- Dispose of all fluids according to local regulations and mandates.

Lubricant Specifications

Note: Refer to Caterpillar *Material Safety Data Sheet (MSDS)* for appropriate handling and disposal procedure of fluid. MSDS for each particular fluid can be obtained from Caterpillar dealers or from the Caterpillar web site at www.cat.com.

System	Oil Viscosity	Ambient (outside) Temperatures			
		Min °C	Max °C	Min °F	Max °F
Gear Box	SAE 80W90	-30	+50	-22	+122
Hydraulic system	SAE 10W	-20	+40	-4	+104
	SAE 0W20	-40	40	-40	104
	SAE 0W30	-40	40	-40	104
	SAE 5W30	-30	40	-22	104
	SAE 5W40	-30	40	-22	104
	SAE 10W	-20	40	-4	104
	SAE 30	10	50	50	122
	SAE 10W30	-20	40	-4	104
	SAE 15W40	-15	50	5	122
	Caterpillar MTO	-25	40	-13	104
	TDTO-TMS ⁽²⁾	-20	50	-4	122

System	Caterpillar Oil Specification	Equivalent Oil Specification
Gear Box	GO	API GL-5
Hydraulic system	¹ HYDO, DEO, TDTO, MTO	² CG-4, CF-4, CF

Notes:

¹Use oil with appropriate viscosity depending on the ambient temperature

²These oils should have a minimum additive of 0.09 percent (900ppm).

Refill Capacities

System	Refill Capacities (approximate)		
	Liters	US Gal.	Imperial Gal.
Hydraulic system (includes tank)	208	55	45.8
Gear Box	2.4	0.63	0.53

Service Intervals

Note: Before each consecutive interval is performed, all maintenance from the previous interval must be performed. Perform the following servicing at EVERY interval they occur; for example, the 10 hour and 50 hour service are also performed at the 200 hour interval, etc.

10 Hours Service Interval or Daily

- Check hydraulic oil level.
- Check and repair any hydraulic system leaks. Inspect the hoses, the seals, the fittings, and the flanges for leaks.
- Inspect the winch final drive for leaks. Repair any final drive leaks.
- Inspect covers and the guards for damage, for loose bolts, and for missing bolts.
- Check controls for proper operation of boom and hook.
- Check boom stop valve for correct function.
- Hook and Wire Cable (Boom and Hook lines) – Inspect
- Inspect the hook for any distortion, bends, twists, etc. Inspect the hook for any wear, cracks, nicks, or gouges. Refer to American National Standard Institute ANSI/ASME B30.14, or ISO 8813.
- Check pipelayer structures and components for loose bolts, cracks, damage, etc.

50 Hours Service Interval or Weekly

- Thoroughly check boom stop system operation and adjustment, and inspect tractor's boom stop rod and spring assembly to ensure no rotation. Refer to the Boom stop Valve Adjustment procedure in the Maintenance and Lubrication section.

200 Hours Service Interval or Monthly

- Check oil level on gear box.

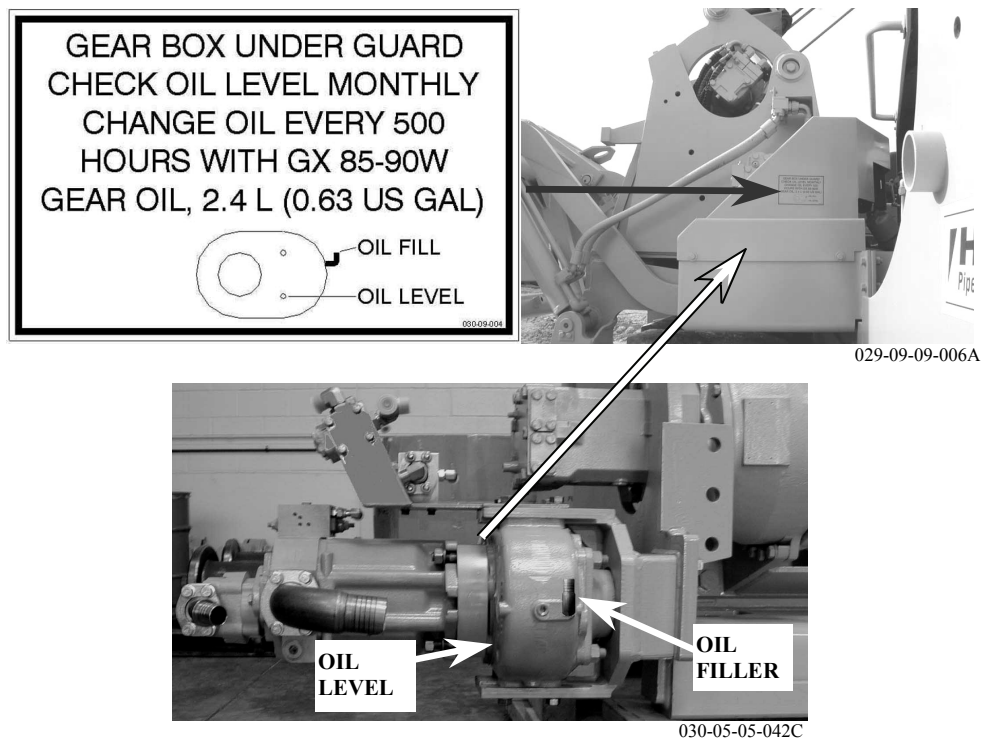

Figure 16: Gear box.

500 Hours Service Interval or 3 Months

- Change hydraulic system filter element.
- Change gear box oil (SAE 80W90).
- Analyze a hydraulic system oil sample for oil condition.

2000 Hours Service Interval or 1 Year

- * Change hydraulic system oil (SAE 10W).
- * Perform 500 hours service.

Hydraulic System Oil Level Check

! WARNING

At operating temperature, the hydraulic tank {2} is hot and under pressure. Hot oil and components can cause personal injury. Do not allow hot oil or components to contact skin. Remove the filler cap only when the engine is stopped, and the filler cap is cool enough to touch with your bare hand. Remove the filler cap slowly to relieve pressure.

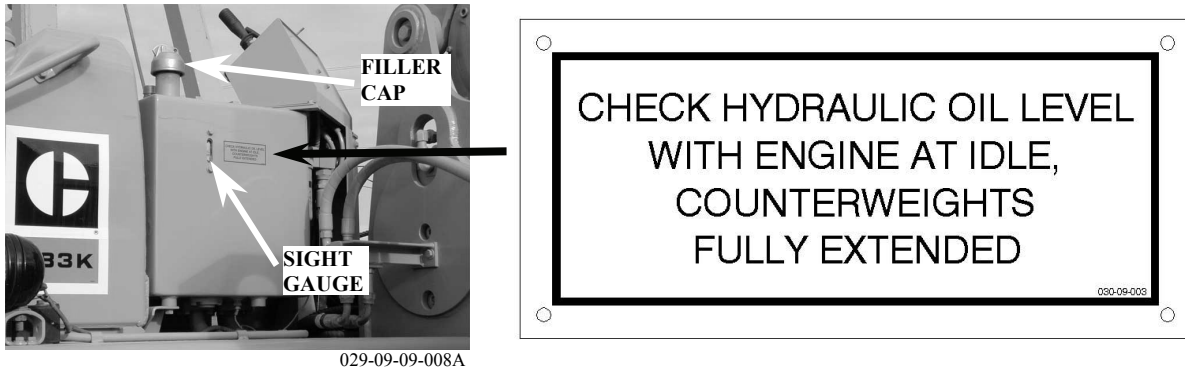

Figure 17: Hydraulic tank {2} components.

- * While the engine is at idle and counterweights fully extended, check the sight gauge. The oil level should be up to the “FULL” mark.
- * If the hydraulic system requires additional hydraulic oil, refer to the warning above. Carefully remove the filler cap to relieve pressure. With the engine running, add oil through the tank’s filler tube.
- * Clean the filler cap and inspect the seal. Replace the seal if damage or wear is evident.
- * Install and tighten the filler cap.

Hydraulic System Oil Sampling

! WARNING

At operating temperature, the hydraulic tank {2} is hot and under pressure. Hot oil and components can cause personal injury. Do not allow hot oil or components to contact skin. Remove the filler cap only when the engine is stopped, and the filler cap is cool enough to touch with your bare hand. Remove the filler cap slowly to relieve pressure.

- Operate the machine to ensure that the oil is warm and well circulated.
- Remove the hydraulic tank filler cap slowly in order to relieve any pressure.
- Using a clean oil sampling gun and a clean clear bottle, take an oil sample from the middle of the tank.
- Label the bottle with the sample date and the machine’s serial number.
- Send to a reputable lab for analysis.

Note: Ensure that the lab technician conducts the following: wear metal analysis; infrared analysis for oil condition; tests for contamination of the oil by fuel, by water, and/or by antifreeze; conducts a particle count.

Hydraulic System Oil Change

WARNING

At operating temperature, the hydraulic tank {2} is hot and under pressure. Hot oil and components can cause personal injury. Do not allow hot oil or components to contact skin. Remove the filler cap only when the engine is stopped, and the filler cap is cool enough to touch with your bare hand. Remove the filler cap slowly to relieve pressure.

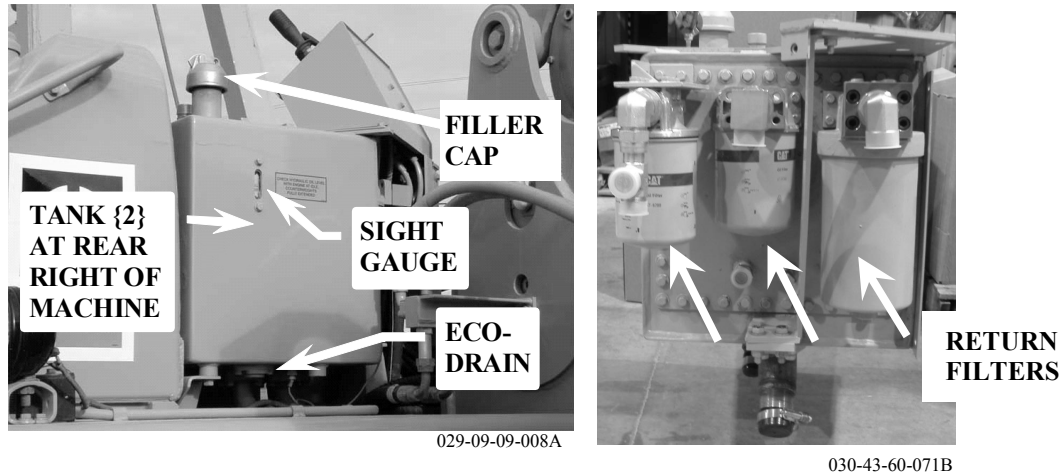

Figure 18: Hydraulic tank {2} components.

- Operate the machine in order to warm the oil.
- Park the machine on level ground. Lower any loads to the ground. Extend the counterweights. Move the speed selector to the locked position. Engage the control lock.
- * Refer to the warning above. Remove the hydraulic tank filler cap slowly in order to relieve any pressure.
- * Wash the filler strainer and the filler cap with clean nonflammable solvent.
- * Remove the oil eco-drain plug, located under the rear of the hydraulic tank {2}.
- * Attach a hose to a 1-inch NPT pipe nipple. This 1-inch NPT pipe nipple should have a length of 100mm (4 in).
- * Install the pipe nipple into the eco-drain plug opening.
- * Rotate the pipe nipple clockwise in order to open the internal drain valve. Allow the oil to drain into a suitable container.
- * Remove the pipe nipple. The valve for the hydraulic tank {2} will close.
- * Clean the ECO-drain plug and reinstall it; torque to 68±7 Nm (50±5 lb-ft).
- * Change the hydraulic system filter as per the Hydraulic System Oil Filter Change section.
- * Install the filler strainer.
- * Fill the hydraulic oil tank {2}; see the Lubricant Specifications section for oil type and quantity.
- * Inspect the filler cap gasket. Replace the gasket if damage or wear is evident.
- * Start the engine. Run the engine for a few minutes. **Note: Hydraulic oil must be checked with the engine running at idle and counterweights fully extended.**
- * Maintain the oil level at the “FULL” mark in the sight gauge. Adjust oil level as required.
- * Install and tighten the filler cap.
- * Retract counterweights.
- * Stop the engine.

Hydraulic System Oil Filter Change

WARNING

At operating temperature, the hydraulic tank {2} is hot and under pressure. Hot oil and components can cause personal injury. Do not allow hot oil or components to contact skin. Remove the filler cap only when the engine is stopped, and the filler cap is cool enough to touch with your bare hand. Remove the filler cap slowly to relieve pressure.

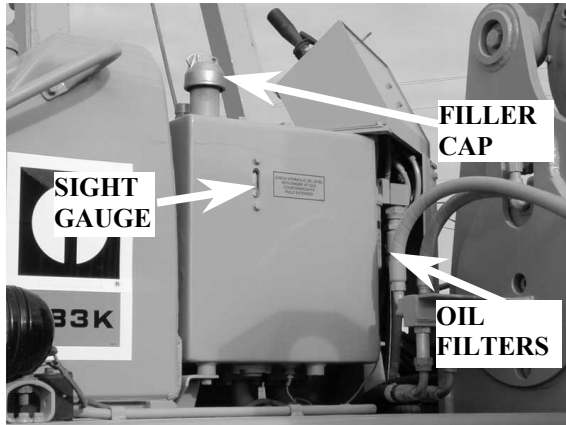

029-09-09-008A

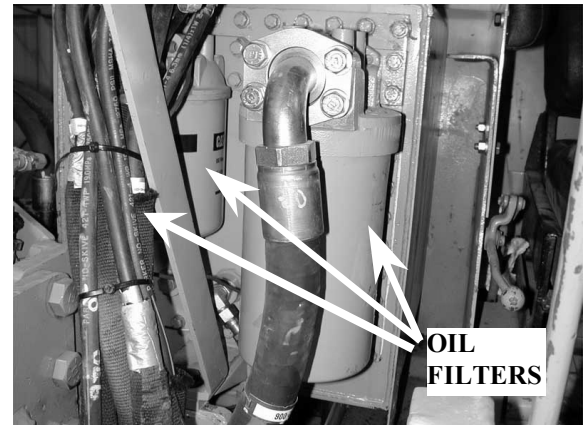

030-42-60-032A

Figure 19: Hydraulic system oil filter.

- * Refer to the warning above. Slowly remove the hydraulic tank filler cap in order to relieve the system pressure.
- * Remove the filter elements.
- * Apply a thin coat of oil to the seal on the new filter (two (2) small oil filters – CAT# 1-4T6788, large oil filter – CAT# 1-1R0741 and an O-ring – CAT# 5H3252).
- * Install the filter element by hand. When the seal contacts the base, tighten the filter element an additional $\frac{3}{4}$ turn.
- * Remove the retainer ring from the oil filter tube.
- * Wash the strainer in clean nonflammable solvent.
- * Inspect the seal on the filler cap. Replace the seal if damage or wear is evident.
- * Install the strainer, the retainer ring, and the cap.
- * While the engine is at idle and counterweights fully extended, check the oil level sight gauge.
- * Maintain the oil level at the “FULL” mark in the sight gauge. Adjust oil level as necessary.
- * Inspect the oil filter as outlined below.
- * After inspection, dispose of filter elements in an environmentally sound manner.

Oil Filter Inspection

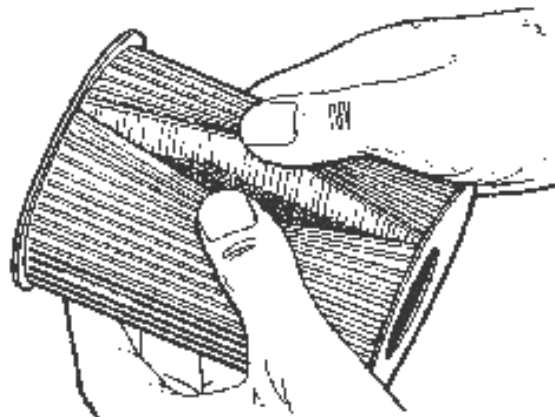

Figure 20: Oil filter.

Use a Filter Cutter - CAT# 4C-5084, or similar to cut the filter element open. Spread apart the pleats and inspect the element for metal and other debris. An excessive amount of debris in the filter element can indicate a possible failure.

If metals are found in the filter element, a magnet can be used to differentiate between ferrous metals and nonferrous metals. Ferrous metals would indicate wear on steel parts and on cast iron parts. Non ferrous metals would indicate wear of the brass or aluminum part of the hydraulics such as main bearings, pump sleeves, etc.

Small amounts of debris may be found in the filter element. This could be caused by friction and normal wear. Consult your Caterpillar dealer in order to arrange for further analysis if an excessive amount of debris is found.

Using an oil filter element that is not recommended by Caterpillar could result in severe damage. This could result in larger particles in unfiltered oil. These particles could enter the system and cause damage.

Boom Stop Valve Adjustment

WARNING

The Boom Stop system stops the boom winch from hauling-in when the boom is vertical, preventing overloading of key machine components. Incorrectly adjusting, or defeating the boom stop valve could result in serious equipment damage, personal injury, or even death. Its operation must be check and verified daily.

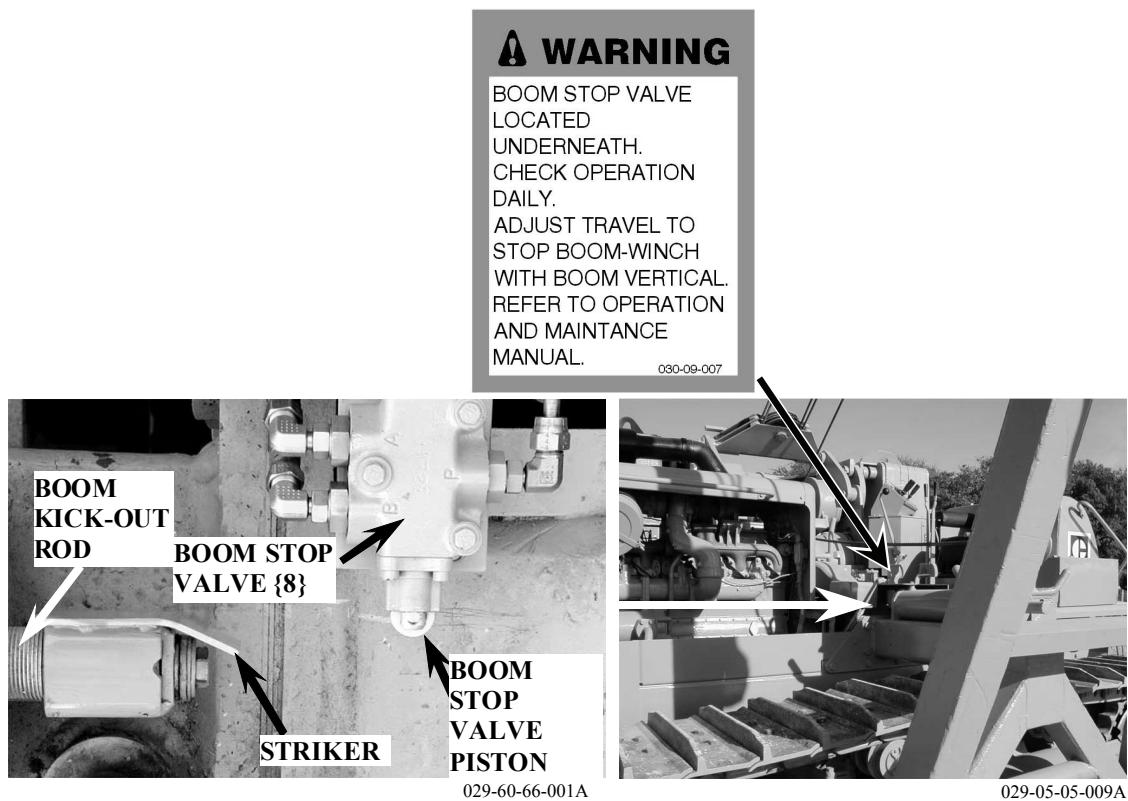

Figure 21: Boom stop valve {8} on platform of Pipelayer.

When properly adjusted, the boom stop valve {8} stops the boom winch {12} from hauling-in when the boom is vertical, preventing overloading of key machine components. When the boom engages the boom kick-out rod and moves the striker to actuate the cut-out valve piston, the boom stop valve {8} unloads the PX-valve in the boom section of the main control valve {5}. The unloaded PX-valve vents the main boom-up pressure line to tank, preventing the boom winch {12} from hauling-in and raising the boom further, preventing damage. When the boom is in its working range, the PX-valve is closed and any haul-in pressure is allowed to reach the boom winch {12}. **Check the operation of the boom stop system daily.**

NOTICE

The boom stop valve {8} is designed specifically for use with Caterpillar standard booms, as shipped with the original pipelayer machine. As many other boom types with very different physical dimensions exist, it is impossible to allow for all types. The following procedure may not include all adjustments that are required when using non-standard Caterpillar booms. Relocate the boom stop valve mounting plate as required to achieve the desired contact between the boom stop valve {8} and the boom kick-out rod—as outlined below—when the boom is vertical.

- Remove the boom stop valve guard.
- Loosen the cut-out valve {8} nuts.
- Raise the boom vertical to the pipelayer. The boom kick-out rod is fully retracted (all the way in). Do not over tighten the boom line to the point that the boom is overly stressed.
- Move the valve {8} so that its piston just contacts the boom kick-out striker.
- Move the valve an additional 9.5 mm (3/8 in) towards the boom.
- Tighten the valve {8} in position with the valve nuts.
- Test the boom stop valve {8} to see that it works properly. Lower the boom until the cut-out valve piston is free from striker.
- Boom in slowly taking care not to over tension the boom lines when the boom goes vertical. When the boom is vertical, the striker will move the cut-out valve piston in 9.5 mm (3/8 in), and the boom winch {12} should stop with the boom vertical, and no increase in tension should occur once; readjust the boom stop valve as required.
- Inspect the Boom stop Rod Spring Assembly as described below, adjust and repair as necessary.

Boom stop Rod Spring Assembly Inspection and Repair

! WARNING

If the tractor's spring assembly is worn or weak, normal operating vibration may cause rotation of the boom stop rod, and cause the wetdeck's cut-out striker-plate to rotate. If the wetdeck's boom stop striker plate rotates away and out of position from the hydraulic Boom stop valve, the operation of the hydraulic Boom stop system will be defeated. The Boom stop system stops the boom winch from hauling-in when the boom is vertical, preventing overloading of key machine components. Defeating the boom stop valve could result in serious equipment damage, personnel injury, or even death.

Check the tractor's boom stop rod for wear and rotation whenever the boom stop valve requires adjustment or during initial set-up.

1. Remove the guard covering the boom stop valve.
2. Ensure that the tractor's cut-out rod assembly (1) is in good working condition and not overly worn, and that the rod/striker-plate assembly (2) travels in a straight line—approximately $\pm 1/8$ -in (3.2 mm)—over its full stroke; repair the rod/tube assembly as required.
3. Ensure that the striker-plate (2) is aligned with the cut-out valve's actuation roller.
4. The castle nut (3) on the tractor's cut-out rod must be tightened to provide adequate spring compression—as per the original machine condition—to prevent the

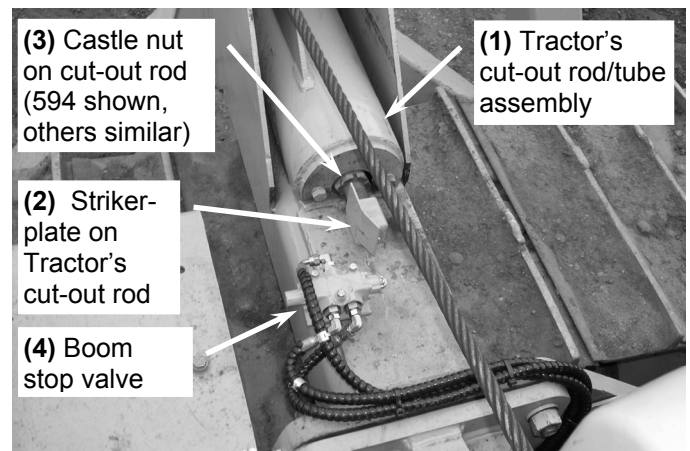
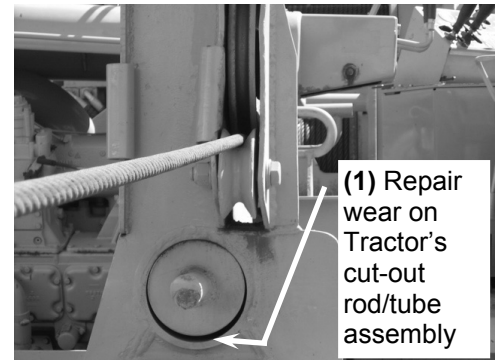

028-30-71-023

Figure 22: Boom stop Rod Spring Assembly Inspection and Repair.

5. Cut-out rod assembly from rattling and turning during normal machine operation; repair or replace worn tractor components as required. Ensure that the striker plate (2) does not rotate.
6. Ensure that the hydraulic Boom stop Valve (4) is correctly adjusted; follow the *Boom stop Valve Adjustment* procedure outlined above.
7. Machine operators must be fully aware of the function of the Boom stop system and the Speed/Lockout Control Lever (5). Check the correct operation of the Boom stop system as part of the daily machine safety inspection.

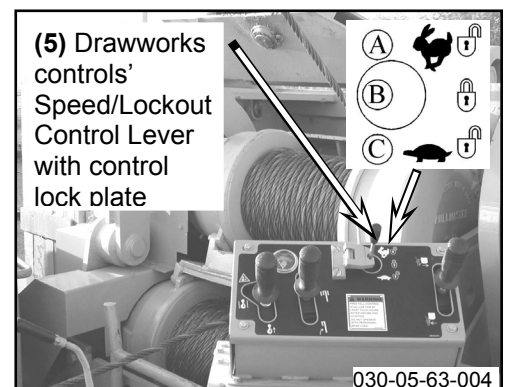

Figure 23: Boom stop system and the Speed/Lockout Control Lever (5).

Hook and Wire Cable – Inspect

Inspect the Hook

Inspect the hook frequently. The inspections should include observation of the hook during operation of the hook. A designated person determines if the conditions that are found during the inspections constitute a hazard. The designated person will determine if a more detailed inspection is required.

- Inspect the hook for any distortion such as bends in the hook or twists in the hook.
- Inspect the hook for any wear.
- Inspect the hook for cracks, nicks, or gouges.
- If a latch is provided, inspect the latch. Make sure that the latch engages properly. Inspect the latch for any damage. Make sure that the latch is not malfunctioning.
- Inspect the hook assembly and the means for securing the hook assembly.
- For additional information on the proper maintenance and on the proper inspection of hooks, refer to "American National Standard Institute ANSI/ASME B30.14".

Inspect Wire Cable - Boom and Hook lines

Make a visual inspection of all running cables that are in continuous use. Make the inspection of the running cables on a daily basis before the machine is placed in operation. Inspect all of the cables on a monthly basis.

All inspections shall be performed by a designated person. Keep a dated report of the condition of the cable on file in a location that is available to designated personnel. Perform a close inspection of the sections of the cable that are normally hidden during the visual inspection and the maintenance inspection. (This includes the sections of the cable that pass over the sheaves.) These points are the sections of the cable that are most likely to fail.

Note any deterioration that results in a notable loss of the original strength. (See the conditions that are described below.) Determine if further use of the cable will constitute a hazard.

Inspect the cable on a daily basis for the following conditions:

- Inspect the cable for a reduction in the diameter of the cable below the nominal diameter. A loss of support in the cored wire of the cable may be caused by internal corrosion, external corrosion, or wear of the outside wires.
- Inspect the cable for broken outside wires. Check for the degree of distribution of the broken outside wires. Check for the concentration of outside broken wires.
- Inspect the cable for worn outside wires.
- Inspect the cable for corroded wires and for broken wires at the connection on the wire cable end.
- Inspect the cable end for connections that are corroded, cracked, bent, worn, or improperly installed.
- Inspect the cable for sections that are crushed or kinked and for any loose wire strands.

Excessive wear or broken wires may occur in sections of the cable that are in contact with saddles, equalizer sheaves, or other sheaves. Excessive wear or broken wires can also occur when cable travel is limited. Take care to inspect the ropes at these locations.

When a machine is shutdown for a month or more, inspect all of the cables thoroughly. When a side boom machine has been in storage for a month or more inspect all of the cables thoroughly. The inspection should be completed before the machine is returned to operation.

The inspection should be for all types of deterioration. The inspection should be performed by a designated person or by an authorized person. The authorized person's approval is required for further use of the cable.

A dated report on the condition of the cable should be kept on file.

Take care in the inspection of cable that is resistant to rotation.

Any new poured socket or swaged socket assembly that is used as a standing cable (guy) shall be proof tested. Test the cable to the lift capacity of the side boom machine or to the manufacturer's recommendation.

Never give the cable a rating that is greater than 50 percent of the wire rope's nominal strength or of the structural strand's nominal strength.

Note: For additional information on the proper maintenance and on inspection of the cable, refer to "American National Standards Institute ANSI/ASME B30.14" or ISO 8813.

Accumulator

Accumulator {9} must be charged with dry nitrogen (N₂) gas by qualified personnel only, refer to Accumulator Testing and Charging section.

Lifting of Components



Improper lifting can allow load to shift and cause serious injury or damage.

The main structure weighs approximately 2903 kg (6400 lb). Use proper belt slings – one around the boom winch drum and one around hook winch drum – that can support the weight of the main structure; position in such a way that the drawworks are properly balanced when lifted.

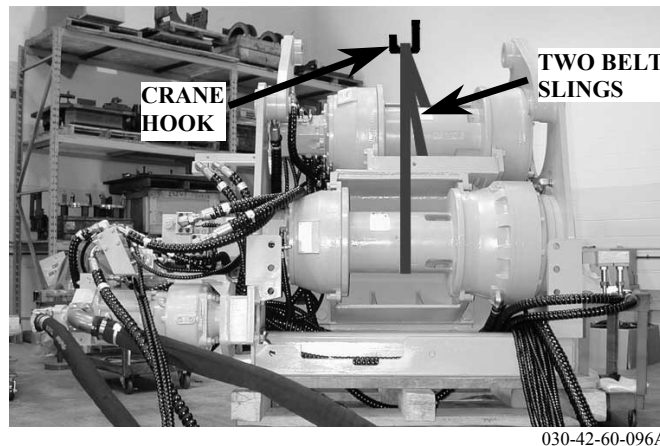

030-42-60-096A

Figure 24: Lifting of the main structure.

The hydraulic tank {2} weighs approximately 408 kg (900 lbs). Use proper chains to lift the tank {2}. Two 3/8-inch, NC, 1-inch long eyebolts are required as lifting lugs. One eyebolt (closest to the fill port) screws directly into the tank {2}. The other eyebolt is secured into the lifting hole, diagonally opposite the fill port, with a 3/8-inch, NC, nut and washer.

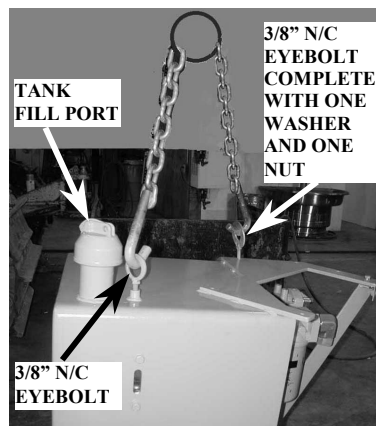

030-60-60-007B

Figure 25: Lifting of the hydraulic tank {2}.

TESTING AND ADJUSTING OF HYDRAULIC SYSTEM

Hydraulic System Implementation



Sudden movement of the machine or release of oil under pressure can cause serious injury to persons on or near the machine.

1. Move the machine to a smooth horizontal location. Move away from working machines and personnel. Lower any suspended load to the ground and lower the boom to the ground.
2. Allow only one operator on the machine. Keep all other personnel away from the machine or in view of the operator.
3. Engage the parking brake and stop the engine.
4. Move the hook control lever to the RAISE and HOLD positions several times in order to release pressure in the hydraulic system. Refer to the High Hydraulic System Pressure section.



At operating temperature, the hydraulic tank {2} is hot and under pressure. Hot oil and components can cause personal injury. Do not allow hot oil or components to contact skin. Remove the filler cap only when the engine is stopped, and the filler cap is cool enough to touch with your bare hand. Remove the filler cap slowly to relieve pressure. Ensure that the oil temperature is cool before removing lines or components.

5. Carefully loosen the filler cap on the hydraulic tank {2} in order to release the pressure in the tank.
6. Ensure that all of the hydraulic pressure is released before any fittings, hoses or components are loosened.
7. Tighten the filler cap on the hydraulic tank {2}.
8. The pressure in the system has now been released and the lines and components can be removed.



029-09-09-005B

Figure 26: Main hydraulics guard/access panel. Located on right of machine behind counterweights.

Hydraulic System Discharge



Pressurized fluids can cause injury or death. Before disassembling any lines, controls, or the accumulator {9}, ensure that the pilot system hydraulic accumulator pressure is zero.

Discharge the hydraulic pilot pressure as follows:

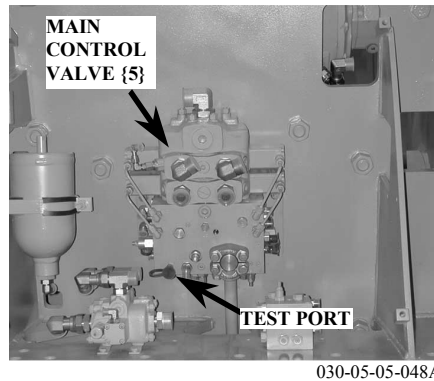

Figure 27: Location of the pressure test port for the accumulator {9} on main control valve {5}.

1. Attach a 0 to 7000kPa (0 to 1000psi) pressure gauge to the pressure test port via the quick-disconnect coupling. This port is on the main control valve {5}.

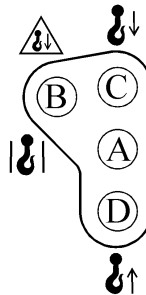

Figure 28: Hook control positions.

2. Move the hook control lever to the raise position (D), and back to the HOLD position (A). Repeat this procedure several times.
3. The needle on the pressure gauge should quickly drop to zero.
4. If the gauge does not show any pressure, the pilot pressure has been discharged.

During a diagnosis of the hydraulic system, remember that the correct oil flow and pressure are necessary for correct operation. The output of the pump {1} may increase with an increase in engine speed. Oil pressure is caused by a resistance to the output or oil flow.

Visual Checks

A visual inspection of the hydraulic system and the corresponding components is the first step in order to identify a problem. Make the following inspections.

! WARNING

The boom must be raised and lowered through its full arc to test the hydraulics. To avoid personal injury, perform this test in an area with sufficient boom clearance. Be especially aware of any potential electrical power line contact. Ensure area is free of personnel. Prevent machine movement by applying the parking brake, block the machine if necessary.

Personal injury or death can result from escaping fluid under pressure. Escaping fluid under pressure, even a very small pin-hole size leak, can penetrate body tissue and cause serious injury and possible death. If fluid is injected into your skin, it must be treated immediately by a doctor familiar with this type of injury. Always use a board or cardboard when checking for a leak.

Note: Remove only the appropriate guards and covers necessary to gain access to the hydraulic component to be tested/adjusted. Replace guards/covers when access to components is no longer required, or when protection from possible component failure is required prior to activating the system.

1. Check all of the implement oil line connections for damage or leaks.
2. Trace all of the oil lines from the implement connections to the valve connections. Check the lines and the connections for damage or leaks.
3. Check the pump {1} and the connections for damage or leaks.
4. Trace the pump lines to the tank {2} and the valves. Check the lines and the tank {2} for damage or leaks.
5. Check the oil level in the tank {2}.
6. Use a clear bottle or a container in order to get an oil sample immediately after the machine is stopped. Check for air bubbles in the oil sample.
7. Remove the filter element and check for particles in the filter. A magnet can be used in order to separate ferrous material from the nonferrous particles in the filter; see Oil Filter Inspection section.

Pump Efficiency Check

This test is designed to determine if a pump is operating within the design parameters.

For any pump test, the pump flow at 690 kPa (100 psi) will be greater than the pump flow at 6900 kPa (1000 psi), for the same pump rpm. The pump flow is measured in L/min or US gpm.

The difference between the pump flow of two operating pressures is the flow loss.

Method for determining flow loss
$\begin{array}{r} \text{Pump flow at 690 kPa (100 psi)} \\ - \text{Pump flow at 6900 kPa (1000psi)} \\ \hline \text{Flow loss} \end{array}$

Example of determining flow loss
$\begin{array}{r} 217.6 \text{ L/min} \\ -196.8 \text{ L/min} \\ \hline 20.8 \text{ L/min} \end{array} \quad \text{or} \quad \begin{array}{r} 57.5 \text{ US gpm} \\ -52.0 \text{ US gpm} \\ \hline 5.5 \text{ US gpm} \end{array}$

Flow loss is used as a measure of pump performance. Flow loss is expressed as a percentage of pump flow.

Method of determining percent of flow loss
$\frac{\text{Flow loss (L/min or US gpm)} \times 100}{\text{Pump flow at 690 kPa (100 psi)}}$

Example of determining percent of flow loss
$\frac{20.8 \text{ L/min} \times 100}{217.6 \text{ L/min}} = 9.5\% \quad \text{or} \quad \frac{5.5 \text{ US gpm} \times 100}{57.5 \text{ US gpm}} = 9.5\%$

If the percent of flow loss is greater than 10%, the pump performance is inadequate.

Note: The values in the examples are not set values for any specific pump or for any specific pump condition (Refer to the Caterpillar Hydraulic specifications, RENR2028 for the pump flow of a new pump at 690 kPa (100 psi) and at 6900 kPa (1000 psi)).

Test on the Machine

Install a flow meter according to the manufacturer's instructions. Run the engine at high idle. Measure the pump flow at 690 kPa (100 psi), and at 6900 kPa (1000psi). Use these values in the following formula.

Method of determining percent of flow loss

$$\frac{\text{Flow loss (L/min or US gpm)} \times 100}{\text{Pump flow at 690 kPa (100 psi)}}$$

Replace or rebuild the pump {1} if the percent loss is greater than 10%.

Accumulator Testing and charging

! WARNING

This system contains high pressure gas. Failure to follow the instructions and warnings could cause an explosion, resulting in possible injury or death. Do not expose to fire. Do not weld. Do not drill. Do not remove any hydraulic system lines, taps or parts until pressure has been relieved. Relieve pressure before discharging. See Operation and Maintenance Manual "Hydraulic System Discharge". See Operation and Maintenance Manual "Accumulator" for charging and discharging. See your Dealer for tools and detailed information.

Accumulator {9} must be charged with dry nitrogen (N₂) gas by qualified personnel only.

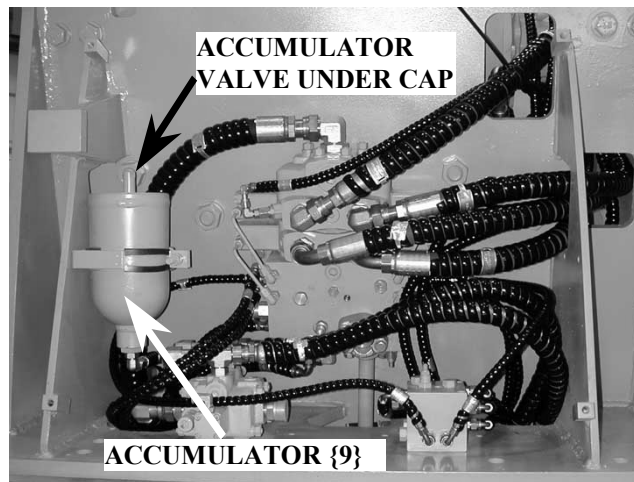

029-60-66-001A

Figure 29: Accumulator {9} location.

! WARNING

Dry Nitrogen is the only gas approved for use in the accumulator {9}. Charging the accumulator {9} with oxygen gas will cause an explosion. This danger will not happen if nitrogen cylinders with standard CGA (Compressed Gas Association, Inc.) number 580 connections are used. When you order nitrogen gas, be sure that the cylinders are equipped with CGA No. 580 connections. Do not use color codes or other methods of identification to tell the difference between nitrogen and oxygen cylinders.

Accumulator must be charged with dry nitrogen (N₂) gas by qualified personnel only. Gas pressure varies with the temperature. The accumulator {9} must be at the same temperature as the surrounding air before the accumulator {9} can be checked or charged. Check figure below to determine the correct accumulator charge.

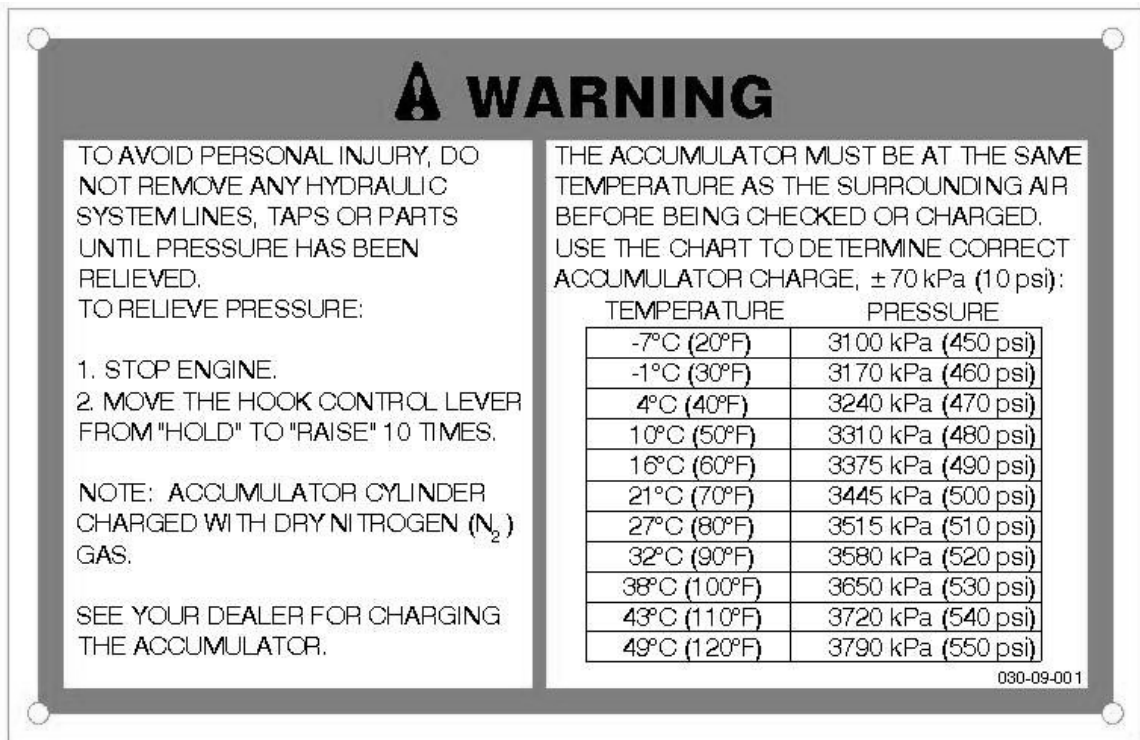

Figure 30: Accumulator high pressure warning and charge decal; located on main guard cover on the right-hand side of pipelayer.

Do not use an adapter to connect the nitrogen charging equipment to a valve that can be used on oxygen cylinders or gas cylinders. **Use dry nitrogen only.**

The pressure of the hydraulic oil on the accumulator {9} must be relieved before the accumulator {9} is tested or charged. Shut off the engine and perform the procedure to discharge the accumulator {9}. See the Hydraulic System Discharge section.

Identification of Charging Valves

Identification of the charging valve is critical for safe discharging of the accumulator. Charging valves on Vanguard equipment include the following types:

TYPE 1: This type of valve is a standard Schrader valve. This valve is opened by depressing a spring-loaded core (1) with the charging chuck of the nitrogen charging equipment.

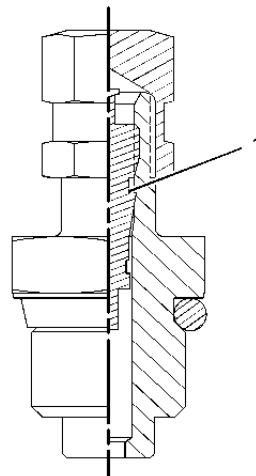

Figure 31: Type 1 accumulator discharge valve

TYPE 2: This type of valve is larger than the type 1 and has 28 mm threads (2). This valve is opened by turning a screw (3) which is contained in the valve body.

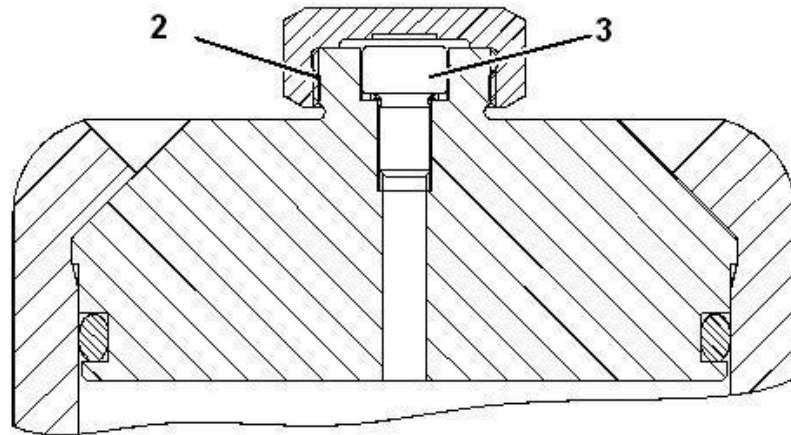

Figure 32: Type 2 accumulator discharge valve

Required Tools

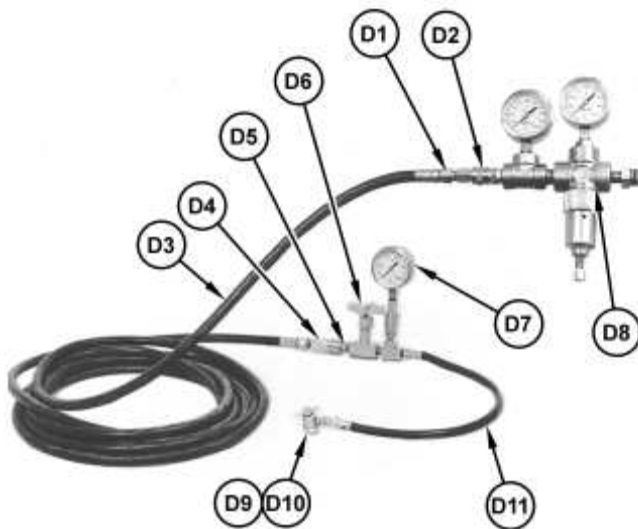

Figure 33: Type 1 Nitrogen charging apparatus

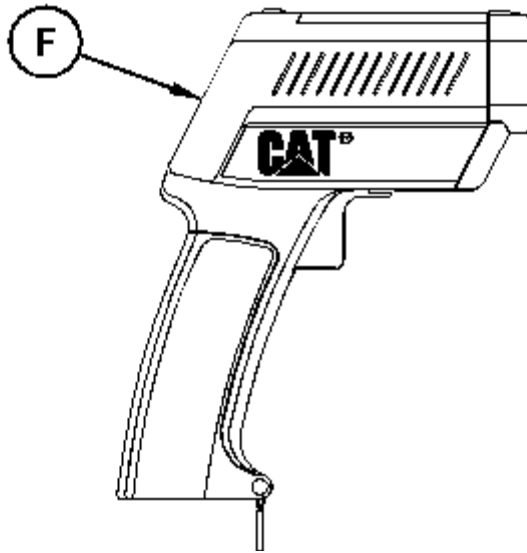

Figure 34: Thermometer

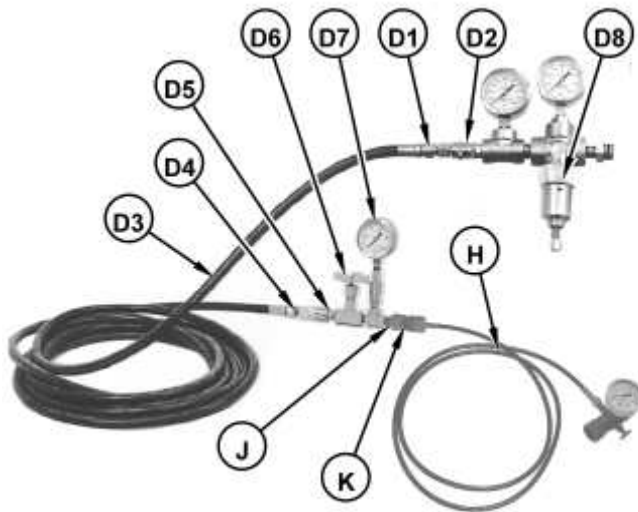

Figure 35: Type 2 Nitrogen charging apparatus

Tools Needed			
	CAT Part Number	Part Description	Quantity
Tool = D	175-5507	Nitrogen Charging Apparatus	1
Item		CONSISTS OF:	
D1	8S-4600	Fitting	1
D2	8S-1506	Coupling As	1
D3	162-4147	Hose As	1
D4	8S-4599	Coupling As	1
D5	2S-5244	Fitting	1
D6	1S-8937	Needle Valve	1
D7	8T-0859	Pressure Gauge	1

		(0 to 25,000 kPa (0 to 3,600 psi))	
D8	162-4146	Regulator	1
D9	7S-5106	Chuck	1
D10	1S-8938	Chuck	1
D11	1S-8941	Hose As	1
Tool = F	349-4200	Thermometer	
Tool = H	9U-6740	Accumulator Charging Group	
Tool = J	334-1071	Adapter	
Tool = K	9U-6741	Adapter	

Accumulators with Type 1 Valve

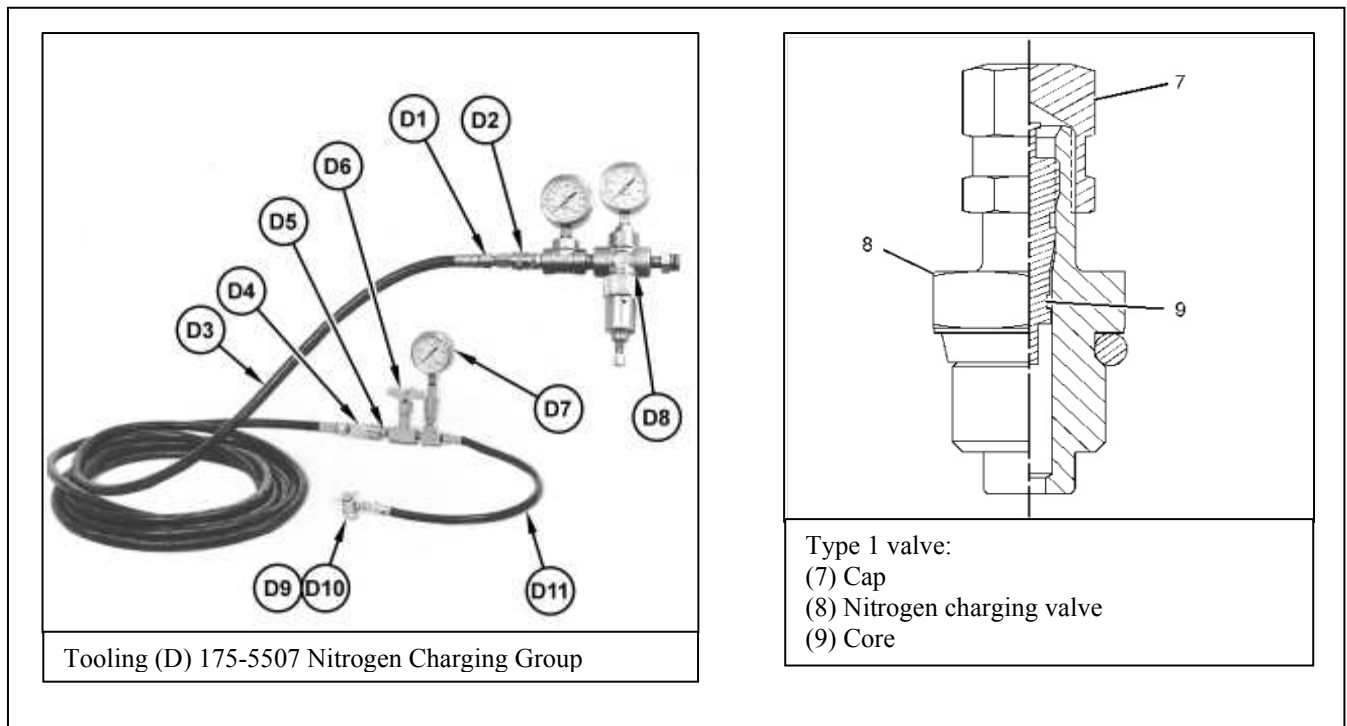

Figure 36: Type 1 Valve references

Discharge Procedure

1. Identify the correct nitrogen charging chuck.
2. Attach hose assembly (D11) to nitrogen charging chuck (D9 or D10).
3. Turn valve handle of nitrogen charging chuck (D9 or D10) all the way in the counterclockwise direction.

Note: Turning the valve handle will ensure that nitrogen charging valve (8) will not be opened when nitrogen charging chuck (D9 or D10) is attached.

4. Remove cap (7) from nitrogen charging valve (8).
5. Attach nitrogen charging chuck (D9 or D10) to nitrogen charging valve (8).
6. Turn valve handle of nitrogen charging chuck (D9 or D10) in the clockwise direction in order to open nitrogen charging valve (8). Turning the valve handle will release all of the nitrogen from the accumulator through hose assembly (D11).

Testing and Charging Procedure for the Accumulator Precharge Pressure

Note: Test the accumulator precharge pressure when the machine is not running and all pressure has been released from the hydraulic system. Refer to the Hydraulic System Discharge section in the Operation and Maintenance Manual.

1. On the accumulator, remove cap (7) on nitrogen charging valve (8).
2. Identify correct nitrogen charging chuck (D9 or D10).
3. Turn the valve handle of nitrogen charging chuck (D9 or D10) all the way in the counterclockwise direction.
4. Attach nitrogen charging chuck (D9 or D10) and hose assembly (D11) to nitrogen charging valve (8).
5. Attach hose assembly (D11) between nitrogen charging chuck (D9 or D10) and the tee. Install needle valve (D6) to the tee. Refer to Figure 36. Install pressure gauge (D7) in the remaining open port on the tee.
6. Turn the valve handle for needle valve (D6) all the way in the clockwise direction. Completely turning the valve handle will ensure the needle valve (D6) is closed.
7. Turn valve handle of nitrogen charging chuck (D9 or D10) in the clockwise direction in order to open nitrogen charging valve (8).
8. Read pressure gauge (D7) in order to determine the charge pressure in the accumulator. If charging is needed, attach regulator (D8) to a nitrogen tank.
9. Adjust pressure regulating screw on the regulator to obtain the correct pressure reading on the gauge, refer to Figure 30 for the correct pressure reading based on temperature. Use tooling (F) to determine the correct temperature.

Note: If the machine has been running for some time, the temperature of the accumulator may be different from the ambient temperature of the outside air. Use tooling (F) to determine the current temperature of the accumulator.

10. Open needle valve (D6). Nitrogen will flow from the regulator to the accumulator. When gauge (D7) reads the correct pressure, close needle valve (D6).
11. Allow the temperature of the accumulator to stabilize. Recheck the precharge pressure at the stabilized temperature.
12. Once the accumulator is charged, turn the valve handle of chuck (D9 or D10) counterclockwise completely. Remove chuck (D9 or D10). Remove the regulator from the nitrogen tank.

Accumulators with Type 2 Valve

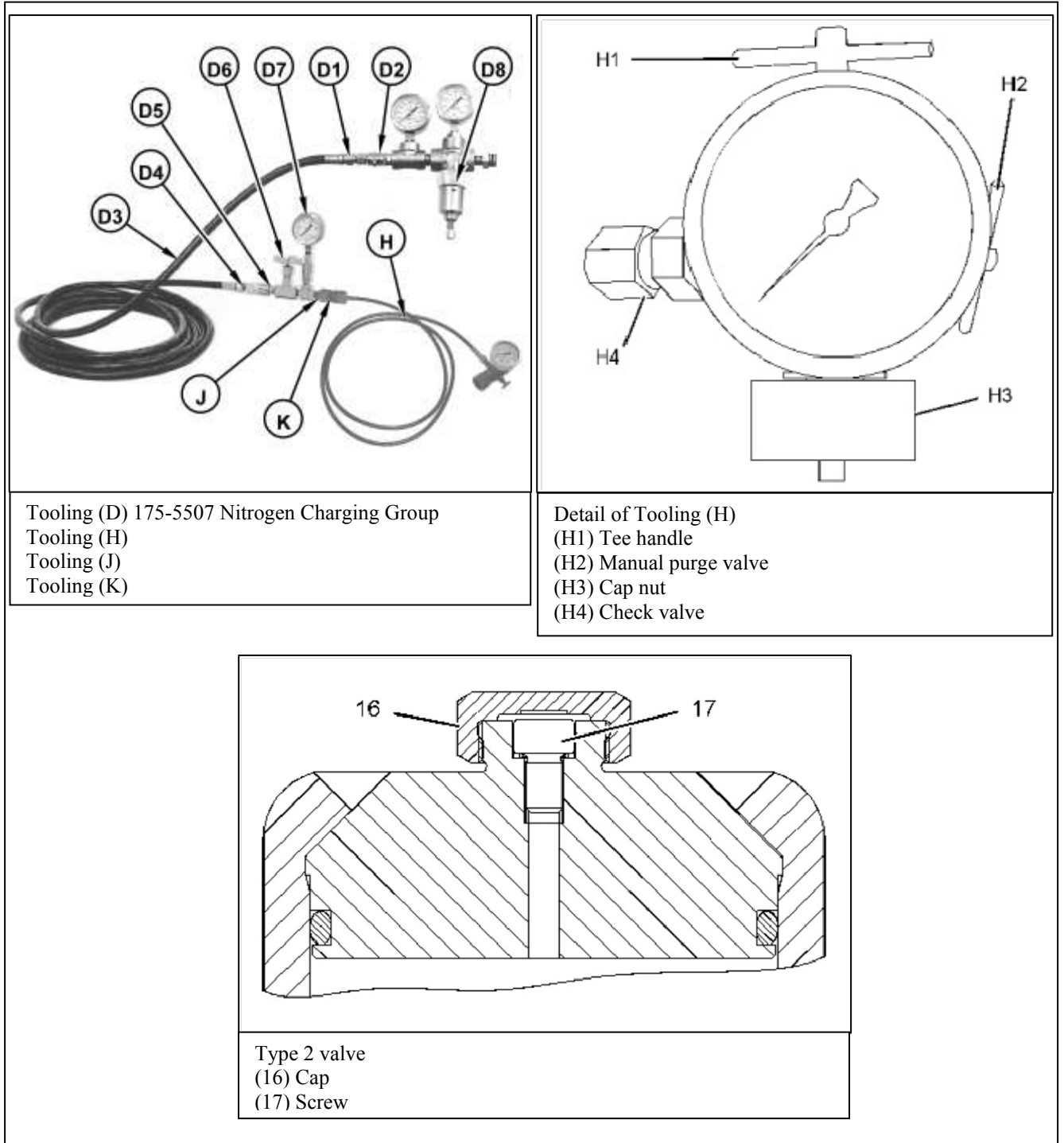

Figure 37: Type 2 Valve references

Discharge Procedure

1. Turn manual purge valve (H2) in the clockwise direction to close the purge valve.
2. Remove cap (16) from charging valve. In many cases, Tooling (H) will not be able to apply enough force to break loose vent screw (17). If necessary, use an Allen wrench to break loose and retighten the vent screw. Turn the vent screw counterclockwise to loosen the screw.
3. Attach tooling (H) to charging valve.
4. Turn tee handle (H1) in the counterclockwise direction to open screw (17). Carefully open manual purge valve (H2). Release pressure slowly until the gas pressure is discharged.
5. Close the manual purge valve (H2).

Testing and Charging Procedure for the Accumulator Precharge Pressure

Note: Test the accumulator precharge pressure when the machine is not running and all pressure has been released from the hydraulic system. Refer to the Hydraulic System Discharge section in the Operation and Maintenance Manual.

1. Before connecting tooling, close needle valve (D6). Turn the valve handle in the clockwise direction to close the valve.
2. Assemble tooling (D), tooling (H), tooling (J), and tooling (K). Refer to Figure 37.
3. Install regulator assembly (D8) on nitrogen tank valve. Adjust the screw on regulator (D8) to set the appropriate charge pressure. Refer to Figure 30 for the correct pressure reading based on temperature. Use tooling (F) to determine the correct temperature.

Note: If the machine has been running for some time, the temperature of the accumulator may be different from the ambient temperature of the outside air. Use tooling (F) to determine the current temperature of the accumulator.

4. Remove cap (16) from nitrogen charging valve. In many cases, Tooling (H) will not be able to apply enough force to break loose vent screw (17). If necessary, use an Allen wrench to break loose and retighten the vent screw. Turn the vent screw counterclockwise to loosen the screw.
6. Attach tooling (H) to the nitrogen charging valve. Hand tighten cap nut (H3).
7. Open manual purge valve (H2). Open needle valve (D6). Allow nitrogen flow to purge air from the lines through the purge valve. After the air is purged, close manual purge valve (H2). Close needle valve (D6).
8. Turn tee handle (H1) a maximum of three turns in the counterclockwise direction. The gauge on tooling (H) will show the gas precharge pressure.
8. Open the shutoff valve on the nitrogen tank. Slowly open needle valve (D6).
9. Precharge the accumulator slowly. Charging too quickly may damage the accumulator. When the desired pressure is reached, close needle valve (D6). Close the shutoff valve on the nitrogen tank.
10. Allow the temperature of the accumulator to stabilize, then recheck the pressure. When the desired pressure is reached, turn tee handle (H1) to close the nitrogen charging valve.
11. Open needle valve (D6). Slowly open manual purge valve (H2) to allow pressure in the charging equipment to purge off. When no pressure remains in the lines, close manual purge valve (H2). Remove cap nut (H3) from the accumulator. Remove regulator (D8) from the nitrogen tank.

Hydraulic Pump Testing and Adjusting

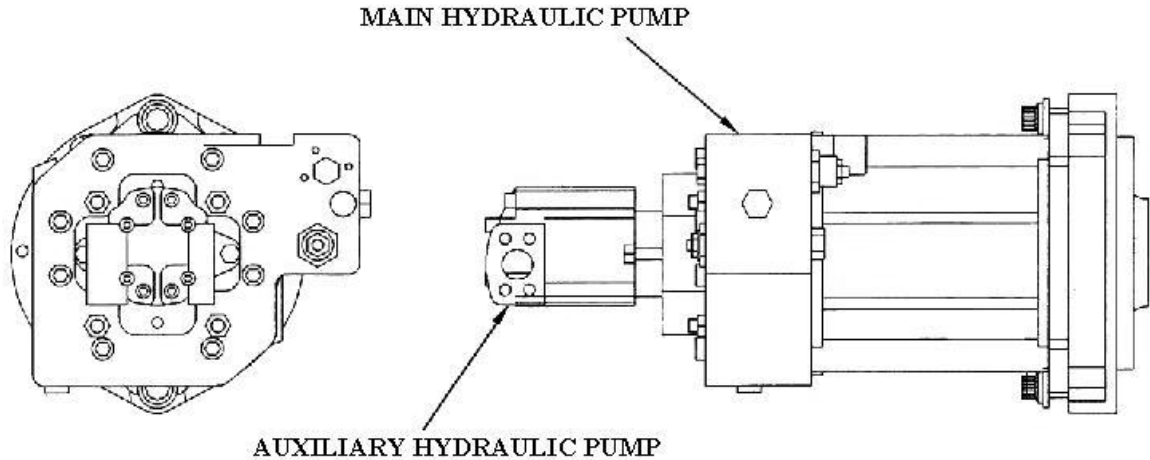

Figure 38: Hydraulic pump {1} assembly.

There are two hydraulic pumps for the hydraulic system. The main hydraulic pump is a piston pump, which supplies the drawworks. The auxiliary hydraulic pump is a gear pump, which supplies the counterweight circuit and the winch train lubrication circuit. Auxiliary hydraulic pump is not adjustable.

Follow the procedure outlined out in the Hydraulic System Implementation section before carrying out any tests or adjustments on the drawworks.

Note: Remove only the appropriate guards and covers necessary to gain access to the hydraulic component to be tested/adjusted. Replace guards/covers when access to components is no longer required, or when protection from possible component failure is required prior to activating the system.

Margin Pressure

Margin pressure is the additional pump supply pressure above the required load pressure. The pump output is always above the pressure that is required by the system, up to the maximum pressure setting. Perform the following test in order to ensure that the margin pressure is set correctly.

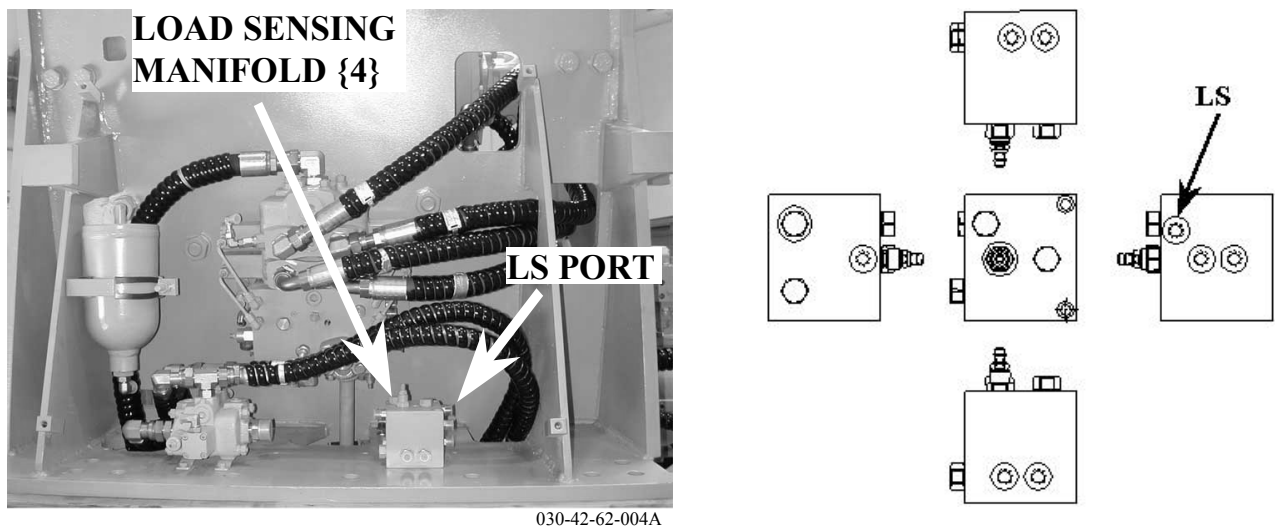

Figure 39: Load sensing manifold {4}. (LS) Load sensing port.

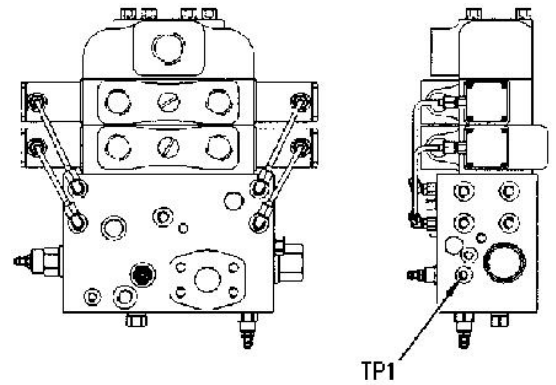
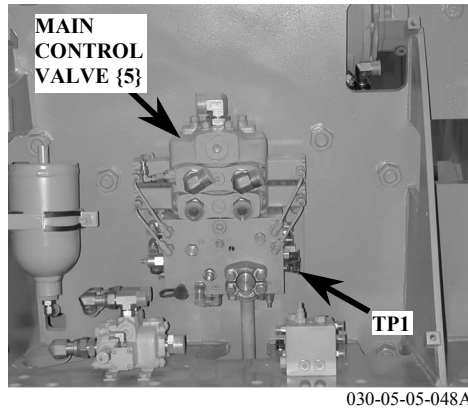
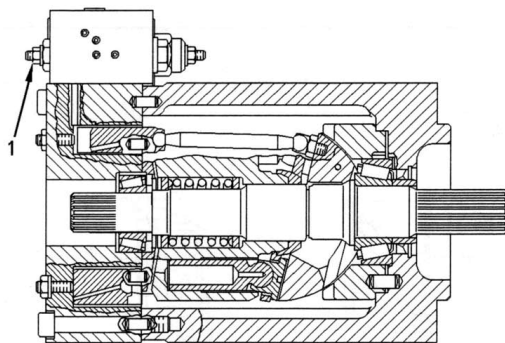
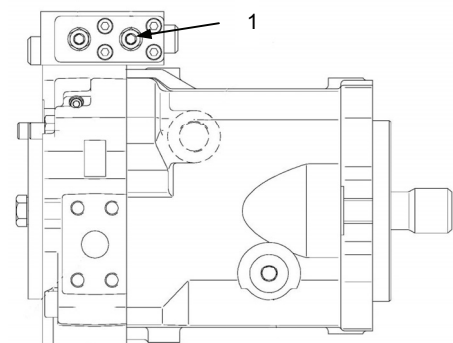

Figure 40: Location of Pump pressure port (TP1) on main control valve {5}.

1. Move the hook control lever several times to release pressure in the hydraulic system. Refer to the High Hydraulic System Pressure section.
2. Extend the counterweight and remove the access panel covering the pipelayer valves.
3. Install a pressure tap in the line connected to port (LS) on the load sensing manifold {4}. Connect the low side of a 35 000 kPa (5000 psi) differential pressure gauge to the pressure tap. If a differential gauge is not available, connect a 35 000 kPa (5000 psi) pressure gauge.
4. Connect the high side of the 35 000 kPa (5000 psi) differential pressure gauge to port (TP1) on the main control valve {5}. If a differential gauge is not available, connect a second 35 000 kPa (5000 psi) pressure gauge.
5. Start the engine and move the throttle to HIGH IDLE position. Move the hook control lever to the LOWER position. Record the value from the differential pressure gauge or the (LS) and (TP1) pressure gauges.
6. The differential pressure gauge gives a direct reading of the margin pressure. If two separate gauges are used, subtract the pressure reading (LS) from the pressure reading (TP1). This is the margin pressure. The margin pressure should be 2100 ± 700 kPa (300 ± 100 psi).



TYPE 1



TYPE 2

Figure 41: Main hydraulic pump. (1) Flow compensator spool.

7. If the margin pressure is not correct, adjust the flow compensator spool to the correct pressure. Loosen the lock nut and turn the adjustment screw (1) clockwise in order to increase the pressure. Turn the screw counterclockwise in order to decrease the pressure. The flow compensator spool is located on the main hydraulic pump, which is beneath the guard covering the hook winch manifold and the pump. Tighten the lock nut in such a way as not to alter the adjustment screw, once the correct setting has been made.

Cutoff Pressure

The cutoff pressure is the highest supply pressure that is produced by the main hydraulic pump. Once this pressure is reached, the output pressure will not rise further. Perform the following test in order to ensure that the cutoff pressure is set correctly.

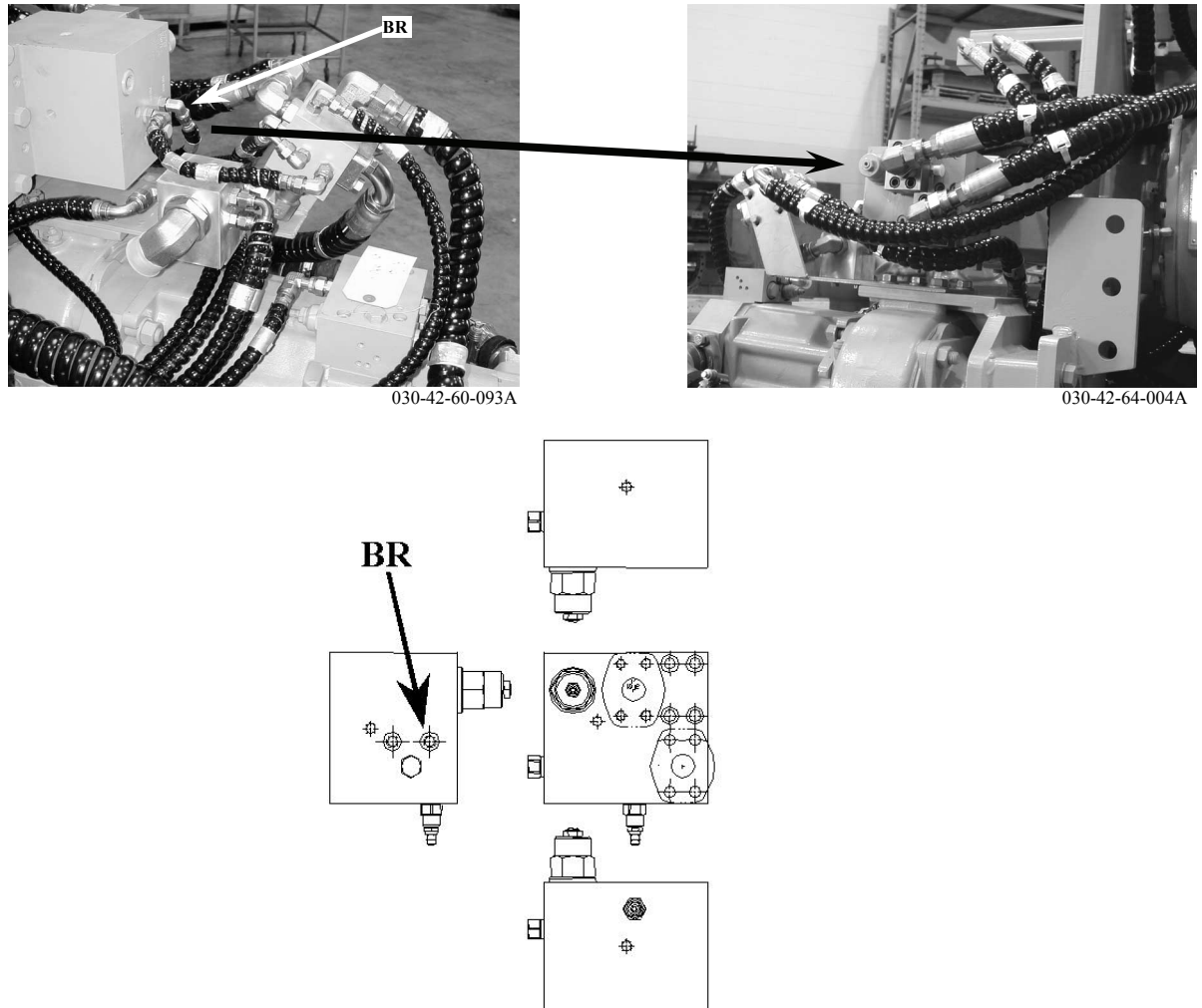

Figure 42: Hook winch manifold – (BR) Brake release port – mounted on hook winch {11}.

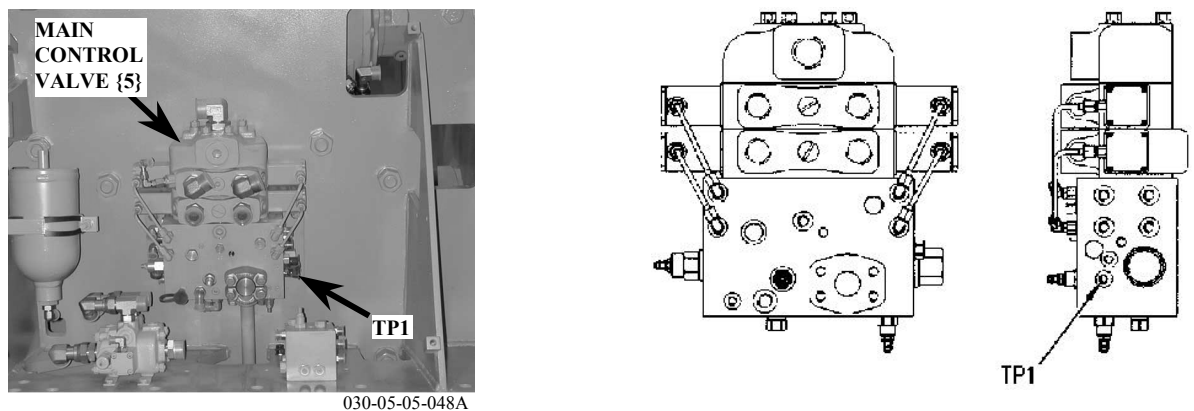

Figure 43: Location of Pump pressure port (TP1) on main control valve {5}.

1. Disconnect the brake release line from the hook winch brake manifold on the hook winch {11} motor. Plug port (BR) on the winch.

2. Connect a 40 000 kPa (6000psi) pressure gauge to port (TP1) on the main control valve.
3. Start the engine and move the throttle to the HIGH IDLE position. Slowly move the hook control lever to the LOWER position. Measure the pressure on the gauge at (TP1). This is the cutoff pressure for the pump. The pressure should be $30\ 000 \pm 700$ kPa (4300 ± 100 psi).

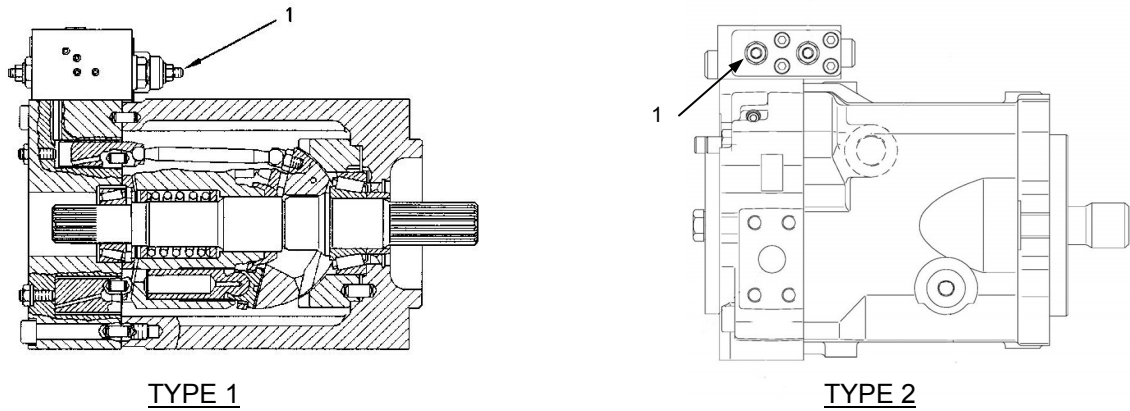

Figure 44: Main hydraulic pump. (1) Pressure compensator spool.

4. If the cutoff pressure is not correct, ensure that the main relief valve is functioning properly as outlined in the Relief Valve section.
5. If the main relief is functioning and set correctly, but the cutoff pressure is still not correct, adjust the pressure compensator spool to the correct pressure. Loosen the lock nut and turn the adjustment screw (1) counterclockwise in order to decrease the pressure. Turn the adjustment screw (1) clockwise to increase the pressure. Once the correct pressure has been achieved, tighten the lock nut, taking care not to alter the setting. The pressure compensator spool is located on the main hydraulic pump, which is beneath the guard covering the hook winch manifold and the pump {1}.



Figure 45: Pump guard.

Main Control Valve

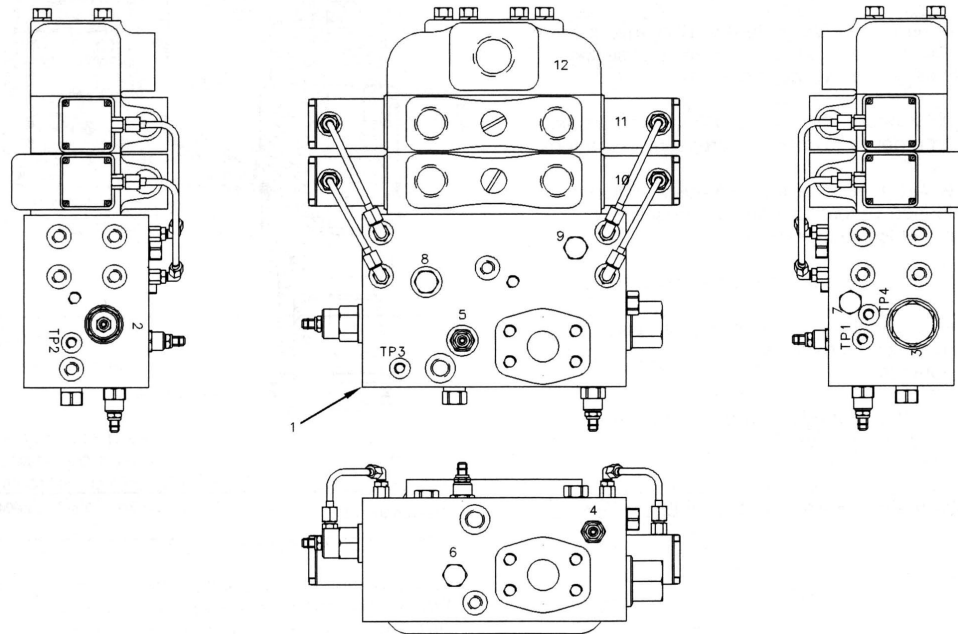

Figure 46: Main control valve {5}. (1) Manifold, (2) relief valve, (3) two-way pilot control valve, (4) -way pilot control valve, (5) pressure reducing valve, (6) check valve, (7) shuttle valve, (8) shuttle valve, (9) shuttle valve, (10) hook control valve, (11) boom control valve, (12) return manifold, (TP1) test port (pump pressure), (TP2) test port (pilot pressure), (TP3) test port (accumulator), (TP4) test port (valve opening pressure).

The main control valve {5} controls the operation of the hook {11} and boom {12} winches. The main control valve {5} is located behind access panel covering the pipelayer valves. Perform the following procedures in order to ensure that the components of the main control valve {5} are set correctly.

Note: Remove only the appropriate guards and covers necessary to gain access to the hydraulic component to be tested/adjusted. Replace guards/covers when access to components is no longer required, or when protection from possible component failure is required prior to activating the system.

Follow the instructions in the Hydraulic System Implementation section.

Main Relief Valve

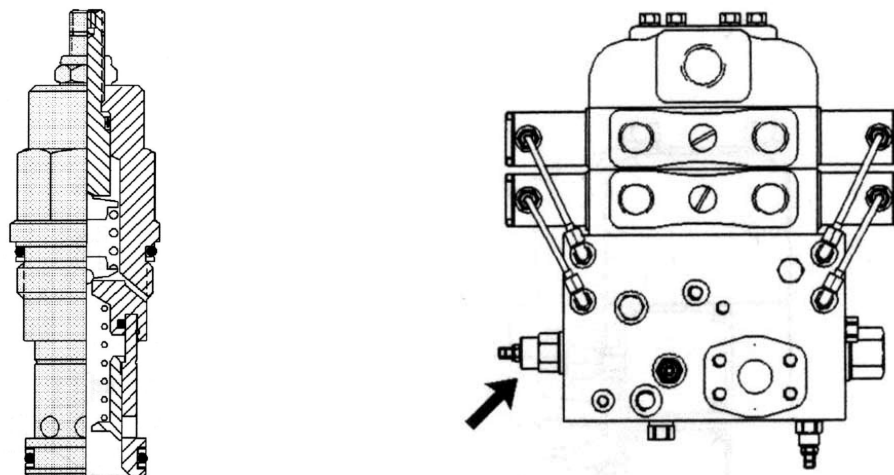

Figure 47: Location of the main relief valve.

The main relief valve controls the maximum system pressure. The relief valve protects the hydraulic components from damage caused by high-pressure spikes. It is installed in the main control valve manifold {5} located behind the access panel covering the pipelayer valves. Perform the following procedure in order to ensure that the main relief valve is set correctly.

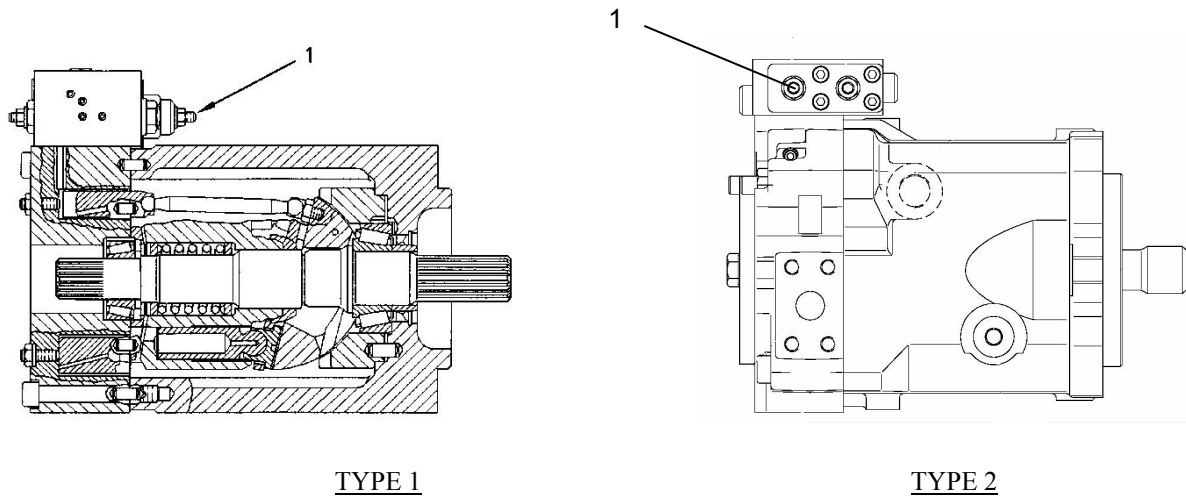
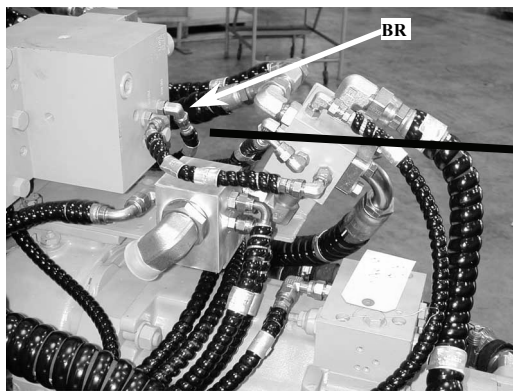

Figure 48: Main hydraulic pump.

1. Pressure compensator spool.

1. Extend the counterweights and remove the appropriate panels to gain access to the pipelayer valves and hydraulic pump.
2. Adjust the pressure compensator spool on the main hydraulic pump by two full turns clockwise in order to raise the cutoff pressure above the main relief pressure.



030-42-60-093A

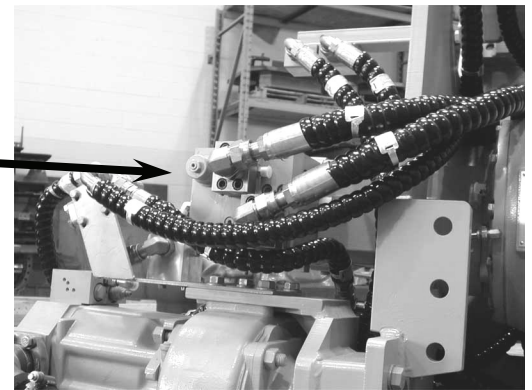

030-42-64-004A

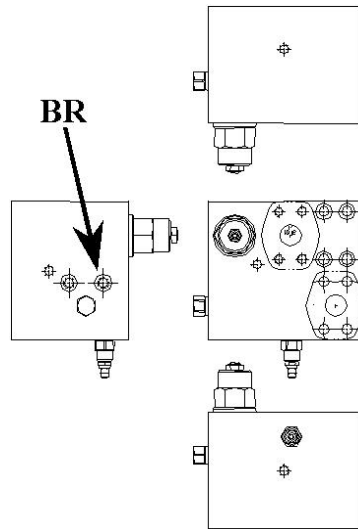

Figure 49: Hook winch brake manifold – (BR) brake release port – mounted on hook winch {11}.

3. Move the hook control lever several times, in order to release pressure in the hydraulic system. Refer to the High Hydraulic System Pressure section.
4. Disconnect the brake release line from the hook winch brake manifold on the hook winch motor at port (BR). Plug port (BR) on the winch {11}.

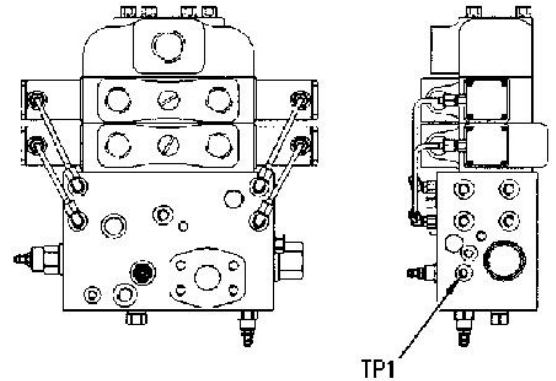
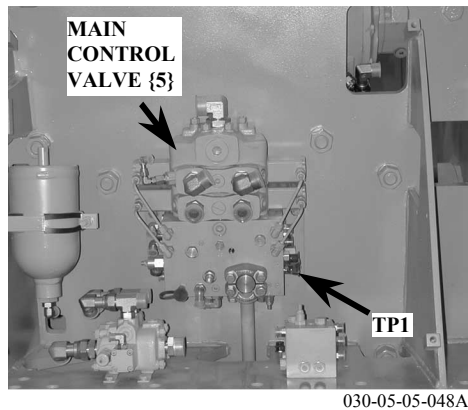

Figure 50: Location of Pump pressure port (TP1) on main control valve {5}.

5. Connect a 40 000kPa (6000psi) pressure gauge to port (TP1) on the main control valve {5}.

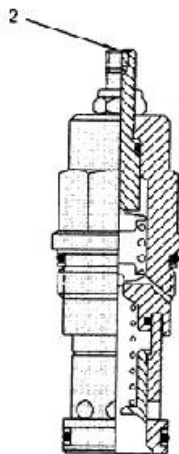

Figure 51: Main relief valve. (2) Adjustment screw.

6. Start the engine and move the throttle to the HIGH IDLE position. Slowly move the hook control lever to the LOWER position. Measure the pressure on the gauge (TP1). This is the main relief pressure setting. The pressure should be $33\,000 \pm 700$ kpa (4800 ± 100 psi).
7. If the main relief pressure is not correct, loosen the lock nut and adjust the pressure setting by turning the adjustment screw (2). Turn the screw clockwise in order to increase pressure. Turn the screw counterclockwise in order to decrease pressure. One full turn is approximately equal to 8070 kPa (1170 psi). Tighten the lock nut without altering the setting of the adjustment screw (1), once the correct pressure has been set.
8. After the main relief pressure is set correctly, adjust the pressure compensator spool to the original setting. Follow the steps outlined in the Cutoff Pressure section.

Pressure Reducing Valve (Pilot Circuit)

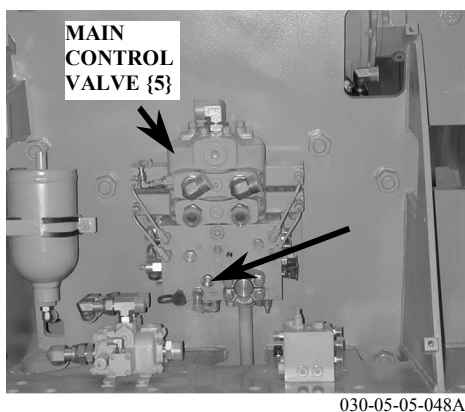

Figure 52: Location of the pressure reducing valve (Pilot Circuit).

The pressure reducing valve for the pilot circuit reduces the main pump pressure to a controllable level for the pilot control valves. The pressure reducing cartridge is installed in the main control valve manifold {5} located behind the guard covering the pipelayer valving. Perform the following procedure to ensure that the pressure reducing valve for the pilot circuit is set correctly.

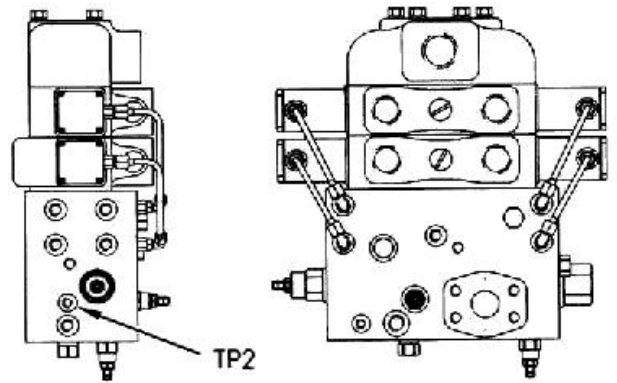
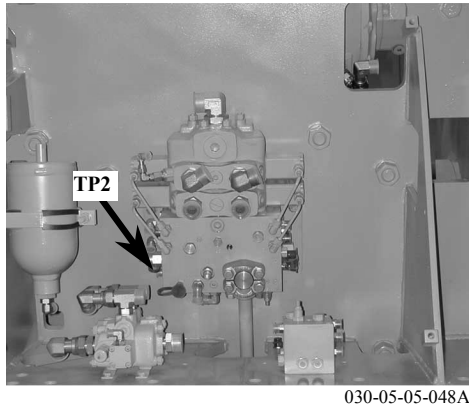

Figure 53: Location of (TP2) Pilot pressure port on main control valve.

1. Connect a 10 000 kPa (1450 psi) pressure gauge to port (TP2).
2. Start the engine. Move the throttle lever to the HIGH IDLE position.
3. Move the hook control lever to the LOWER position. Read the pressure on the gauge. The pressure should be approximately 5200 kPa (750 psi).

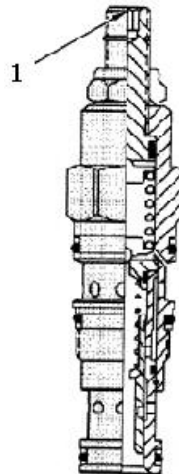

Figure 54: Pressure reducing valve (pilot circuit). (1) Adjustment screw.

4. If the pilot pressure is not correct, adjust the pressure setting by turning the adjustment screw (1). Turn the screw clockwise in order to increase pressure. One full turn is approximately equal to 6000 kPa (870 psi).

Load Sensing Manifold

The load sensing manifold {4} is used in order to resolve the highest pressure that is required by either the boom or the hook winch. This pressure signal is sent to the load sensing port on the main hydraulic pump. The pump {1} responds to supply the required pressure plus the margin pressure. The load sensing manifold {4} is located behind the access panel covering the pipelayer valving.

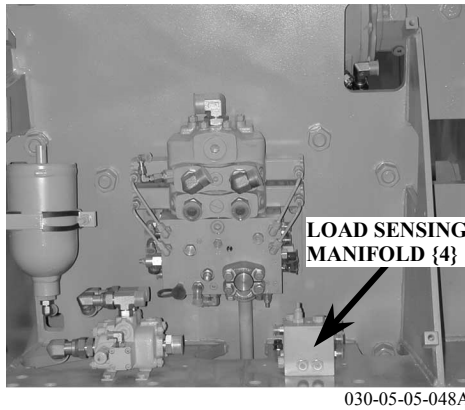

Figure 55: Location of load sensing manifold {4}.

Perform the following procedure to ensure that the load sensing manifold {4} is set correctly.

1. Follow the steps in the Hydraulic System Implementation section.

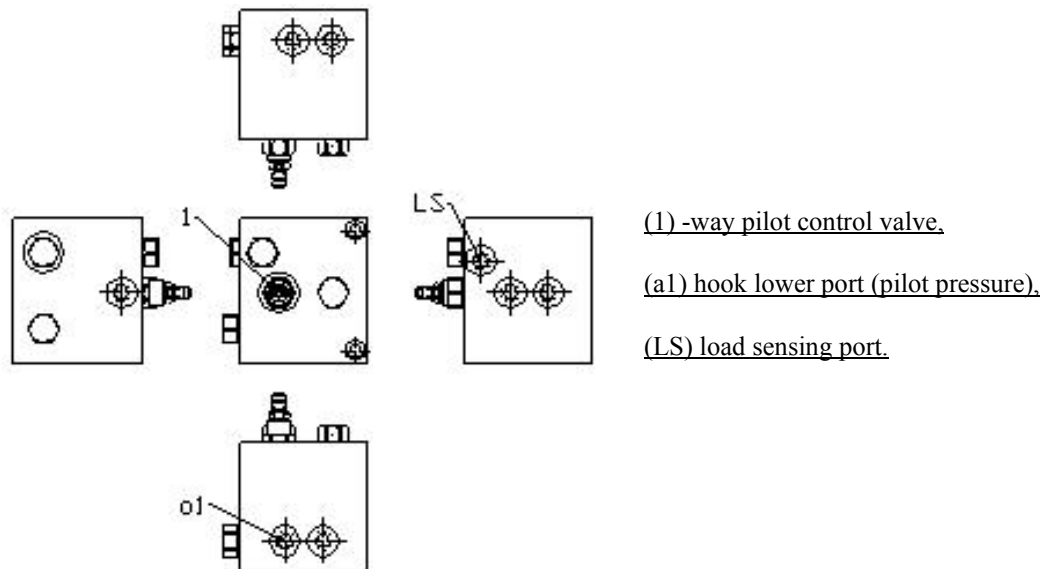

Figure 56: Load sensing manifold {4}.

2. Using a tee fitting, connect a 965 kPa (140 psi) pressure gauge to the hook lower pilot line (a1) at the load sensing manifold {4}.
3. Using a tee fitting, install a 9650 kPa (1400 psi) in the load sensing line (LS) that connects the load sensing manifold {4} to the hydraulic pump via the (LS) port.
4. Start the engine. Move the throttle to the HIGH IDLE position.
5. Slowly move the hook control lever a small distance toward the LOWER position, and check the pressure in the load sensing line (LS). When the gauge in the load sensing line begins to register a pressure, record the pressure in the hook lower pilot line (a1). The pressure at (a1) should be approximately 620 kPa (90 psi).



Figure 57: 2-way pilot control valve.

- If the pressure is not correct, adjust 2-way pilot control valve by turning the adjustment screw (2). Turn the screw clockwise in order to increase pressure. Turn the screw counterclockwise in order to decrease pressure. One full turn is approximately equal to 520 kPa (75 psi).

Hook Winch Brake Manifold

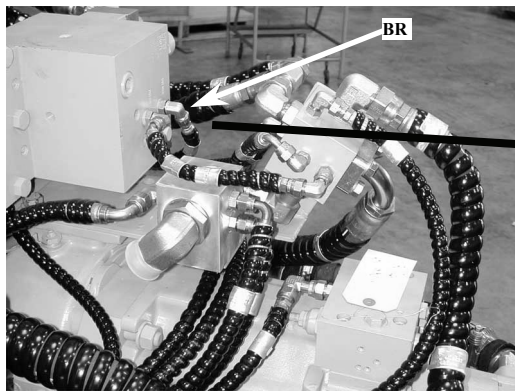

030-42-60-093A

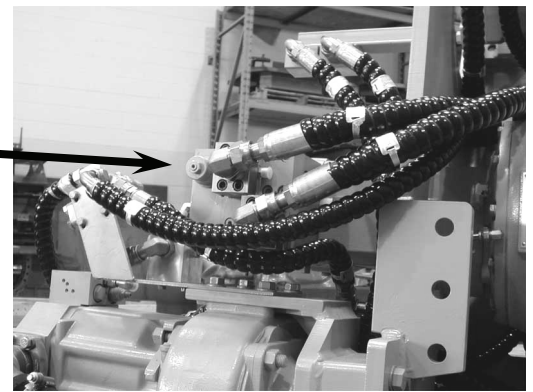

030-42-64-004A

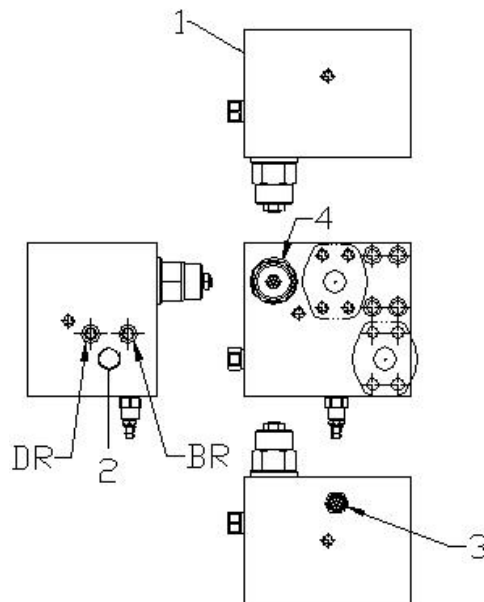

- (1) Manifold
- (2) directional valve
- (3) pressure reducing valve
- (4) counterbalance valve

Figure 58: Hook winch brake manifold, mounted on hook winch {11}.

The hook winch brake manifold is mounted on the hook winch motor. This valve performs two functions. First, the pressure reducing valve (3) sets the pressure to the brake release port on the hook winch. Second, the counterbalance valve (4) controls the back pressure in the winch motor when the hook is lowered. Perform the following procedures to ensure that the components of the hook winch brake manifold are set correctly.

Hook Brake Release Pressure Testing and Adjusting

1. Follow the procedures in the Hydraulic System Implementation section.
2. Using a tee fitting, connect a 16 000 kPa (2300 psi) pressure gauge to port (BR) on the hook winch brake manifold.
3. Start the engine. Move the throttle control lever to the HIGH IDLE position.
4. Move the Speed/Lockout Control Lever to HIGH SPEED MODE—WINCH CONTROLS UNLOCKED (Hare).
5. Move the hook control lever fully to the LOWER position. Record the pressure on the gauge. This is the hook brake release pressure. The pressure should be approximately 8600 kPa (1250 psi).

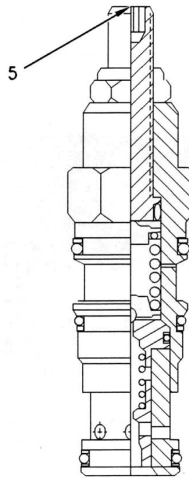

Figure 59: Pressure reducing valve. (5) Adjustment screw.

6. If the pressure is not correct, adjust the pressure by turning the adjustment screw (5). Turn the screw clockwise in order to increase pressure. Turn the screw counterclockwise to decrease the pressure. One full turn is approximately equal to 6000 kPa (870 psi).

Hook Winch Counterbalance Valve

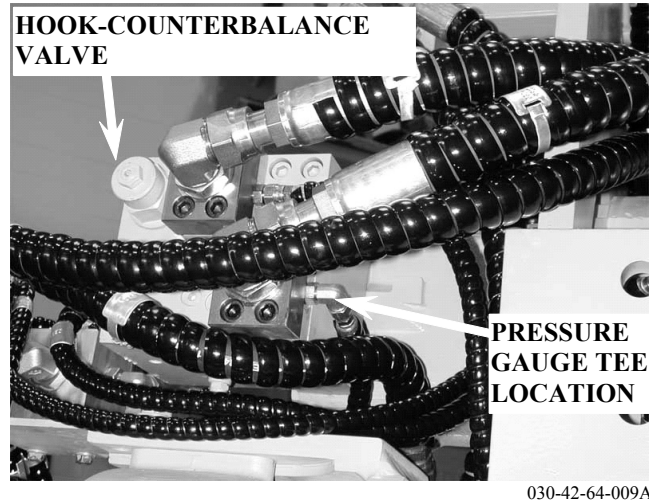

Figure 60: Location of pressure gauge tee, on hook winch brake manifold.

1. Follow the procedures in the Hydraulic System Implementation section.
2. Install a tee fitting at the location shown in Figure 60 and reconnect the hose line.
3. Connect a 60 000 kPa (8700 psi) pressure gauge to the tee fitting.
4. Start the engine. Move the throttle control lever to the HIGH IDLE position.
5. Move the Speed/Lockout Control Lever to HIGH SPEED MODE—WINCH CONTROLS UNLOCKED (Hare).
6. Move the hook control lever fully to the LOWER position. Record the pressure on the gauge.
7. The result should be approximately 22 800 kPa (3300 psi).

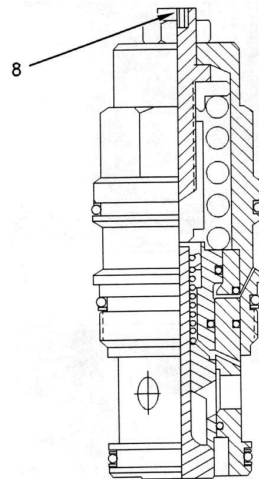
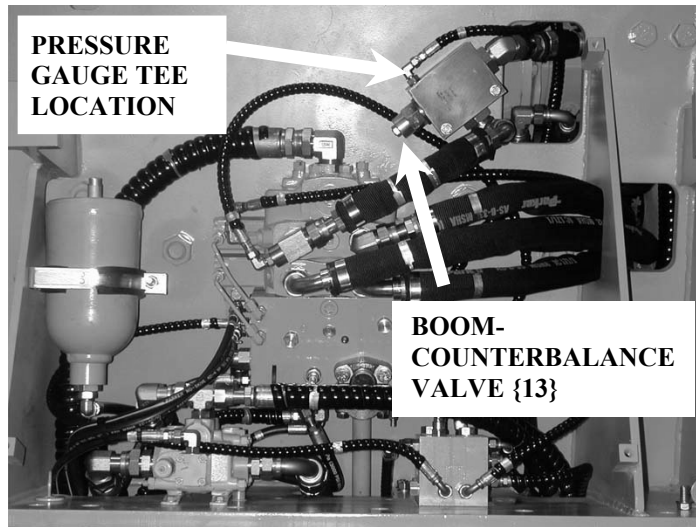

Figure 61: Counterbalance valve. (8) Adjustment screw.

8. If the counterbalance valve pressure is not set correctly, adjust the valve by turning adjustment screw (8). Turn the screw **counterclockwise** to increase pressure. Turn the screw **clockwise** to decrease the pressure. One full turn is approximately equal to 6900 kPa (1000 psi).

Boom-Counterbalance Valve



029-42-65-026A

Figure 62: Location of pressure gauge tee on main control valve.

1. Follow the procedures in the Hydraulic System Implementation section.
2. Install a tee fitting at the location shown in Figure 62 and reconnect the hose line.
3. Connect a 60 000 kPa (8700 psi) pressure gauge to the tee fitting.
4. Start the engine. Move the throttle control lever to the HIGH IDLE position.
5. Move the Speed/Lockout Control Lever to HIGH SPEED MODE—WINCH CONTROLS UNLOCKED (Hare)
6. Move the boom control lever to the LOWER position. Record the pressure on the gauge.
7. The result should be approximately 14 480 kPa (2100 psi).

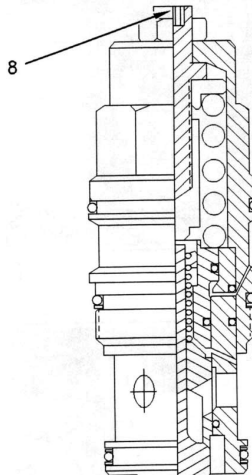

Figure 63: Counterbalance valve. (8) Adjustment screw.

8. If the counterbalance valve pressure is not set correctly, adjust the valve by turning adjustment screw (8). Turn the screw **counterclockwise** to increase pressure. Turn the screw **clockwise** to decrease the pressure. One full turn is approximately equal to 6900 kPa (1000 psi).

Boom stop Valve Adjustment

Refer to the Boom stop Valve Adjustment procedure in the Maintenance and Lubrication section.

Boom stop PX-Valve Adjustment

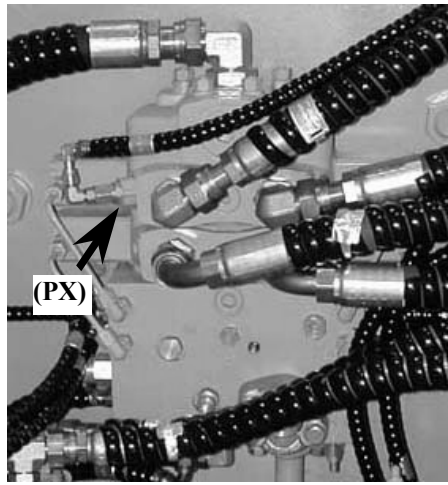

030-42-62-005B

Figure 64: Boom stop PX-valve (PX) on main control valve {5}.

If the boom winch {12} pauses before hauling-in, or does not haul in, bleed the pilot line at the PX-valve (PX) on the main control valve {5}.

Counterweight Relief Valve Testing and Adjusting

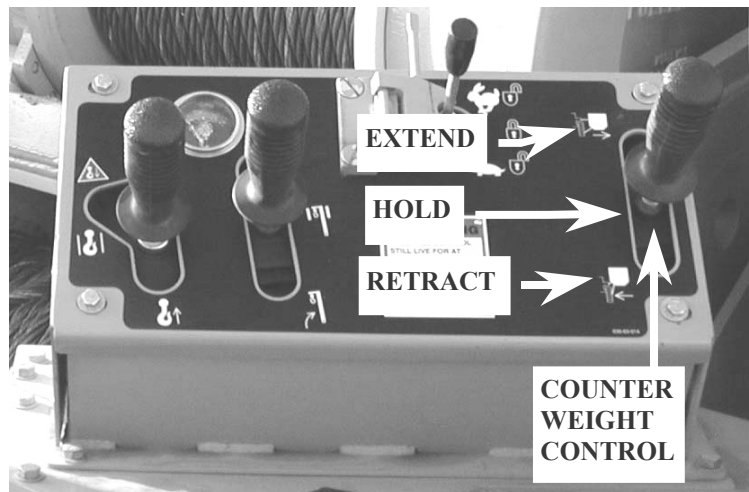

030-05-63-006B

Figure 65: Counterweight control lever.

1. Follow the procedures outlined in the Hydraulic System Implementation section.
2. Extend the counterweight.
3. Stop the engine.
4. Move the hook control lever several times, in order to release the pressure in the counterweight hydraulic circuit. Refer to the High Hydraulic Pressure section.

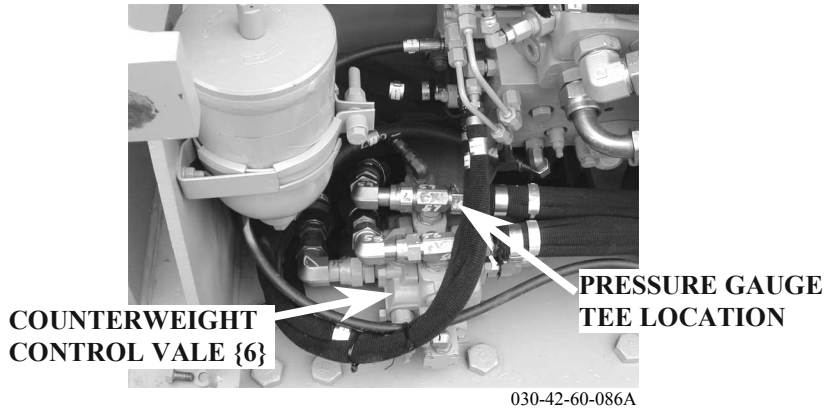

Figure 66: Location of counterweight pressure gauge tee.

5. Using an additional tee fitting, attach a 40 000 kPa (5800 psi) pressure gauge in the line at the tee shown in Figure 66.
6. Start the engine again and move the counterweight control lever to the EXTEND position, and fully extend the cylinders. With the cylinders fully extended, move the counterweight control lever slightly toward the EXTEND position. Record the pressure indicated on the gauge. This is the counterweight relief valve pressure setting. The pressure should be approximately 12 400 kPa (1800 psi).

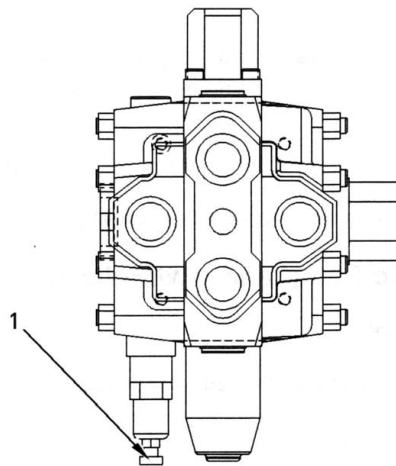

Figure 67: Counterweight control valve {6}. (1) Relief valve adjustment screw.

7. If the pressure is not correct, adjust the pressure by turning the relief valve adjustment screw (1) on the counterweight relief valve {6}. Turn the screw clockwise in order to increase pressure. Turn the screw counterclockwise in order to decrease pressure.

Troubleshooting

Problem Checklist

1. The temperature of the oil is too hot.
2. The pump {1} makes unusual noises.
 - a. The implements do not move slowly.
 - b. Air bubbles in the oil.
3. A large amount of air in the oil.
4. Low pressure standby is too low.
5. Low pressure standby is too high.
6. Margin pressure is too low.
7. Margin pressure is too high
8. The pump discharge pressure is too high - high pressure stall.
9. The pump discharge pressure is too low - high pressure stall.
10. There is a pause before pressure is reached in all circuits.
11. Signal pressure and/or tank pressure is not at zero when all of the valves are in the Hold position.
12. The hook or the boom will not power down.
13. The hook or the boom will not reel in.
14. The boom winch {12} pauses before hauling-in, or will not haul-in.

No. 1. Problem

The temperature of the oil is too hot

Probable cause:

1. The viscosity of the oil is wrong. Refer to the Lubricant Specifications section.
2. The pump {1} is too worn.
3. There is a restriction in an oil passage.
4. The load on the system is too high.
5. Oil aeration (leak on the inlet side of the pump).
6. Low oil level in the hydraulic tank {2}.
7. The flow compensator valve is set incorrectly - margin pressure is too high.
8. The outside air temperature is too hot.

No. 2. Problem

The pump {1} makes unusual noises.

- a. **The implements do not move slowly.**
- b. **Air bubbles in the oil.**

Probable cause:

1. The viscosity of the oil is wrong. Refer to the Lubricant Specifications section.
2. There is a loose connection of the oil line on the inlet side of the pump {1}. Oil aeration.
3. There is a restriction in the inlet line of a pump {1}.
4. The pump {1} is too worn.
5. Low oil level in the hydraulic tank {2}.

No. 3. Problem

A large amount of air in the oil

Probable cause:

1. A leak in the oil line between the tank {2} and the pump {1}.
2. Low oil level in the hydraulic tank {2}.
3. Leakage around the counterweight cylinder seals.

No. 4. Problem

Low pressure standby is too low.

Probable cause:

1. The flow compensator valve is set incorrectly.
2. The spring in the flow compensator valve is broken.
3. The pump {1} is not upstroking. The swashplate is blocked or the actuator spring is broken.
4. A low setting of the pressure compensator valve or a broken spring.

No. 5. Problem

Low pressure standby is too high.

Probable cause:

1. The flow compensator valve is set incorrectly.
2. Signal pressure from the implements has not bled off.

No. 6. Problem

Margin pressure is too low.

Probable cause:

1. The flow compensator valve is set incorrectly.
2. Leak in the signal network in the load sense manifold {4}.

No. 7. Problem

Margin pressure is too high.

Probable cause:

1. The flow compensator valve is set incorrectly.

No. 8. Problem

The pump discharge pressure is too high - high pressure stall.

Probable cause:

1. The pressure compensator valve is set incorrectly.
2. The pressure compensator valve is stuck.
3. The pump {1} is not destroking. The swashplate is blocked or the actuator piston is stuck.

No. 9. Problem

The pump discharge pressure is too low - high pressure stall

Probable cause:

1. The pressure compensator valve is set incorrectly.
2. Spring in the pressure compensating valve is broken or fatigued.
3. Line relief valves are set too low.
4. The load sensing manifold {4} is leaking.

No. 10. Problem

There is a pause before pressure is reached in all circuits.

Probable cause:

1. Air in the signal network in the main control valve.
2. Dirt or debris in the oil could cause a shuttle valve to be held open momentarily.
3. The -way control valve in the load sensing manifold {4} is set incorrectly.

No. 11. Problem

Signal pressure and/or tank pressure is not at zero when all of the valves are in the HOLD position.

Probable cause:

1. All controls are not in HOLD.
2. The load sensing manifold {4} is not vented.

No. 12. Problem

The hook or boom will not power down.

Probable cause:

1. The brake is not releasing. Perform the brake pressure test.
 - a. The seals on the brake piston are bad.
 - b. Leakage in the control valve.
2. One or both counterbalance valves are not set correctly. Perform the pressure test on the counterbalance valves (hook-winch {11}, boom-counterbalance valve {13}).
3. The winch motor is bad.
4. The sprag clutch is bad.
5. Mechanical failure in the winch.

No. 13. Problem

The hook or boom will not reel in.

Probable cause:

1. The winch motor is bad.
2. Mechanical failure in the winch.
3. The sprag clutch is bad.

No. 14. Problem

The boom winch {12} pauses before hauling-in, or will not haul-in.

Probable cause:

1. Air trapped in line from boom stop valve {8} to PX-valve on main control valve {5}. Bleed the line at the PX-valve.

Appendix A: PULLMASTER Winch Corporation – Winch Rigging Anchor procedures

To install cable anchor sub-assembly 23456 in the drawworks hook winch {11} part # 78166 (model M30D-8-173-48D-498), follow the steps listed below (Ref: Pullmaster Drawing SI1047 – Rev A):

Step 1: Feed the 19.05 mm (3/4 in) wire rope through the cable anchor slot as shown below.

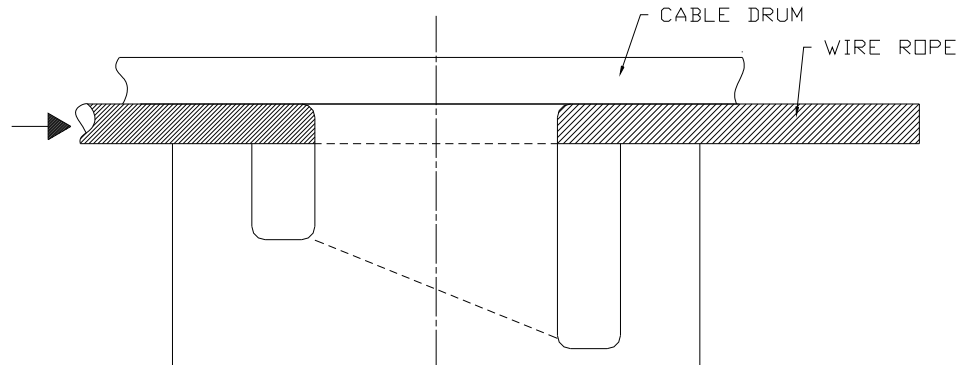

Step 2: Make certain 2 to 4 threads of the capscREW (23459) are engaged in cable anchor (23436). Insert cable anchor assembly (23456), starting with socket head capscREW, in the cable anchor slot as far as it will go and the threaded hole in the cable anchor nearest the wire rope. Rotate the retainer (23457) so that lip of the retainer faces the top edge of the cable anchor slot.

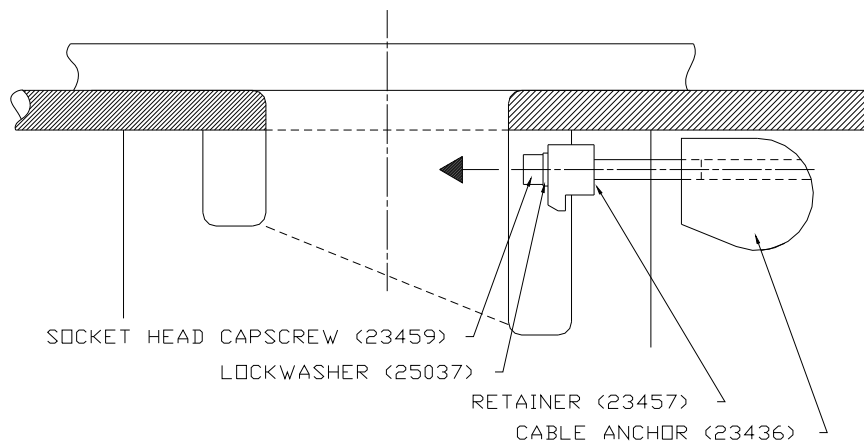

Step 3: Push and hold the head of the socket head capscrew, so that the lip of the retainer (23457) rests against the edge of the cable anchor slot. Loop the wire rope and feed the end into the slot past the cable anchor. The end of the wire rope should be approximately 6.35 mm ($\frac{1}{4}$ in) to 19.05 mm ($\frac{3}{4}$ in) inside the lip of the cable anchor slot.

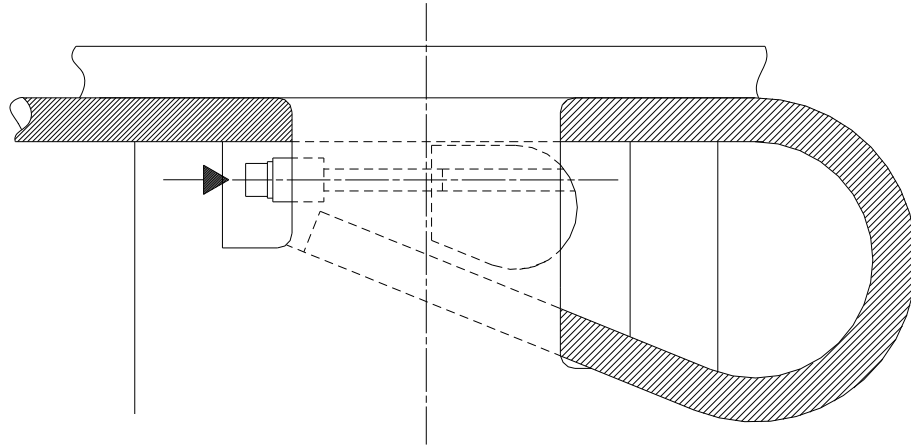

Step 4: Pull the wire rope until the wire rope is seated against the cable anchor. Tighten the capscrew with 41 to 47 Nm (30 to 35 lb-ft) torque.

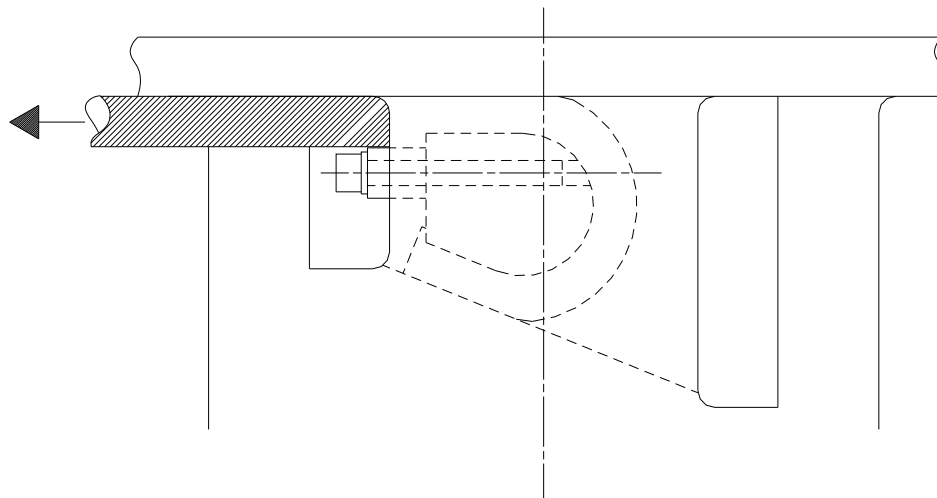

Appendix B: PULLMASTER WINCHES

Boom Winch Service Instructions – M30D-9-174-49-536



**FAILURE TO FOLLOW INSTALLATION INSTRUCTIONS WILL
RESULT IN PROPERTY DAMAGE, SEVERE INJURY OR DEATH.**

The initial installation or mounting of a PULLMASTER WINCH is critically important for proper operation and performance. The model M30D # 78193 winch is mounted to a machined common base. It is very important that the following instructions are observed when installing the PULLMASTER WINCH:

- 1) Make certain that the mounting platform is sufficiently strong to avoid deflection when a load is lifted.
- 2) If the winch has been removed from the common base for servicing, the correct bolts and washers must be used when reinstalling the winch. Tighten all twenty-six (26) capscrews per bolt torque chart.
- 3) Fill the winch with lubricating oil (see specifications).
- 4) Use recommended circuit components and hydraulic hoses.
- 5) The circulation return line of the winch should be plumbed in such a manner that the brake housing remains full of oil at all times. Connect the circulation return line directly to reservoir. Do not connect to a common return line.
- 6) Before operating the winch with a load, verify adequate circulation flow through the circulation return line as stated in TYPICAL HYDRAULIC CIRCUIT. Verify that pressure measured at the circulation supply port does not exceed the permissible pressure stated in SPECIFICATIONS. Winches equipped with the internal circulation option will supply circulation flow only when the winch is run in the lowering direction.

SERVICE INSTRUCTIONS

GENERAL:

Before attempting disassembly of the PULLMASTER Model M30 Planetary Winch, the following instructions for disassembly and reassembly should be read and understood:

It is suggested that all expendable parts, such as O-rings and oil seals, are not reused on reassembly. It is therefore important to have a seal kit (Part No. 23804).

NOTE: Backup washers may be included with seal kit. Install with oil seals as per instructions. If not present in seal kit, the oil seals supplied do not require backup washers.

A clean working area is of prime importance, similar to conditions used for service work on any other hydraulic component. All parts, as they are removed from the winch assembly, should be inspected for wear and damage. Worn or damaged parts must be replaced. Thoroughly clean parts before reassembly. Do not use solvent to clean the brake friction plates.

During reassembly, lubricate all O-rings and oil seals with grease before installation.

In the following service instructions, reference to parts is made by numbers and shown on the applicable group drawings.

DISASSEMBLY

For the majority of required service or repair work, disassembly is required only on the brake housing of the PULLMASTER Model M30 planetary winch. There are no special tools needed for the service or repair work and no adjustments or calibrations are necessary. Proceed with the disassembly as follows:

REMOVAL OF HYDRAULIC MOTOR:

If the analyzed service or repair work requires access to the interior of the brake housing, the hydraulic motor should not be removed. In this case, the hydraulic motor should be removed together with the motor adaptor as a complete assembly. If a problem has been analyzed to be in the hydraulic motor, proceed as follows:

- 1) Disconnect motor hydraulic supply, drain and brake release hoses.
- 2) Remove two capscrews, item 551, together with washers, item 553 which attach motor, item 950.
- 3) Support and carefully withdraw motor from adaptor, item 800, and motor drive shaft, item 730.
- 4) Remove and discard O-ring, item 819

REMOVAL OF HYDRAULIC MOTOR ASSEMBLY:

If removal of the hydraulic motor is not necessary, proceed as follows:

- 1) Remove 12 hex head capscrews, item 537, with lockwashers, item 541, from motor adaptor, item 800. (Since the brake springs, item 752, apply pressure against the inside of the motor adaptor, it is recommended that the hex capscrews are unscrewed, one turn at a time, until the spring pressure has been released). The complete motor assembly, including motor adaptor, can now be removed from brake housing assembly.
- 2) Remove and discard O-rings, item 801, and O-ring, item 707. (O-rings, item 801, seal the pressure transfer hole for the automatic brake release and are situated on the flange of the brake housing).

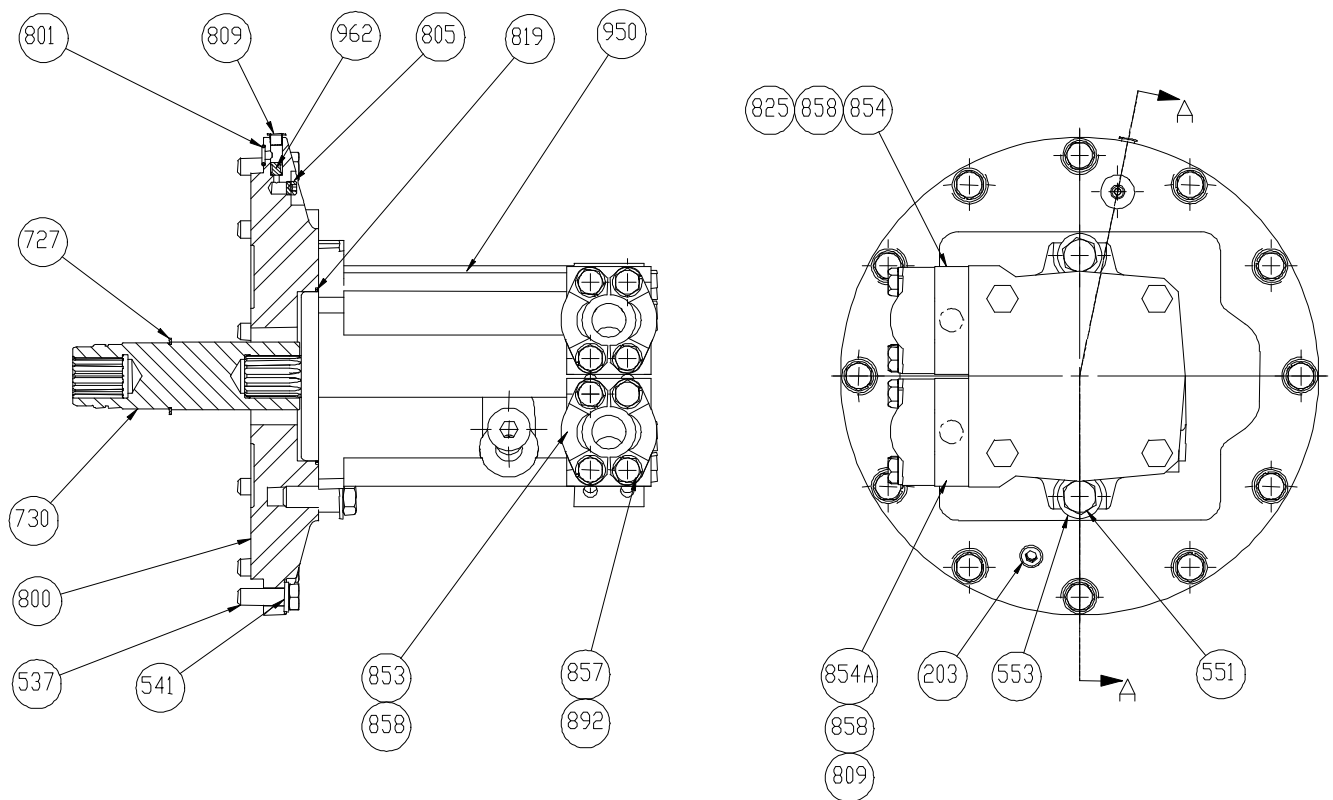

DISASSEMBLY OF BRAKE HOUSING ASSEMBLY:

- 1) After motor assembly has been removed, all parts of brake assembly are accessible. Remove 14 brake springs, item 752. Thoroughly examine springs for damage and measure overall length. Overall spring length should be 2.27 inch. If any spring measures less than 2.21 inch, replace all springs as a set.
- 2) Pull motor drive shaft, item 730, and complete brake hub assembly from brake housing.
- 3) Disassemble brake hub assembly by removing circlip, item 727, from motor drive shaft. Remove motor drive shaft from brake hub, item 720. Remove sprag clutch aligners, items 722 and 724, and sprag clutch, item 723, from brake hub.



MINOR SURFACE DEFECTS WHERE THE SPRAG CLUTCH ENGAGES THE MOTOR DRIVE SHAFT AND BRAKE HUB, WILL RESULT IN BRAKE FAILURE AND ALLOW THE LOAD TO DROP, CAUSING PROPERTY DAMAGE, SEVERE INJURY OR DEATH. THOROUGHLY INSPECT THESE AREAS AND, IF NECESSARY, REPLACE MOTOR DRIVE SHAFT, SPRAG CLUTCH AND BRAKE HUB AS A SET.

- 4) Thoroughly inspect motor drive shaft, item 730, and brake hub, item 720, particularly the surfaces where sprag clutch, item 723, engages. If any indentation or surface damage is detected, replace brake hub, sprag clutch and motor drive shaft as a set.
- 5) Pull brake piston, item 750, out of brake housing using two 5/8-11NC bolts screwed into two puller holes in piston and discard O-rings, item 751 and item 753.
- 6) Thoroughly examine inner bores of brake housing and outer diameters of brake piston for scoring caused by hydraulic fluid contamination. Minor surface damage may be repaired by polishing with a fine emery cloth.

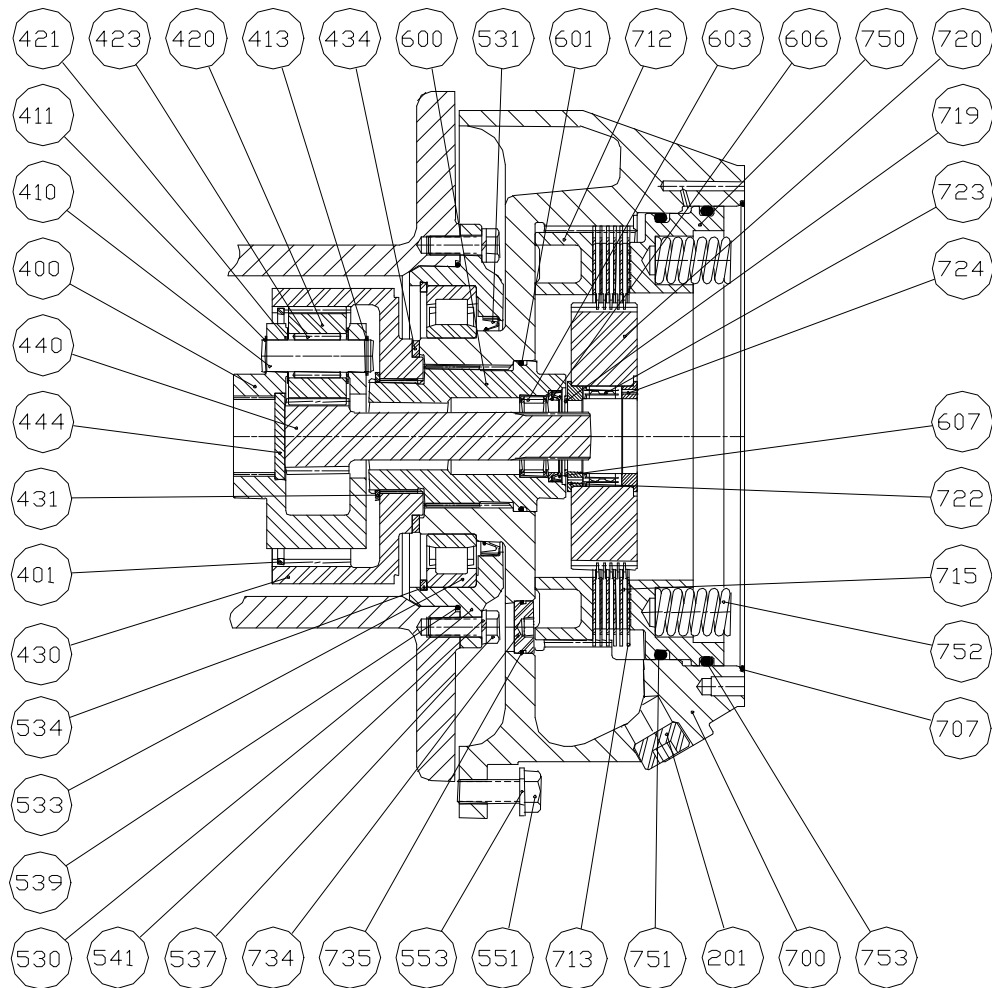

 DANGER

DAMAGED FRICTION OR DIVIDER PLATES WILL REDUCE BRAKING CAPACITY AND ALLOW THE LOAD TO DROP, CAUSING PROPERTY DAMAGE, SEVERE INJURY OR DEATH. SOLVENT MAY DAMAGE THE FRICTION PLATES. DO NOT USE SOLVENT TO CLEAN THE FRICTION PLATES. PERFORM THOROUGH INSPECTION AND, IF NECESSARY, REPLACE FRICTION AND DIVIDER PLATES AS A SET.

- 7) Remove five friction plates, item 715, together with six divider plates, item 713, and inspect for damage or wear. Plates should be flat and smooth. Plates should not show heat discoloration. Paper material on friction plates should be intact and grooved. If any damage is detected, replace friction and divider plates as a set.
- 8) Remove brake spacer, item 712.

DISASSEMBLY OF FINAL DRIVE

- 1) Remove 26 capscrews, item 551 and washers, item 553 and remove winch from common base.
- 2) Remove eight hex capscrews, item 127, and lockwashers, item 129. Remove end cover, item 120.
- 3) Discard O-ring, item 123, and inspect planet hub stopper, item 126, and sun gear stopper, item 122, for excessive wear. Replace planet hub stopper if less than .30 inch and sun gear stopper if less than .21 inch thick.
- 4) Remove final planet hub assembly from final housing, item 100.

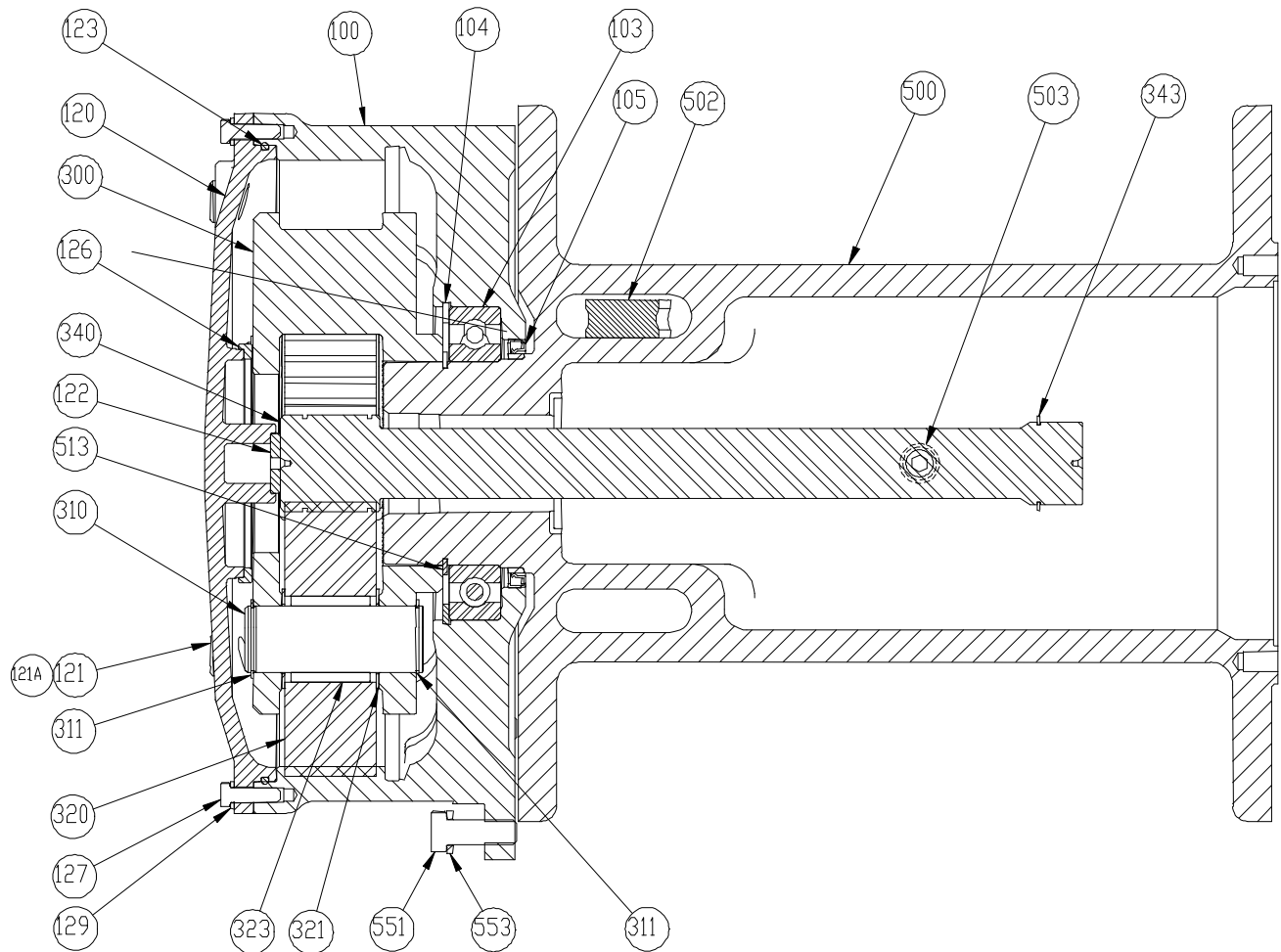

- 5) Inspect final planet gears, item 320, for damage or wear. If it is necessary to remove final planet gears, remove circlip, item 311, and press planet pin, item 310, out of planet hub, item 300. Inspect loose rollers, item 323, and two thrust washers, item 321, and replace if damaged.
- 6) Remove final sun gear, item 340, from cable drum.

DISASSEMBLY OF PRIMARY DRIVE AND CABLE DRUM ASSEMBLY

For ease of working on remainder of unit, set winch upright on final drive housing.

- 1) Remove access plug, item 734, using a ½-13NC bolt (motor adaptor bolt, item 821, works nicely), from inside brake housing and discard O-ring, item 735.
- 2) Remove six hex capscrews, item 537, with lockwashers, item 541, from bearing flange, item 530, by rotating brake housing until access hole is over top.
- 3) Lift brake housing together with bearing flange and primary planet hub assembly, out of cable drum, item 500, and discard O-ring, item 539.
- 4) Remove retaining ring, item 401, and remove primary planet hub assembly from inside internal gear, item 430.
- 5) Inspect primary planet gears, item 420, for damage or wear. If necessary to remove primary planet gears, remove circlip, item 411, and press planet pin, item 410, out of planet hub, item 400. Inspect loose rollers, item 423, and two thrust washers, item 421, and replace if damaged.

- 6) Remove primary sungear, item 440, from center of connecting shaft, item 600.
- 7) Remove circlip, item 431, and internal gear, item 430, from connecting shaft spline.
- 8) Remove spacer, item 434.
- 9) Pull connecting shaft, item 600, out of brake housing. Discard O-ring, item 601.
- 10) Remove and discard oil seal, item 607, from inside of connecting shaft.
- 11) Remove needle bearing, item 603. Inspect and replace if damaged.
- 12) Separate bearing flange, item 530, and brake housing, item 700, using a standard bearing puller or insert two heel bars in slot between bearing flange and brake housing. Pry brake housing out of cylindrical bearing, item 533.
- 13) Remove internal retaining ring, item 534, and remove the outer race and caged roller assembly of cylindrical roller bearing, item 533.
- 14) Remove and discard oil seal, item 531.
- 15) Remove the separate inner race of cylindrical roller bearing, item 533, from brake housing, item 700.

REASSEMBLY

Thoroughly clean all parts. Use only new, well-greased O-rings and oil seals. Unless otherwise specified, torque fasteners per BOLT TORQUE CHART in Appendix F.

REASSEMBLY OF FINAL DRIVE:

Reassemble final drive end of winch as follows:

- 1) Press new, well-greased oil seal, item 105, into final housing, item 100.
- 2) Press ball bearing, item 103, into final housing and secure with retaining ring, item 104.
- 3) Press cable drum, item 500, into ball bearing, item 103, and secure with circlip, item 513.
- 4) Reassemble final planet hub assembly. Use grease to temporarily hold 24 loose rollers, item 323, in bore of planet gear, item 320. Position thrust washers, item 321, on either side of planet gear and press planet pin, item 310, into final hub, item 300. Retain with circlip, item 311.
- 5) Insert final planet hub assembly into final housing, item 100. Ensure that final planet hub spline is fully engaged with cable drum, item 500.
- 6) Install new, well-greased O-ring, item 123, into end cover, item 120. Verify that planet hub stopper, item 126, and sungear stopper, item 122, are installed into end cover.
- 7) Gently insert end cover into final housing, item 100, and fasten with eight capscrews, item 127 and lockwashers, item 129.

REASSEMBLY OF PRIMARY DRIVE:

Turn winch over, resting on end cover with cable drum opening facing up. Reassemble primary drive as follows:

NOTE: Care must be taken when handling the assembly at this stage, avoid separation of the bearing flange sub-assembly and brake housing.

- 1) Press new, well greased oil seal, item 531, into bearing flange, item 530. Press outer race complete with caged, roller assembly of cylindrical roller bearing, item 533, into bearing flange and secure with retaining ring, item 534.
- 2) Install bearing flange assembly onto brake housing and then press the inner race of cylindrical roller bearing, item 533 onto brake housing, item 700, and install new, well-greased O-ring, item 539.

- 3) Press needle bearing, item 603, into connecting shaft, item 600.
- 4) Install new, well-greased oil seal, item 607, into connecting shaft.
- 5) Install new, well-greased O-ring, item 601, onto connecting shaft, item 600, and insert connecting shaft into brake housing, item 700.
- 6) Slide internal gear, item 430, along with spacer, item 434, onto end of connecting shaft and fasten in place with circlip, item 431.
- 7) Reassemble primary planet hub assembly. Use grease to temporarily hold 15 loose rollers, item 423, in bore of planet gear, item 420. Verify placement of sungear stopper, item 444. Position thrust washers, item 421, on either side of planet gear and press planet pin, item 410, into primary planet hub, item 400. Retain with circlip, item 411.
- 8) Insert primary sungear, item 440, between planet gears and insert sungear shaft into connecting shaft, engaging planet gears with internal gear. Fasten with retaining ring, item 401.
- 9) Insert final sungear, item 340, into cable drum and engage planet gears, item 320.
- 10) Lower brake housing assembly onto cable drum, while engaging spline of final sungear with primary planet hub, item 400. Line up mounting holes of bearing flange, item 530, with those in cable drum.
- 11) Rotate brake housing to line up access holes and fasten bearing flange using six capscrews, item 537, and lockwashers, item 541.
- 12) Install new, well-greased O-ring, item 735, into access plug, item 734. Install access plug into access hole inside brake housing.

REASSEMBLY OF BRAKE HOUSING ASSEMBLY:

Reassemble brake housing assembly as follows:

- 1) Install sprag clutch, item 723, into bore of brake hub, item 720. Position sprag clutch aligners, items 722 and 724, on either side of brake hub. Carefully slide motor drive shaft, item 730, into brake hub assembly and secure with circlip, item 727. Verify that circlips, items 719 and 731, are installed on motor drive shaft.
- 2) Carefully slide motor drive shaft, item 730, with brake hub assembly, into connecting shaft until it engages spline or primary sungear, item 440.

IMPORTANT: For proper brake function, verify that sprag clutch is installed correctly. When viewed from the motor end, the motor drive shaft of a clockwise hoisting winch must turn freely clockwise and lock in the counterclockwise direction.

- 3) Install brake spacer, item 712, into brake housing.



INCORRECT ASSEMBLY OF THE FRICTION PLATE AND DIVIDER PLATE STACK WILL REDUCE BRAKING CAPACITY AND ALLOW THE LOAD TO DROP, CAUSING PROPERTY DAMAGE, SEVERE INJURY OR DEATH. REASSEMBLE PER INSTRUCTIONS.

- 4) Starting and finishing with a divider plate, alternately install six divider plates, item 713, and five friction plates, item 715.
- 5) Liberally grease O-ring, item 751, and O-ring, item 753, and install on brake piston, item 750.
- 6) Slide brake piston, item 750, into brake housing, item 700, with holes for brake springs facing out of brake housing assembly. Install 14 brake springs, item 752, in brake piston using hole pattern shown:
- 7) Install 14 brake springs, item 752, in brake piston using hole pattern shown:

- 8) Liberally grease new O-rings, item 801, and install into recesses on motor adaptor, item 800. Install new, well-greased O-ring, item 707, on flange of motor adaptor.
- 9) Slide hydraulic motor assembly onto splined end of motor drive shaft, item 730, and lineup pressure transfer holes of brake housing and motor adaptor. Install 12 capscrews, item 537, and lockwashers, item 541. Tighten one turn at a time to evenly compress springs.

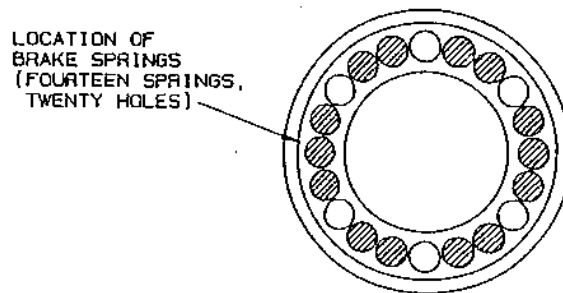

- 10) Install winch into common winch base with 26 capscrews, item 551 and flat washers, item 553.

REASSEMBLY OF HYDRAULIC MOTOR:

If the hydraulic motor was removed, the procedure for reassembly is the reverse of disassembly.

IMPORTANT: Before operating the winch, add lubricating oil up to the level of the end cover oil fill port. Refer to Lubricant Specifications section for oil volume required.

To ensure proper reassembly, run the winch in both directions without load.



DANGER

LIFTING A LOAD WITH A NEWLY SERVICED WINCH WILL ENABLE AN INSTALLATION OR SERVICE PROBLEM TO GO UNDETECTED AND ALLOW THE LOAD TO DROP CAUSING PROPERTY DAMAGE, SEVERE INJURY OR DEATH. TO ENSURE PROPER REINSTALLATION, REFER TO PROCEDURES AND TESTS DESCRIBED IN "INSTALLATION" AND "OPERATING INSTRUCTIONS".

RECOMMENDED MAINTENANCE

Winch gear train lubricating oil should be changed after the initial six months or 250 hours of operation, whichever comes first. Lubricating oil should then be changed every 12 months or 500 operating hours, whichever ever comes first.

Hydraulic system fluid should be changed at least once every 12 months.

For optimum performance over an extended period of time, the following preventive maintenance service should be done every 12 months or 500 operating hours (whichever ever comes first):

- 1) Disconnect all hydraulic hoses and remove the winch from its mounting.
- 2) Disassemble the winch as per instructions.
- 3) Discard and replace all O-rings and oil seals.
- 4) Clean all parts and inspect for wear and damage as per instructions. Replace worn or damaged parts as required.
- 5) Reassemble the winch as per instructions.
- 6) Follow INSTALLATION and OPERATING INSTRUCTIONS when returning winch to its mounting.

When ordering parts of the PULLMASTER Model M30D planetary winch always quote the complete model and serial number of the unit.

MODEL NO. **M30D-9-174-49-536**

PULLMASTER WINCH CORPORATION reserves the right to change specifications and the design of PULLMASTER planetary winches at any time without prior notice and without incurring any obligations

INSTALLATION INSTRUCTIONS



**FAILURE TO FOLLOW INSTALLATION INSTRUCTIONS WILL
RESULT IN PROPERTY DAMAGE, SEVERE INJURY OR DEATH.**

The initial installation or mounting of a PULLMASTER WINCH is critically important for proper operation and performance. The model M30D # 78183 winch with free fall is mounted to a machined common base. It is very important that the following instructions are observed when installing the PULLMASTER WINCH:

- 1) Make certain that the mounting platform is sufficiently strong to avoid deflection when a load is lifted.
- 2) If the winch has been removed from the common base for servicing, the correct bolts and washers must be used when reinstalling the winch. Tighten all twenty-six (26) capscrews per bolt torque chart.
- 3) Fill the winch with lubricating oil (see specifications).
- 4) Use recommended circuit components and hydraulic hoses.
- 5) The circulation return line of the winch should be plumbed in such a manner that the brake housing remains full of oil at all times. Connect the circulation return line directly to reservoir. Do not connect to a common return line.
- 6) Before operating the winch with a load, verify adequate circulation flow through the circulation return line as stated in TYPICAL HYDRAULIC CIRCUIT. Verify that pressure measured at the circulation supply port does not exceed the permissible pressure stated in SPECIFICATIONS. Winches equipped with the internal circulation option will supply circulation flow only when the winch is run in the lowering direction.

GENERAL:

Before attempting disassembly of the PULLMASTER Model M30 planetary winch with free fall, the following instructions for disassembly and reassembly should be read and understood:

It is suggested that all expendable parts, such as O-rings and oil seals, are not reused on reassembly. It is therefore important to have a seal kit (Part No. 23803) on hand before the unit is taken apart.

A clean working area is of prime importance, similar to conditions used for service work on any other hydraulic component.

All parts, as they are removed from the winch assembly, should be inspected for wear and damage. Worn or damaged parts must be replaced. Thoroughly clean parts before reassembly. Do not use solvent to clean the brake friction plates.

During reassembly, lubricate all O-rings and oil seals with grease before installation.

In the following service instructions, reference to parts is made by numbers and shown on the applicable group drawings.

DISASSEMBLY

For the majority of required service or repair work, disassembly is required only on the brake housing of the PULLMASTER Model M30D planetary winch with free fall. There are no special tools needed for the service or repair work and no adjustments or calibrations are necessary. Proceed with the disassembly as follows:

REMOVAL OF HYDRAULIC MOTOR:

If the analyzed service or repair work requires access to the interior of the brake housing, the hydraulic motor should not be removed. In this case, the hydraulic motor should be removed together with the motor adaptor as a complete assembly. If a problem has been analyzed to be in the hydraulic motor, proceed as follows:

- 1) Disconnect motor supply, drain and brake release hydraulic hoses.
- 2) Remove two capscrews, item 815 and flat washers, item 817.
- 3) Support and carefully withdraw motor, item 950, from motor adaptor spacer, item 802, and coupling, item 731.
CAUTION: The coupling may remain on the motor shaft. If so it should be replaced in motor drive shaft, item 730.
- 4) Remove and discard o-ring, item 819.

REMOVE HYDRAULIC MOTOR ASSEMBLY:

If removal of hydraulic motor is not necessary, proceed as follows:

- 1) Remove 12 hex head capscrews, item 537, with lockwashers, item 541, from motor adaptor, item 800. Since brake springs, item 752, apply pressure against inside motor adaptor, it is recommended that hex capscrews are unscrewed, one turn at a time, until spring pressure has been released. The complete motor assembly, including motor adaptor, can now be removed from brake housing assembly.
- 2) Remove and discard O-rings, item 801, and O-ring, item 707. (O-rings, item 801, seal pressure transfer hole for automatic brake release and are situated on flange of brake housing.)

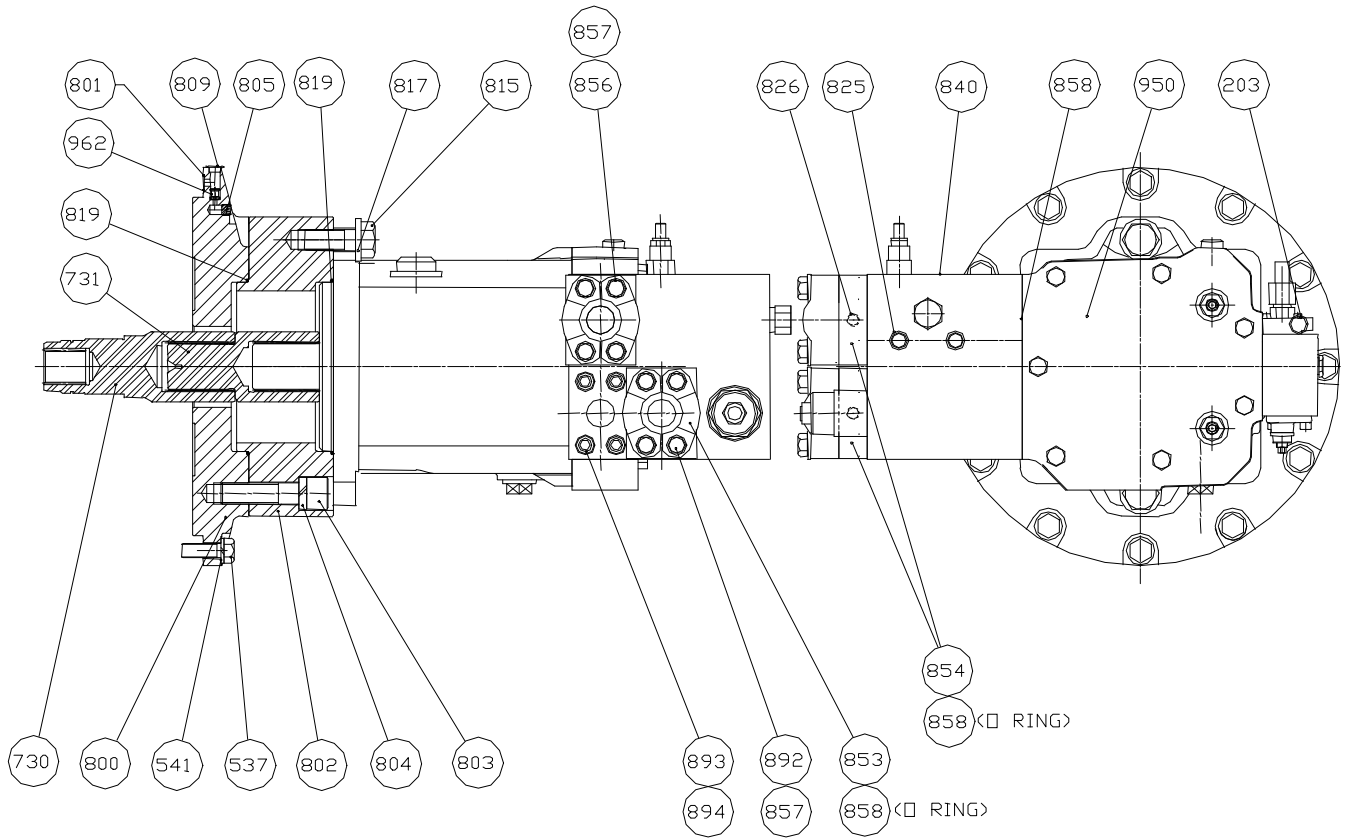

DISASSEMBLE BRAKE HOUSING ASSEMBLY:

- 1) After motor assembly has been removed, all parts of brake assembly are accessible. Remove 14 brake springs, item 752. Thoroughly examine springs for damage and measure overall length. Overall spring length should be 2.27 inches. If any spring measures less than 2.27 inches, replace all springs as a set.

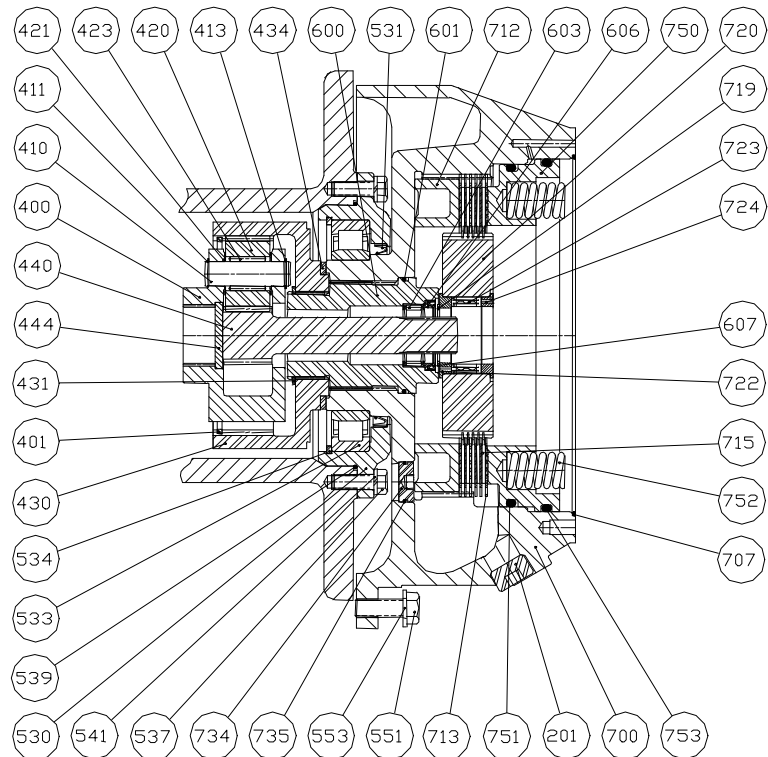

- 2) Remove coupling, item 731, and pull motor drive shaft, item 730, and complete brake hub assembly from brake housing.
- 3) Disassemble brake hub assembly by removing circlip, item 719, from motor drive shaft. Remove motor drive shaft from brake hub, item 720. Remove sprag clutch aligners, items 722 and 724, and sprag clutch, item 723, from brake hub.
- 4) Thoroughly inspect motor drive shaft, item 730, and brake hub, item 720, particularly surfaces where sprag clutch, item 723, engages. If any indentation of surface damage is detected, replace brake hub, sprag clutch and motor drive shaft as a set.



MINOR SURFACE DEFECTS WHERE THE SPRAG CLUTCH ENGAGES THE MOTOR DRIVE SHAFT AND BRAKE HUB, WILL RESULT IN BRAKE FAILURE AND ALLOW THE LOAD TO DROP, CAUSING PROPERTY DAMAGE, SEVERE INJURY OR DEATH. THOROUGHLY INSPECT THESE AREAS AND, IF NECESSARY, REPLACE MOTOR DRIVE SHAFT, SPRAG CLUTCH AND BRAKE HUB AS A SET.

- 5) Pull brake piston, item 750, out of brake housing using tow 5/8-11NC bolts screwed into two puller holes in piston. Discard O-rings, item 751 and item 753.
- 6) Thoroughly examine inner bores of brake housing and outer diameters of brake piston for scoring caused by hydraulic fluid contamination. Minor surface damage may be repaired by polishing with a fine emery cloth.



DAMAGED FRICTION OR DIVIDER PLATES WILL REDUCE BRAKING CAPACITY AND ALLOW THE LOAD TO DROP, CAUSING PROPERTY DAMAGE, SEVERE INJURY OR DEATH. SOLVENT MAY DAMAGE THE FRICTION PLATES. DO NOT USE SOLVENT TO CLEAN THE FRICTION PLATES. PERFORM THOROUGH INSPECTION AND, IF NECESSARY, REPLACE FRICTION AND DIVIDER PLATES AS A SET.

- 7) Remove five friction plates, item 715, together with six divider plates, item 713, and inspect for damage or wear. Plates should be flat and smooth. Plates should not show heat discoloration. Paper materials on friction plates should be intact and grooved. If any damage is detected, replace friction and divider plates as a set.
- 8) Remove brake spacer, item 712.
- 9) Oil seal, item 607, which seals brake housing from cable drum interior, can now be removed and discarded.

All parts have now been removed from the brake housing and there is not need for further disassembly, unless a failure has been analyzed in the remaining winch assembly.

DISASSEMBLY OF EMERGENCY FREE FALL ASSEMBLY:

If a failure occurs in free fall section of the winch, proceed as follows:

- 1) Remove drain plug, item 121, from end cover, item 240, and drain lubricating oil from free fall housing and end cover. The oil will drain quicker if the filler plug, item 201, is removed.
- 2) Remove 12 hex head capscrews, item 239, with lockwashers, item 529, and separate free fail clutch assembly from free fall housing, Item 200.

IMPORTANT: Internal gear, item 330, may come off the planet gears at this time. If this occurs, care must be taken to ensure the part does not slide out of ball bearing, item 103 and drop.

- 3) Remove internal gear, item 330.

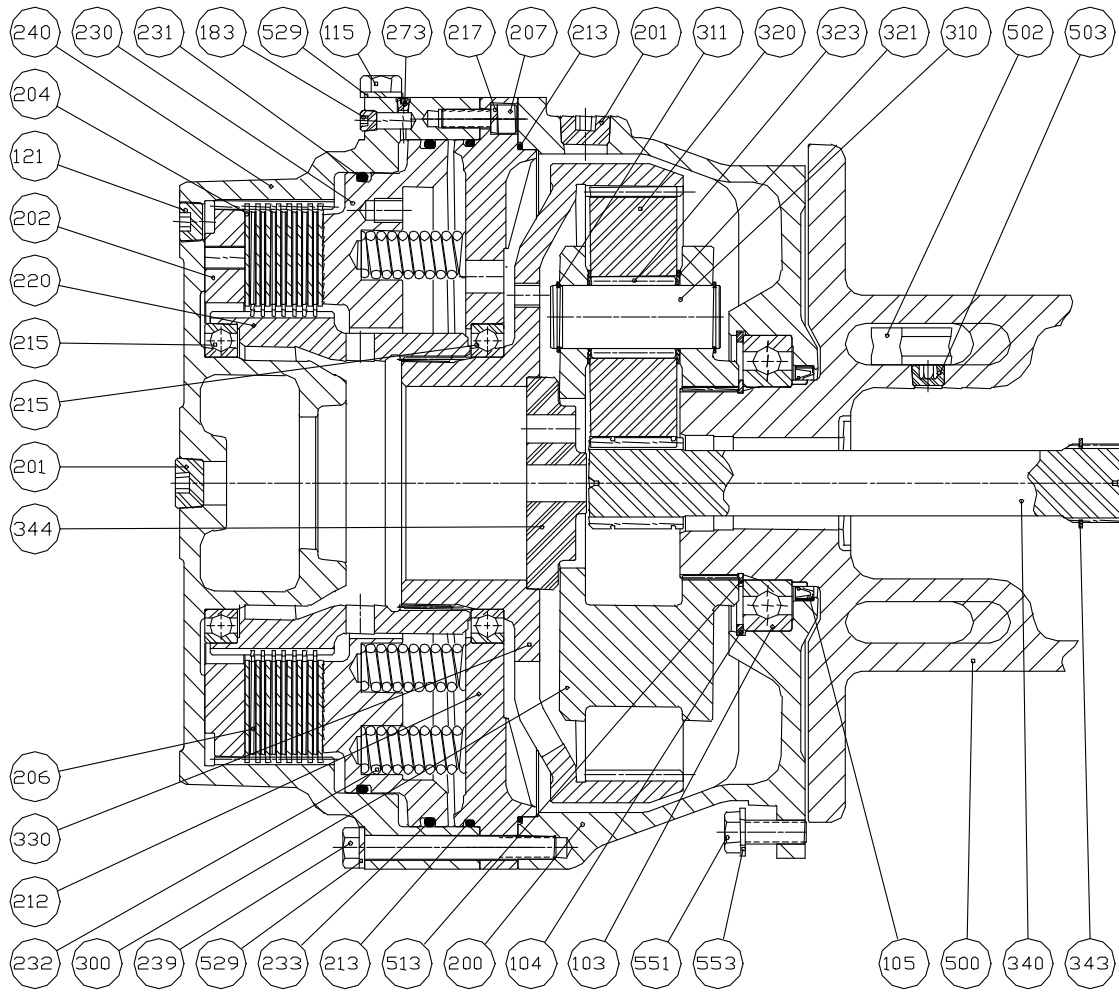

- 4) Inspect sungear stopper, item 344, for excessive wear. Replace if less than 1.54 inches thick and more than .05 inch wear on the surface in contact with planet hub.
 - 5) Pull planet assembly off of cable drum hub, item 500, and inspect for wear or damage. (Free fall end cover capscrews, item 239, can be screwed into two tapped pulling holes in planet hub to assist with removal of final planet hub assembly.)
 - 6) Inspect final planet gears, item 320, for damage or wear. If it is necessary to remove final planet gears, remove circlip, item 311, and press planet pin, item 310, out of planet hub, item 300. Inspect loose rollers, item 323, and two thrust washers, item 321, and replace if damaged.
 - 7) Pull final sungear, item 340, out of free fall assembly.
 - 8) Remove 12 socket head capscrews, item 207, along with lockwashers, item 217, from spring retainer, item 212.
- CAUTION:** Since 60 springs apply pressure behind spring retainer, socket head capscrews should be loosened one turn at a time, until spring pressure has been relieved.
- 9) Pull spring retainer, item 212, out of free fall end cover, item 240. Remove and discard O-ring, item 213, from spring retainer.
 - 10) Remove 60 springs, item 232, from clutch piston, item 230.
 - 11) Pull clutch piston, item 230, out of end cover, item 240. (Use two long 5/8-11NC capscrews screwed into piston to assist removal. Alternatively compressed air may be carefully applied to free fall release port to assist removal of clutch piston).
 - 12) Remove and discard O-rings, items 231 from clutch piston, and 233 from free fall end cover.

- 13) Check Clutch piston outside diameters and inside diameters of end cover for surface scratches due to contamination resulting from particles in the hydraulic fluid. If there is any evidence of surface damage, polish with fine emery cloth.
- 14) Pull clutch connecting shaft, item 220, out of end cover, along with bearing, item 215.



DAMAGED FRICTION OR DIVIDER PLATES WILL REDUCE BRAKING CAPACITY AND ALLOW THE LOAD TO DROP, CAUSING PROPERTY DAMAGE, SEVERE INJURY OR DEATH. SOLVENT MAY DAMAGE THE FRICTION PLATES. DO NOT USE SOLVENT TO CLEAN THE FRICTION PLATES. PERFORM THROUGH INSPECTION AND, IF NECESSARY, REPLACE FRICTION AND DIVIDER PLATES AS A SET.

- 15) Remove 7 friction plates, item 206, together with 8 divider plates, item 204, and inspect for damage or wear. Plates should be flat and smooth. Plates should not show heat discoloration. Paper material on friction plates should be intact and grooved. If any damage is detected, replace friction and divider plates as a set.
- 16) Remove clutch spacer, item 202.

DISASSEMBLY OF PRIMARY DRIVE AND CABLE DRUM ASSEMBLY:

For ease of working on remainder of unit, set winch upright on freefall housing.

- 1) Remove access plug, item 734, using a ½-13NC bolt (motor adaptor bolt, item 821, works nicely), from inside brake housing and discard O-ring, item 735.
- 2) Remove six hex capscrews, item 537, with lockwashers, item 541, from bearing flange, item 530, by rotating brake housing until access hole is over top.
- 3) Lift brake housing together with bearing flange and primary planet hub assembly from inside cable drum, item 500 and discard O-ring, item 539
- 4) Remove retaining ring, item 401, and remove primary planet hub assembly from inside internal gear, item 430.
- 5) Inspect primary planet gears, item 420, for damage or wear. If necessary to remove primary planet gears, remove circlip, item 411, and press planet pin, item 410, out of planet hub, item 400. Inspect loose rollers, item 423, and two thrust washers, item 421, and replace if damaged.
- 6) Remove primary sungear, item 440, from center of connecting shaft, item 600.
- 7) Remove circlip, item 431, and internal gear, item 430, from connecting shaft spline.
- 8) Remove spacer, item 434.
- 9) Pull connecting shaft, item 600, out of brake housing. Discard O-ring, item 601.
- 10) Remove and discard oil seal, item 607, from inside of connecting shaft.
- 11) Remove needle bearing, item 603. Inspect and replace if damaged.
- 12) Separate bearing flange, item 530, and brake housing, item 700, using a standard bearing puller or insert two heel bars in slot between bearing flange and brake housing. Pry brake housing out of cylindrical bearing, item 533.
- 13) Remove internal retaining ring, item 534, and remove the outer race and caged roller assembly of cylindrical roller bearing, item 533
- 14) Remove and discard oil seal, item 531.
- 15) Remove the separate inner race of cylindrical roller bearing, item 533, from brake housing, item 700.

- 16) To separate free fall housing, item 200, and cable drum, item 500, first remove external circlip, item 513, off end of cable drum, then insert two heel bars in slot between final drive housing and cable drum and pry cable drum out of ball bearing, item 103.
- 17) Remove internal retaining ring, item 104, to remove ball bearing, item 103. Remove and discard oil seal, item 105 (this seal separates interior of free fall housing and interior of cable drum).

The PULLMASTER Model M30D with free fall has now been completely disassembled.

REASSEMBLY

Thoroughly clean all parts. Use only new, well-greased O-rings and oil seals. Unless otherwise specified, torque fasteners per BOLT TORQUE CHART in Appendix F. If the entire winch was disassembled, start by reassembling the free fall end first.

REASSEMBLY OF FREE FALL ASSEMBLY:

- 1) If free fall housing was removed, press in new oil seal, item 105, and bearing, item 103, if removed. Re-install retaining ring, item 104.
- 2) Press free fall housing, item 200, onto splined end of cable drum, and install cliclip, item 513.
- 3) Set end cover, item 240, with opening facing up.
- 4) Install clutch connecting shaft, item 220, together with bearing, item 215, into end cover.
- 5) Set clutch spacer, item 202, into end cover, and place a divider plate, item 204, against it, lining up teeth with those inside of end cover.



**INCORRECT ASSEMBLY OF THE FRICTION PLATE AND DIVIDER PLATE STACK WILL
REDUCE BRAKING CAPACITY AND ALLOW THE LOAD TO DROP, CAUSING
PROPERTY DAMAGE, SEVERE INJURY OR DEATH. REASSEMBLE PER INSTRUCTIONS.**

- 6) Place brake plate, item 206, against divider plate, lining up teeth onto teeth of clutch connecting shaft, item 220. Alternate remaining divider and brake plates, finishing stack with a divider plate.
- 7) Install new, well greased O-rings, item 231 and item 233, onto clutch piston, item 230.
- 8) Carefully press clutch piston, item 230, into end cover, item 240. If a hoist is available, piston can be supported using two 5/8-11NC eyebolts.
- 9) Place 60 springs, item 232, into holes in clutch piston.
- 10) Install two new, well-greased O-rings, item 213, into grooves on flanges of spring retainer, item 212.
- 11) Fasten spring retainer to end cover using 12 socket head capscrews, item 207, along with 12 high collar lockwashers, item 217. Fasten capscrews, one turn at a time, to compress 60 springs.
- 12) Reassemble final planet hub assembly. Use grease to temporarily hold 24 loose rollers, item 323, in bore of planet gear, item 320. Position bearing spacers, item 322, and thrust washers, item 321, on either side of planet gear. Press planet pin, item 310, into final planet hub, item 300, and retain with circlip, item 311.
- 13) Insert final planet hub assembly into free fall housing, item 200. Ensure that final planet hub spline is fully engaged with cable drum, item 500.

- 14) Install internal gear, item 330, with sungear stopper, item 344, over top of planet gears, item 320.
- 15) Install end cover, item 240, and spring retainer assembly, into free fall housing and secure with 12 capscrews, item 239, and lockwashers, item 237.

REASSEMBLY OF PRIMARY DRIVE:

Turn winch over, resting on end housing with cable drum opening facing upward. Reassemble primary drive as follows:

NOTE: Care must be taken when handling the assembly at this stage, avoid separation of the bearing flange sub-assembly and brake housing.

- 1) Press new, well greased oil seal, item 531, into bearing flange, item 530. Press outer race complete with caged roller assembly of cylindrical roller bearing, item 533, into bearing flange and secure with retaining ring, item 534.
- 2) Install bearing flange assembly onto brake housing and then press the inner race of cylindrical roller bearing, item 533 onto brake housing, item 700, and install new, well-greased O-ring, item 539.
- 3) Press needle bearing, item 603, into connecting shaft, item 600.
- 4) Install new, well-greased oil seal, item 607, into connecting shaft.
- 5) Install new, well-greased O-ring, item 601, onto connecting shaft, item 600, and insert connecting shaft into brake housing, item 700.
- 6) Slide internal gear, item 430, along with spacer, item 434, onto end of connecting shaft and fasten in place with circlip, item 431.
- 7) Reassemble primary planet hub assembly. Use grease to temporarily hold 15 loose rollers, item 423, in bore of planet gear, item 420. Verify placement of sungear stopper, item 444. Position thrust washers, item 421, on either side of planet gear and press planet pin, item 410, into primary planet hub, item 400. Retain with circlip, item 411.
- 8) Insert primary sungear, item 440, between planet gears and insert sungear shaft into connecting shaft, engaging planet gears with internal gear. Fasten with retaining ring, item 401.
- 9) Insert final sungear, item 340, into cable drum and engage planet gears, item 320.
- 10) Lower brake housing assembly onto cable drum, while engaging spline of final sungear with primary planet hub, item 400. Line up mounting holes of bearing flange, item 530, with those in cable drum.
- 11) Rotate brake housing to line up access holes and fasten bearing flange using six capscrews, item 537, and lockwashers, item 541.
- 12) Install new, well-greased O-ring, item 735, into access plug, item 734. Install access plug into access hole inside brake housing.

REASSEMBLY OF BRAKE HOUSING ASSEMBLY:

Reassemble brake housing assembly as follows:

- 1) Install sprag clutch, item 723, into bore of brake hub, item 720. Position sprag clutch aligners, items 722 and 724, on either side of brake hub. Carefully slide motor drive shaft, item 730, into brake hub assembly and secure with circlip, item 727. Verify that circlips, items 719 and 731, are installed on motor drive shaft.
- 2) Carefully slide motor drive shaft, item 730, with brake hub assembly, into connecting shaft until it engages spline of primary sungear, item 440.

IMPORTANT: For proper brake function, verify that sprag clutch is installed correctly. When viewed from the motor end, the motor drive shaft of a clockwise hoisting winch must turn freely clockwise and lock in the counterclockwise direction.

- 3) Install brake spacer, item 712, into brake housing.



DANGER

INCORRECT ASSEMBLY OF THE FRICTION PLATE AND DIVIDER PLATE STACK WILL REDUCE BRAKING CAPACITY AND ALLOW THE LOAD TO DROP, CAUSING PROPERTY DAMAGE, SEVERE INJURY OR DEATH. REASSEMBLE PER INSTRUCTIONS.

- 4) Starting and finishing with a divider plate, alternately install six divider plates, item 713, and five friction plates, item 715.
- 5) Liberally grease O-ring, item 751, and O-ring, item 753, and install on brake piston, item 750.
- 6) Slide brake piston, item 750, into brake housing, item 700, with holes for brake springs facing out of brake housing assembly.
- 7) Install 14 brake springs, item 752, in brake piston using hole pattern shown:
- 8) Liberally grease new O-rings, item 801, and install into recesses on motor adaptor, item 800. Install new, well-greased O-ring, item 707, on flange of motor adaptor.

LOCATION OF
BRAKE SPRINGS
(FOURTEEN SPRINGS,
TWENTY HOLES)

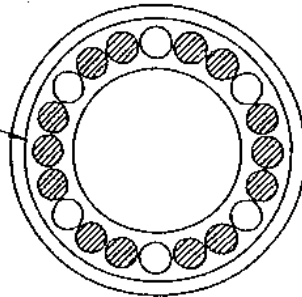

- 9) Install coupling, item 731, into motor drive shaft, item 730.
- 10) Slide hydraulic motor assembly onto splined end of coupling, item 731, and lineup pressure transfer holes of brake housing and motor adaptor. Install 12 capscrews, item 537, and lockwashers, item 541. Tighten one turn at a time to evenly compress springs.
- 11) Install winch into common winch base with 26 capscrews, item 551 and flat washers, item 553.

REASSEMBLY OF HYDRAULIC MOTOR:

If the hydraulic motor was removed, the procedure for reassembly is the reverse of disassembly.

IMPORTANT: Before operating the winch, add lubricating oil up to the level of the end cover oil fill port. Refer to Lubricant Specifications section for oil volume required.

To ensure proper reassembly, run the winch in both directions without load.



DANGER

LIFTING A LOAD WITH A NEWLY SERVICED WINCH WILL ENABLE AN INSTALLATION OR SERVICE PROBLEM TO GO UNDETECTED AND ALLOW THE LOAD TO DROP CAUSING PROPERTY DAMAGE, SEVERE INJURY OR DEATH. TO ENSURE PROPER REINSTALLATION, REFER TO PROCEDURES AND TESTS DESCRIBED IN "INSTALLATION" AND "OPERATING INSTRUCTIONS".

RECOMMENDED MAINTENANCE

Winch gear train lubricating oil should be changed after the initial six months or 250 hours of operation, whichever comes first. Lubricating oil should then be changed every 12 months or 500 operating hours, whichever ever comes first.

Hydraulic system fluid should be changed at least once every 12 months.

For optimum performance over an extended period of time, the following preventive maintenance service should be done every 12 months or 500 operating hours (whichever ever comes first):

- 1) Disconnect all hydraulic hoses and remove the winch from its mounting.
- 2) Disassemble the winch as per instructions.
- 3) Discard and replace all O-rings and oil seals.
- 4) Clean all parts and inspect for wear and damage as per instructions. Replace worn or damaged parts as required.
- 5) Reassemble the winch as per instructions.
- 6) Follow INSTALLATION and OPERATING INSTRUCTIONS when returning winch to its mounting.

When ordering parts of the PULLMASTER Model M30 planetary winch with free fall, always quote the complete model and serial number of the unit.

MODEL NO. **M30D-9-173-49D-522**

PULLMASTER WINCH CORPORATION reserves the right to change specifications and the design of PULLMASTER planetary winches at any time without prior notice and without incurring any obligations

Boom Winch Troubleshooting – M30D-9-174-49-536

GENERAL:

In most cases, when the hydraulic winch does not perform satisfactorily, the cause of malfunction is found somewhere in the hydraulic circuit. Before the winch is removed from its mounting and disassembled, all of the hydraulic circuit components should be checked for proper function.

IMPORTANT:

The hydraulic oil volume relates to the line speed or rpm of the winch.

Therefore, if the winch does not produce the specified maximum rated line speed or drum rpm, a loss of hydraulic flow somewhere in the hydraulic circuit system can be analysed. If this condition exists, install a flow meter into the hydraulic circuit to check the volume supplied to the pressure port of the hydraulic winch motor when the winch control is completely opened. The flow meter should indicate the maximum operating volume. If this test indicates a loss of hydraulic flow, check the hydraulic pump, the relief valve and the control valve. If the pump is driven by V-belts, check for belt slippage.

The hydraulic pressure relates to the line pull or lifting capacity of the winch.

If the winch will not lift the specified maximum line pull, install a pressure gauge into the pressure line leading to the hoisting port on the hydraulic winch motor. Stall the winch to prevent rotation of the drum and then open the control valve. Check the hydraulic pressure reading of the installed pressure gauge. If the pressure reads below the specified maximum operating pressure, look for trouble in the hydraulic pump, the relief valve and the control valve. If the pump is driven by V-belts, check for belt slippage. When checking oil pressure and volume in the hydraulic circuit, make certain that the hydraulic reservoir is filled to the top level and the hydraulic pump is running at maximum operating rpm.

Only if the hydraulic system has been checked and found to be in order, use the following indications for probable causes of failure in the winch:

FAILURE	PROBABLE CAUSE
Winch will not produce line pull at maximum pressure as listed in SPECIFICATIONS.	<ul style="list-style-type: none"> a) Winch is mounted to an uneven surface. (See INSTALLATION INSTRUCTIONS). b) Cable sheaves or block purchase operated with the winch are not turning freely. c) Damage or wear in the hydraulic motor. d) Excessive back pressure in the hydraulic system. e) Relief valve may be set too low. (See SPECIFICATIONS for maximum operating pressure.)
Winch will not produce line speed at maximum volume as listed in SPECIFICATIONS.	<ul style="list-style-type: none"> a) Winch is mounted to an uneven surface. (See INSTALLATION INSTRUCTIONS). b) Cable sheaves or block purchase operated with the winch are not turning freely. c) Damage or wear in the hydraulic motor. d) Excessive back pressure in the hydraulic circuit.
Winch will not reverse.	<ul style="list-style-type: none"> a) Leakage out of the brake piston prevents the brake from being released against the brake springs. This is caused by damaged O-ring seals on the brake piston. b) The O-ring seals, on the brake release channel between the motor adaptor and the brake housing is damaged. If this failure occurs there will be substantial leakage from between the motor adaptor and brake housing. c) Insufficient hydraulic pressure. (See SPECIFICATIONS for minimum operating pressure). d) Winch is mounted to an uneven surface. (See INSTALLATION INSTRUCTIONS). e) Hydraulic pressure is not reaching the brake piston (plugged brake release orifice in the brake housing).

FAILURE	PROBABLE CAUSE
Brake will not hold.	<ul style="list-style-type: none"> a) Brake plates or divider plates have been damaged by contamination in the hydraulic fluid, or lack of circulation flow in the brake housing. b) Brake piston is seized in the brake housing because of contamination in the hydraulic fluid. c) Excessive back pressure in the return line causes the brake to be released. d) Control valve has incorrect spool, which traps hydraulic pressure in the brake piston when the control valve handle is returned to neutral position. For proper function of the automatic brake, both pressure ports of the winch must be open to the reservoir in neutral position of the control valve. e) Wire rope is fastened to the incorrect cable anchor slot. f) Sprag clutch is damaged or surfaces where sprag clutch engages on motor drive shaft or brake hub are worn or indented. g) Winch supplied with external brake release option is not plumbed per TYPICAL HYDRAULIC CIRCUIT. Failure to vent external brake release port to reservoir may trap pressure and cause winch brake to slip.
Brake vibrates when powering down a load.	<ul style="list-style-type: none"> a) Pump is too slow. Pump rpm must be maintained at normal operating speed when a load is lowered. b) Brake is running too hot. This is caused by insufficient circulation flow. To check the circulation, observe the flow of oil from the circulation return line of the winch (see Typical Hydraulic Circuit) when the winch is reversed). c) Control valve has poor 'metering' characteristics. d) Damaged brake plates or divider plates. e) The over-running clutch, which connects the motor with the brake assembly, is damaged. f) Air mixed with hydraulic oil (foamy oil).
Oil leaks.	<ul style="list-style-type: none"> a) Oil leaks from the motor flange and the motor adaptor are caused by a damaged O-ring seals. b) Oil leaks occurring between cable drum flanges and housings are caused by excessive pressure in free fall housing or brake housing. Excessive pressure will damage the oil seal which separates the brake housing from the cable drum interior. c) If the breather relief on the end cover leaks, the seal between the drum interior and the brake housing is damaged and must be replaced. This condition is caused by excessive pressure in the brake housing of the winch, operation with the incorrect hydraulic fluid during cold weather, or a restriction in the circulation return line leading back to tank.

Hook Winch Troubleshooting – M30D-9-173-49D-522

GENERAL:

In most cases, when the hydraulic winch does not perform satisfactorily, the cause of malfunction is found somewhere in the hydraulic circuit. Before the winch is removed from its mounting and disassembled, all of the hydraulic circuit components should be checked for proper function.

IMPORTANT:

The hydraulic oil volume relates to the line speed or rpm of the winch.

Therefore, if the winch does not produce the specified maximum rated line speed or drum rpm, a loss of hydraulic flow somewhere in the hydraulic circuit system can be analysed. If this condition exists, install a flow meter into the hydraulic circuit to check the volume supplied to the pressure port of the hydraulic winch motor when the winch control is completely opened. The flow meter should indicate the maximum operating volume. If this test indicates a loss of hydraulic flow, check the hydraulic pump, the relief valve and the control valve. If the pump is driven by V-belts, check for belt slippage.

The hydraulic pressure relates to the line pull or lifting capacity of the winch.

If the winch will not lift the specified maximum line pull, install a pressure gauge into the pressure line leading to the hoisting port on the hydraulic winch motor. Stall the winch to prevent rotation of the drum and then open the control valve. Check the hydraulic pressure reading of the installed pressure gauge. If the pressure reads below the specified maximum operating pressure, look for trouble in the hydraulic pump, the relief valve and the control valve. If the pump is driven by V-belts, check for belt slippage. When checking oil pressure and volume in the hydraulic circuit, make certain that the hydraulic reservoir is filled to the top level and the hydraulic pump is running at maximum operating rpm.

Only if the hydraulic system has been checked and found to be in order, use the following indications for probable causes of failure in the winch:

FAILURE	PROBABLE CAUSE
Winch will not produce line pull at maximum pressure as listed in SPECIFICATIONS.	<ul style="list-style-type: none"> a) Winch is mounted to an uneven surface. (See INSTALLATION INSTRUCTIONS). b) Cable sheaves or block purchase operated with the winch are not turning freely. c) Damage or wear in the hydraulic motor. d) Excessive back pressure in the hydraulic system. e) Relief valve may be set too low. (See SPECIFICATIONS for maximum operating pressure.) f) Clutch release valve may be in release position.
Winch will not produce line speed at maximum volume as listed in SPECIFICATIONS.	<ul style="list-style-type: none"> a) Winch is mounted to an uneven surface. (See INSTALLATION INSTRUCTIONS). b) Cable sheaves or block purchase operated with the winch are not turning freely. c) Damage or wear in the hydraulic motor. d) Excessive back pressure in the hydraulic circuit.
Winch will not reverse.	<ul style="list-style-type: none"> a) Leakage out of the brake piston prevents the brake from being released against the brake springs. This is caused by damaged O-ring seals on the brake piston. b) The O-ring seals, on the brake release channel between the motor adaptor and the brake housing is damaged. If this failure occurs there will be substantial leakage from between the motor adaptor and brake housing. c) Insufficient hydraulic pressure. (See SPECIFICATIONS for minimum operating pressure). d) Winch is mounted to an uneven surface. (See INSTALLATION INSTRUCTIONS). e) Hydraulic pressure is not reaching the brake piston (plugged brake release orifice in the brake housing).

FAILURE	PROBABLE CAUSE
Brake will not hold.	<ul style="list-style-type: none"> a) Brake plates or divider plates have been damaged by contamination in the hydraulic fluid, or lack of circulation flow in the brake housing. b) Brake piston is seized in the brake housing because of contamination in the hydraulic fluid. c) Excessive back pressure in the return line causes the brake to be released. d) Control valve has incorrect spool, which traps hydraulic pressure in the brake piston when the control valve handle is returned to neutral position. For proper function of the automatic brake, both pressure ports of the winch must be open to the reservoir in neutral position of the control valve. e) Hydraulic pressure is trapped in the clutch piston, preventing total engagement. This is caused by using an incorrect control valve. The free fall control valve must leave the free fall release port open to reservoir when not activated. f) Wire rope is fastened to the incorrect cable anchor slot. g) Sprag clutch is damaged or surfaces where sprag clutch engages on motor drive shaft or brake hub are worn or indented. h) Winch supplied with external brake release option is not plumbed per TYPICAL HYDRAULIC CIRCUIT. Failure to vent external brake release port to reservoir may trap pressure and cause winch brake to slip.
Brake vibrates when powering down a load.	<ul style="list-style-type: none"> a) Pump does not supply sufficient flow. Pump rpm must be maintained at normal operating speed when a load is lowered. b) Brake is running too hot. This is caused by insufficient circulation flow. To check the circulation, observe the flow of oil from the circulation return line of the winch (approx. 5 (US) gpm - 19 l/min when the winch is reversed). c) Control valve for the winch operation has poor 'metering' characteristics. d) Damaged brake plates or divider plates. e) The over-running clutch, which connects the motor with the brake assembly, is damaged. f) Air mixed with hydraulic oil (foamy oil).
Free fall clutch cannot be disengaged.	<ul style="list-style-type: none"> a) Insufficient pressure or flow supplied to free fall port (refer to TYPICAL HYDRAULIC CIRCUIT). b) O-ring seals in clutch piston are damaged. c) Insufficient load on the wire rope. A minimum of 500Ib (227 kg) on a standard -1 drum is required to drop a load in free fall.
Free fall cannot be controlled.	<ul style="list-style-type: none"> a) Emergency free fall is non-controllable. b) Piping circuit or control valve is incorrect. Check hydraulic circuit. c) Control valve used has poor metering characteristics. The control valve should have a flow capacity of 3 - 6 gpm maximum. If a large volume control valve is used, it may not provide good metering of the hydraulic oil, resulting in poor speed control. d) Hydraulic metering pump, installed in the end housing, is damaged.

FAILURE	PROBABLE CAUSE
<p>Oil leaks.</p>	<ul style="list-style-type: none"> a) Oil leaks from the motor flange are caused by a damaged O-ring seal on the motor flange. b) Oil leaks occurring between cable drum flanges and housings are caused by excessive pressure in free fall housing or brake housing. If pressure in free fall end exceeds 10 psi (.7 bar) check for restrictions in free fall circulation return line. If pressure in brake housing exceeds 30 psi (2 bar) check for damage to oil seal, item 607, and restrictions in brake circulation return line. Both circulation return lines must go directly back to reservoir. c) Oil leaking out of the free fall housing on either side of the spring retainer is caused by a damaged o-ring seal, item 213.

Bolt Torque Chart for Pullmaster Winches

BOLT DIAMETER Inches	TORQUE Lb-ft	TORQUE Nm
1/4	9	12
5/16	18	24
3/8	32	43
7/16	50	68
1/2	75	102
9/16	110	149
5/8	150	203
3/4	265	359
7/8	420	569
1	640	868
1 1/8	800	1085
1 1/4	1000	1356
1 3/8	1200	1627
1 1/2	1500	2034

NOTE: Unless otherwise specified, torque bolts per above chart.